



DLC TECHNICAL REQUIREMENTS
FOR LED LIGHTING

SSL V6.0 & LUNA V2.0

FINAL POLICY
RELEASED NOVEMBER 3, 2025



About this Document

This version of the DLC Technical Requirements for LED Lighting supersedes the V5.1 Technical Requirements, all standalone SSL Technical Requirement policies, and the LUNA V1.0 Technical Requirements.

How to Navigate this Document

To make it easier for readers to navigate and quickly find the information they need, the Technical Requirements document has been reorganized into clearly defined parts. Each part groups related content together and provides a logical flow from general information to detailed requirements and supporting guidance.

Part I – General Information

Provides background, purpose, and context for the requirements document, including definitions and scope.

Part II – DLC Standard Requirements

Outlines the baseline requirements applicable to all products seeking DLC qualification.

Part III – Requirements for DLC Premium

Details the enhanced performance requirements necessary for products seeking DLC Premium qualification.

Part IV – Requirements for LUNA V2.0

Specifies the requirements unique to the LUNA program.

Part V – Requirements for Specialized Product Types

Provides product-type-specific requirements that supplement Parts II–IV.

Part VI – Minimum Testing and Reporting Requirements and Additional Guidance for Demonstrating Compliance to Parts II – V

Defines the testing and reporting protocols, as well as additional guidance for demonstrating compliance with Parts II through V.

Part VII – Appendices

Contains supplemental information that is helpful for understanding requirements throughout this document but have been located here due to the length of information included.

Part VIII – Policy Clarifications and Updates

Summarizes policy interpretations, clarifications, and updates to ensure consistency in program implementation.

Navigating Internal Links

The *internal links* (blue italics) in this document are designed to help you quickly find what you need. In Adobe Reader, you can go back to where you were after clicking a link by pressing Alt + Left Arrow (PC) or Command + Left Arrow (Mac) on your keyboard.



Table of Contents

Part I: General Information	1
1 Introduction	2
1.1 Goals of the Technical Requirements	3
1.2 Definitions	3
1.3 Abbreviations	5
2 Eligibility	7
2.1 Introduction	7
2.2 Eligibility Guidance for the "Specialty" Primary Use Designation.....	12
2.3 Eligibility for Hazardous Environment Products	12
2.4 Updates and Additions to Eligible PUDs	12
Part II: DLC Standard Requirements	14
3 Efficacy	15
3.1 Introduction	15
3.2 Efficacy Requirements	15
4 Quality of Light	18
4.1 Introduction	18
4.2 Spectral Quality Requirements	18
4.3 Light Output and Distribution Requirements	21
4.4 Interactions With Other DLC Policies: Field Adjustable Light Distribution (FALD) and Field Adjustable Light Output (FALO)	31
5 Controllability	32
5.1 Introduction	32
5.2 Controls Categories.....	32
5.3 Driver and Integral Controller or Sensor Types	33
5.4 Controls Ready (Controls Category 1).....	34
5.5 Controls Options Tables	36
5.6 Dimming Requirements	39
5.7 Special Controllability Considerations for Dimmable Lamps.....	40
5.8 Integral Controls	42
5.9 Control Communication.....	45



5.10 Documentation Requirements.....	49
6 Additional Documentation Requirements.....	50
6.1 Introduction	50
6.2 Required Product Images.....	50
6.3 Product Specification Sheets	51
7 Lumen Maintenance.....	53
7.1 Introduction	53
7.2 Lumen Maintenance	53
8 Power Quality	54
8.1 Introduction	54
8.2 Power Factor and Total Harmonic Distortion (THD).....	54
9 Safety	55
9.1 Introduction	55
9.2 Original Equipment Manufacturer (OEM) Safety Certification Testing and Reporting Requirements	55
10 Warranty	56
10.1 Introduction	56
10.2 Warranty Requirements	56
11 Sustainability	57
11.1 Introduction	57
11.2 Sustainability Reporting Options	57
12 Efficacy Allowances	60
12.1 Introduction	60
12.2 Efficacy Allowances.....	60
13 Tolerances.....	63
13.1 Introduction	63
13.2 Tolerances.....	63
Part III: Requirements for DLC Premium.....	65
14 DLC Premium	66
14.1 Introduction	66
14.2 Premium Eligibility	66



14.3 Driver Lifetime	67
14.4 Premium Requirements	68
Part IV: Requirements for LUNA V2.0.....	72
15 LUNA V2.0 Technical Requirements	73
15.1 Introduction	73
15.2 LUNA Eligibility and Requirements	73
15.3 LUNA Light Distribution Requirements.....	75
15.4 LUNA Spectral Quality Requirements	79
15.5 LUNA Controllability Requirements	82
15.6 LUNA Turtle Lighting PUD Requirements	82
15.7 LUNA Testing and Reporting Requirements	82
15.8 Efficacy Allowances for LUNA Qualified Products	83
Part V: Requirements for Specialized Product Types	86
16 Field Adjustable Products	87
16.1 Introduction	87
16.2 Field Adjustable Color Temperature (FACT)	88
16.3 Field Adjustable Light Output (FALO).....	89
16.4 Field Adjustable Light Distribution (FALD)	91
16.5 Supporting Documentation	94
16.6 Listing on the QPL	94
16.7 Additional Notes	95
17 Color-Tunable Products	96
17.1 Introduction	96
17.2 Definitions of Color-Tunable Products.....	96
17.3 CCT-Tunable and Full Color-Tunable Eligibility	97
17.4 Warm-Dimming Eligibility	98
17.5 Supporting Documentation for Color-Tunable Products.....	98
17.6 Listing on the QPL	99
18 Amber Products	100
18.1 Introduction	100
18.2 Specifications for Amber LED Luminaires, Retrofit Kits, and Lamps.....	100



18.3 Efficacy Requirements for Amber LED products.....	101
18.4 Spectral Quality Requirements for Amber LED Products	101
19 Solar Powered Outdoor Luminaires.....	104
19.1 Introduction	104
19.2 Special Considerations for Solar Powered Outdoor Luminaires.....	104
20 Direct Current (DC) and Power Over Ethernet (POE)	108
20.1 Introduction	108
20.2 Testing Methods and Requirements.....	108
20.3 Listing on the QPL	110
21 Modular Products with External Power Supplies	112
21.1 Introduction	112
21.2 Modular Products With External Power Supplies.....	112
Part VI: Minimum Testing and Reporting Requirements and Additional Guidance for Demonstrating Compliance to Parts II Through V.....	113
22 Lamps and Reference Housing Requirements	114
22.1 Introduction	114
22.2 Pre-approved Equivalent Luminaires and Ballasts.....	114
22.3 Luminaire Level Tests.....	115
22.4 Mogul Screw Base (E39, E40) HID Replacement Lamps Tested in Reference Housings.....	115
22.5 Four Pin-Base Replacement Lamps for CFLs	116
22.6 Other Categories Tested in “Reference” Housings	118
22.7 Testing and Reporting Requirements for Linear and 2G11-Base Replacement Lamps; and Mogul and Medium Screw-Base Replacement Lamps.....	118
23 Retrofit Kits Testing.....	121
23.1 Introduction	121
23.2 Testing and Reporting Requirements for Retrofit Kits.....	121
23.3 Special Considerations for Unique Retrofit Kit Scenarios.....	123
24 Minimum Testing Requirements.....	125
24.1 Introduction	125
24.2 Demonstrating Compliance With SSL V6.0 and LUNA V2.0.....	125
25 Testing Requirements for Long and Complex Products	144
25.1 Introduction	144



25.2 Alternative Testing Pathway	144
25.3 Alternative Testing for Linear Style Products	144
25.4 Alternative Testing for Luminaires With Direct and Indirect Components	145
25.5 Alternative Testing for Eight-Foot T8 Replacement Lamps	147
26 Testing and Reporting Requirements for Alternate LEDs and Drivers.....	149
26.1 Introduction	149
26.2 Testing and Reporting Requirements for Alternate LEDs and Drivers.....	149
27 Additional Requirements for LM-79, LM-80, and TM-21 Test Reports.....	150
27.1 Introduction	150
27.2 ANSI/IES LM-79 (-19 and -24 Versions).....	150
27.3 IES TM-21-11, ANSI/IES TM-21-19, ANSI/IES TM-21-21, and the ANSI/IES TM-21 Calculator	155
27.4 IES LM-80 Versions.....	156
Part VII: Appendices.....	157
28 Appendix A: Primary Use Designation Definitions.....	158
28.1 Outdoor.....	158
28.2 Indoor.....	165
28.3 Outdoor Retrofit Kits.....	170
28.4 Indoor Retrofit Kit	172
28.5 Solar Powered Outdoor Luminaires.....	174
28.6 Linear Replacement Lamps.....	174
28.7 Mogul Screw-Base (E39/E40) Replacements for HID Lamps	178
28.8 Medium Screw-Base (E26, E27) Replacement for HID Lamps	181
28.9 Four Pin-Base Replacement Lamp for CFLs.....	181
29 Appendix B: Referenced Standards	183
Part VIII: Policy Clarifications and Updates.....	188
30 Policy Clarifications and Updates	189



Table List

Table 1: Categories, General Applications, and Primary Use Designations (PUD)	8
Table 2: DLC Standard Efficacy Requirements for Luminaires and Retrofit Kits Within Standardized CCT Quadrangles (1800 K to 6500 K as Applicable*)	15
Table 3: Standard Efficacy Requirements for Lamps Within Standardized CCT Quadrangles (1800 K to 6500 K as Applicable*) [In-Luminaire and Bare-Lamp].....	17
Table 4: Testing and Reporting Requirements for Spectral Quality (DLC Standard)	18
Table 5: Light Output Requirements by General Application for Outdoor Luminaires, Retrofit Kits and Lamps	21
Table 6: Light Output Requirements by Primary Use Designation	22
Table 7: Testing and Reporting Requirements for Light Distribution (DLC Standard).....	25
Table 8: Primary Use Designation Technical Requirements: Light Distribution	26
Table 9: Controls Categories	32
Table 10: Controls Ready Receptacle Types	35
Table 11: Controls Options Table Details.....	36
Table 12: Standard Dimming Requirements	40
Table 13: V6.0 Integral Sensor Functions.....	42
Table 14: V6.0 Integral Sensor Technologies	44
Table 15: Driver and Integral Controller or Sensor Type Descriptions	46
Table 16: Lumen Maintenance Requirements for DLC Standard	53
Table 17: Optionally Reported Sustainability Fields	58
Table 18: Efficacy Allowances	60
Table 19: Tolerances	64
Table 20: DLC Premium Efficacy Requirements.....	68
Table 21: DLC Premium Testing and Reporting Requirements.....	70
Table 22: PUDs Eligible for LUNA V2.0 Qualification and Respective U Rating Maximums	74
Table 23: LUNA V2.0 Light Distribution Requirements.....	76
Table 24: LUNA V2.0 Spectral Quality Requirements	79
Table 25: Turtle Lighting PUD Requirements: Light Output and Distribution	82
Table 26: Efficacy Allowances Specific to LUNA Products	85
Table 27: Field Adjustable Color Temperature Reported Data.....	88
Table 28: Field Adjustable Light Output and Wattage Reported Data	89
Table 29: Field Adjustable Light Distribution Reported Data	92
Table 30: Efficacy Requirements for All Amber LED Products	101
Table 31: Testing and Reporting Requirements for Spectral Quality for Products with Amber LEDs (DLC Standard).....	102
Table 32: Additional Reported Fields Required for Solar Powered Outdoor Luminaires.....	105
Table 33: Powered Device Minimum Input Voltage*	110
Table 34: Compatibility Testing Requirements: G24q- and GX24q-Base Lamps	117
Table 35: Type A and Dual Mode Reference Ballast Criteria	118



Table 36: Required Testing to Demonstrate Compliance With SSL V6.0 and LUNA V2.0 125

Table 37: Example of Shielded Products and Identified Worst-Case Efficacy and Distribution Parents.. 136

Table 38: FALD Testing and Reporting Requirements 138

Table 39: Data Reporting Format for FACT, CCT-Tunable, and Full Color-Tunable Product Submissions 141

Table 40: SSL V6.0 and LUNA V2.0 Technical Requirement Corrections and Clarifications (Published as Needed)..... 189



Part I: General Information

Technical Requirements for LED Lighting: SSL V6.0 and LUNA V2.0 introduces a new structure with eight major “Parts” to more clearly organize all SSL and LUNA Technical Requirements. This new structure is intended to improve navigation so readers can more quickly distinguish which part of the *Technical Requirements for LED Lighting policy* is relevant to their needs.

Part I establishes a foundation for the technical requirements by introducing the scope of the document and the DLC mission. Part I is also intended to ensure clarity by defining key terms, abbreviations, eligibility criteria, and more. With the context set in Part I, readers have a better understanding of the purpose and subsequent sections and technical requirements holistically.



1 Introduction

The DesignLights Consortium (DLC) is a nonprofit organization committed to accelerating the transition to energy efficient lighting and controls. Through rigorous qualification programs and stakeholder engagement, the DLC supports policies and programs that reduce energy use, carbon emissions, and light pollution, and that ultimately promote quality lighting and a more sustainable world. The DLC's work is enabled by stakeholder collaboration, which includes manufacturers, efficiency program administrators, and users of the QPLs who support the continued evolution of high-performing, energy efficient, non-residential¹ LED lighting solutions. Over the past 10 years, the LED revolution and manufacturer innovation has helped enable energy efficiency programs to achieve over 1,000 terawatt-hours (TWh) of lighting energy savings.

Released in 2020, SSL Version 5.1 marked the last major update to DLC's SSL requirements, emphasizing quality of light and controllability. Over the past 5 years, the DLC has engaged deeply with industry partners, including serving on standards development committees, conducting outreach, and developing studies that advance LED retrofits, energy efficient controls, and reduced light pollution.

Building on that foundation, the [*DLC Technical Requirements for LED Lighting: SSL V6.0 & LUNA V2.0*](#) unites previously separate documents into one streamlined set of qualification criteria for the Solid-State Lighting and LUNA Qualified Products Lists. Like all DLC updates, these requirements were shaped through extensive stakeholder input, including years of collaboration, a 2024 call for feedback, and two rounds of public comment.

Every change in this release represents thoughtful progress, being bold where it counts and practical where it matters to drive lasting impact. By setting clear, credible performance baselines, SSL V6.0 and LUNA V2.0 will accelerate innovation and spotlight technologies that save energy, enhance spectral quality, and deliver responsible, transparent lighting solutions communities can trust.

Beyond energy savings, the LUNA QPL is designed to mitigate and reduce light pollution by providing options to meet dark sky requirements and ordinances. The aim is not only to improve clarity and usability of the requirements, but also to reflect how LED lighting technology, and the needs of the shared market, continue to evolve.

¹ Non-residential, in this case, includes commercial, industrial, multifamily, and municipal sectors. Schools, universities, and hospitals are also considered in this group.

This version of the technical requirements reflect the dialogue and input gathered since the launch of SSL V5.1. It includes several key updates:

- A major revision to the DLC Premium classification, expanding beyond efficacy and quality to further enable incentives for advanced controls and integrated lighting systems
- Clear criteria and improved documentation for manufacturers and specifiers
- Alignment with technology advances in efficacy, quality of light, and system flexibility

Today’s modern luminaires serve as more than sources of light—they are enablers of connected, intelligent building systems. The SSL V6.0 and LUNA V2.0 technical requirements encourage adoption of these capabilities in a way that benefits everyone: efficiency programs, manufacturers, building owners, and end users.

1.1 Goals of the Technical Requirements



1.2 Definitions

Unless otherwise noted, the terms in this policy directly reference the definitions from the Illuminating Engineering Society (IES) [ANSI/IES LS-1-22, Lighting Science: Nomenclature and Definitions for Illuminating Engineering](#) and, where applicable, the International Lighting Vocabulary ([e-ILV](#)) by the International Commission on Illumination (CIE).

To facilitate understanding of terms and nomenclature used throughout the SSL Technical Requirements, the DLC has developed a standalone online resource referred to as *The DLC Glossary*, which can be found on the DLC website at <https://designlights.org/glossary>. This resource is not intended to be a comprehensive resource for the lighting industry, but rather a DLC-specific resource

intended to define terms with implications for DLC qualification. The following definitions include new terminology used in SSL V6.0 and LUNA V2.0.

Amber LEDs – There are no current consensus standards for Amber LEDs for general illumination, so the DLC is defining them for its use in SSL V6.0 and LUNA V2.0. Requirements for these LED types are given in *Amber Products*.

- **Direct-emission (de-) Amber LED** – Produced by a narrowband LED, such as an aluminum indium gallium phosphide (AlInGaP) LED.
- **Filtered Amber LED** – White LED (2200 K– 5000 K) lamp, retrofit kit or luminaire with an amber filtered lens or optic that reduces the short wavelength radiation.
- **Phosphor-converted (pc-) Amber LED** – Produced by a narrowband LED such as an indium gallium nitride (InGaN) LED paired with a reddish phosphor that completely, or nearly completely, down-converts the short wavelength radiation into longer wavelength broadband light.

Dominant wavelength – The principal wavelength of a light source’s hue in chromaticity space. It is calculated by projecting a straight line from the chromaticity coordinates of an equal energy spectrum through the light source’s chromaticity coordinates to the spectrum locus (adapted from [Webvision](#)).

Field adjustable – A feature of a luminaire, lamp, or retrofit kit that is intended to be changed at the time of installation and not over the course of normal operation.

Hawaii code compliant – As considered by the DLC: Products that have 2% or less blue light and that are traffic color compliant.

Lighting controller – A device that governs the output of a light source by integrating an LED driver and sensors such as occupancy and daylight into a communication network that may be wired (such as DALI2) or wireless (such as Zigbee or Bluetooth).

Non-white light (NWL) products – As considered by the DLC: Product types with 1800 K, 2000 K, and Amber LEDs. *Note:* The quadrangles for 1800 K and 2000 K are standardized in ANSI/NEMA C78.377-2024.

Percent blue - defined as the sum of the optical radiation between 400 and 500 nm divided by the sum of the optical radiation between 400 and 700 nm.

Scotopic/photopic (S/P) ratio – The ratio of the luminous output of a light [source](#) evaluated according to the CIE scotopic [spectral luminous efficiency](#) function, $V'(\lambda)$, divided by the luminous output evaluated according to the CIE photopic [spectral luminous efficiency](#) function, $V(\lambda)$ (per [CIE e-ILV](#)).

Traffic color compliant – Having a chromaticity outside of ITE Yellow (amber) (per SAE J578 APR2020). *Note:* This definition is included in the Hawaii and Maui County Code criteria used in LUNA V2.0 ($\leq 2\%$ blue and “traffic color compliant”).

Turtle lighting – Outdoor luminaires used in coastal areas where nesting sea turtles are present. They are typically constrained to using long-wavelength, direct-emission Amber LEDs, having zero direct-

uplight emissions, and a limit on total light output, high-angle light, and/or illumination levels. (Refer to [Table 25](#)).

1.3 Abbreviations

AC – alternating current

ANSI – American National Standards Institute

ASHRAE – American Society of Heating, Refrigerating, and Air-Conditioning Engineers

BA – beam angle

BUG – Backlight, Uplight, Glare

CCT – correlated color temperature

CFL – compact fluorescent lamp

CIE – International Commission on Illumination

CRI – color rendering index

CSA – Canadian Standards Association

CSS – cul-de-sac side shield

DC – direct current

de- – direct emission (e.g., de-Amber)

e-ILV – International Lighting Vocabulary

FACT – field adjustable color temperature

FALD – field adjustable light distribution

FALO – field adjustable light output

FSS – front side shield

HSS – house side shield

IEC – International Electrotechnical Commission

IES – Illuminating Engineering Society

ISO – International Organization for Standardization

ISTMT – in-situ temperature measurement testing

LED – light emitting diode

LEED – Leadership in Energy and Environmental Design

LLLC – luminaire level lighting control

LM – Lighting Measurement, as used by IES in its standards collection

LP – Lighting Practice, as used by IES in its standards collection

LS – Lighting Science, as used by IES in its standards collection

LSS – left side shield



LUNA – Light Usage for Night Applications
NEMA – National Electrical Manufacturers Association
NLC – Networked Lighting Control
NWL – Non-white light
OEM – original equipment manufacturer
OSHA – Occupational Safety and Health Administration
PF – power factor
PL – private label
PoE or POE – power over Ethernet
PUD – Primary Use Designation
QPL – Qualified Products List
RF – radio frequency
RSS – right side shield
SC – spacing criteria
SPD – spectral power distribution
SSL – solid-state lighting
THD – total harmonic distortion
TM – Technical Memorandum, as used by IES in its standards collection
TMP – temperature measurement point
TMP_{ps} – temperature measurement point for the power source
UGR – Unified Glare Rating
UL – Underwriters Laboratory
ZLD – zonal lumen distribution



2 Eligibility

2.1 Introduction

This section introduces the scope of product eligibility within SSL V6.0 and LUNA V2.0, represented via the taxonomic structure of Category, General Application, and Primary Use Designation (PUD). Requirements for eligible products are found throughout the other topic sections, and definitions for each PUD can be found in **Appendix A: Primary Use Designation Definitions**. These definitions contain descriptions of how to determine which PUD corresponds with each product submitted for qualification, which include requirements based on form factor, dimensions, and the intended and/or marketed application.

The purpose of the Category → General Application → PUD taxonomy is to create use-based distinctions between product types that utility and energy efficiency programs can use as a basic framework for incentive structures. Performance requirements are also built around this framework, with broader requirements at the Category level, moving to more specific requirements at the General Application level, and the most specific requirements at the PUD level. This structure is not intended to capture the wide range of applications observed in the market, and products within one PUD may still have significant variation.

SSL V6.0 and LUNA V2.0 bring significant expansion to product eligibility: *Non-white Light (NWL) LED Luminaires, Retrofit Kits, and Lamps; Solar Powered Outdoor Luminaires; Omnidirectional/Directional HID Replacement Lamps; and LUNA Turtle Lighting PUD Requirements*. To understand all product qualification criteria, the technical requirements must be read in their entirety. Some sections may pertain to every product (Part I: General Information, Part II: DLC Standard Requirements, and Part III: Requirements for DLC Premium), and others to specific product types or features (Part IV: Requirements for LUNA V2.0 and Part V: Requirements for Specialized Product Types).

For additional context on requirements throughout the document, refer to **Appendix B: Referenced Standards** for links to standards and references used in these technical requirements.

Table 1 shows all of the DLC technical requirements' current product categories, their general applications, and their PUDs.

Table 1: Categories, General Applications, and Primary Use Designations (PUD)

#	Category	General Application	Primary Use Designation (PUD)
1	Outdoor	Low Output	<ul style="list-style-type: none"> • Outdoor Pole/Arm-Mounted Area and Roadway Luminaire • Outdoor Pole/Arm-Mounted Decorative Luminaire
2		Mid Output	<ul style="list-style-type: none"> • Outdoor Zero-Uplight Wall-Mounted Area Luminaire • Outdoor Uplight-Emitting Wall-Mounted Area Luminaire
3		High Output	<ul style="list-style-type: none"> • Turtle Lighting Zero-Uplight Pole/Arm-Mounted Area and Roadway Luminaire³ • Turtle Lighting Zero-Uplight Wall-Mounted Area Luminaires³
4		Very High Output	<ul style="list-style-type: none"> • Turtle Lighting Zero-Uplight Bollard³ • Bollard • Parking Garage Luminaire • Fuel Pump Canopy Luminaire • Architectural Flood and Spot Luminaire • Stairwell and Passageway Luminaire • Hazardous Environment Area Luminaire • Sports Lighting • Specialty: _____
5	Indoor	Interior Directional	<ul style="list-style-type: none"> • Wall Wash Luminaire • Track or Mono-point Luminaire • Specialty: _____
6		Case Lighting	<ul style="list-style-type: none"> • Display Case Luminaire • Horizontal Refrigerated Case Luminaire • Vertical Refrigerated Case Luminaire • Specialty: _____
7		Troffer	<ul style="list-style-type: none"> • 2x2 Luminaires for Ambient Lighting of Interior Commercial Spaces • 1x4 Luminaires for Ambient Lighting of Interior Commercial Spaces • 2x4 Luminaires for Ambient Lighting of Interior Commercial Spaces • Specialty: _____
8		Linear Ambient	<ul style="list-style-type: none"> • Direct Linear Ambient Luminaire • Linear Ambient Luminaires With Indirect Component • Specialty: _____



#	Category	General Application	Primary Use Designation (PUD)
9		High-Bay	<ul style="list-style-type: none"> • High Bay Luminaire • High Bay Aisle Luminaire • Hazardous Environment High-Bay Luminaire • Indirect High-Bay Luminaire • Specialty: _____
10		Low-Bay	<ul style="list-style-type: none"> • Low-Bay Luminaire • Hazardous Environment Low-Bay Luminaire • Specialty: _____
11	<i>Outdoor Retrofit Kits^{1,2}</i>	Low Output	<ul style="list-style-type: none"> • Retrofit Kits for Outdoor Pole/Arm-Mounted Area and Roadway Luminaires • Retrofit Kits for Outdoor Pole/Arm-Mounted Decorative Luminaires • Retrofit Kits for Large Outdoor Pole/Arm-Mounted Area and Roadway Luminaires • Retrofit Kits for Outdoor Zero-Uplight Wall-Mounted Area Luminaires • Retrofit Kits for Parking Garage Luminaires • Retrofit Kits for Fuel Pump Canopy Luminaires
12		Mid Output	
13		High Output	
14		Very High Output	
15	<i>Indoor Retrofit Kit^{1,2}</i>	Troffer	<ul style="list-style-type: none"> • Linear Retrofit Kits for 2x2 Luminaires • Integrated Retrofit Kits for 2x2 Luminaires • Linear Retrofit Kits for 1x4 Luminaires • Integrated Retrofit Kits for 1x4 Luminaires • Linear Retrofit Kits for 2x4 Luminaires • Integrated Retrofit Kits for 2x4 Luminaires
16		Linear Ambient	• Retrofit Kits for Direct Linear Ambient Luminaires
17		High-Bay	• Retrofit Kits for High-Bay Luminaires
18		Low-Bay	• Retrofit Kits for Low-Bay Luminaires
11	<i>Solar Powered Outdoor Luminaires⁴</i>	Low Output	<ul style="list-style-type: none"> • Outdoor Pole/Arm-Mounted Area and Roadway Luminaire • Outdoor Pole/Arm-Mounted Decorative Luminaire • Outdoor Zero-Uplight Wall-Mounted Area Luminaire • Outdoor Uplight-Emitting Wall-Mounted Area Luminaire • Turtle Lighting Zero-Uplight Pole/Arm-Mounted Area and Roadway Luminaire³ • Turtle Lighting Zero-Uplight Wall-Mounted Area Luminaires³ • Turtle Lighting Zero-Uplight Bollard³ • Bollard • Parking Garage Luminaire • Fuel Pump Canopy Luminaire
12		Mid Output	
13		High Output	
14		Very High Output	



#	Category	General Application	Primary Use Designation (PUD)
			<ul style="list-style-type: none"> • Architectural Flood and Spot Luminaire • Stairwell and Passageway Luminaire • Hazardous Environment Area Luminaire • Sports Lighting • Specialty: _____
19	Linear Replacement Lamps	2' T8 Lamp	<ul style="list-style-type: none"> • Replacement Lamps ("Plug and Play") (UL Type A) • Internal Driver/Line Voltage (UL Type B) Lamp • 1-Lamp External Driver (UL Type C) Lamp • 2-lamp External Driver (UL Type C) Lamp • 3-lamp External Driver (UL Type C) Lamp • 4-lamp External Driver (UL Type C) Lamp • Dual Mode Internal Driver (UL Type A or B)
20		4' T8 Lamp	
21		4' T5 Lamp	
22		3' T8 Lamp	
23		8' T8 Lamp	
24		4' T5HO Lamp	
25		U-Bend Replacement Lamp	
26	Mogul Screw-Base (E39/E40) Replacements for HID Lamps ¹	Outdoor – Low Output	<ul style="list-style-type: none"> • Replacement Lamps for Outdoor Pole/Arm-Mounted Area and Roadway Luminaires (UL Type B) • Replacement Lamps for Outdoor Pole/Arm-Mounted Decorative Luminaires (UL Type B) • Replacement Lamps for Outdoor Zero-Uplight Wall-Mounted Area Luminaires (UL Type B) • Replacement Lamps for Parking Garage Luminaires (UL Type B) • Replacement Lamps for Fuel Pump Canopy Luminaires (UL Type B)
27		Outdoor – Mid Output	
28		Outdoor – High Output	
29		Outdoor – Very High Output	

#	Category	General Application	Primary Use Designation (PUD)
			<ul style="list-style-type: none"> • Replacement Lamps for Outdoor Pole/Arm-Mounted Area and Roadway Luminaires (UL Type C) • Replacement Lamps for Outdoor Pole/Arm-Mounted Decorative Luminaires (UL Type C) • Replacement Lamps for Outdoor Zero-Uplight Wall-Mounted Area Luminaires (UL Type C) • Replacement Lamps for Parking Garage Luminaires (UL Type C) • Replacement Lamps for Fuel Pump Canopy Luminaires (UL Type C)
30		High-Bay	<ul style="list-style-type: none"> • Replacement Lamps for High-Bay Luminaires (UL Type B) • Replacement Lamps for High-Bay Luminaires (UL Type C)
31		Low-Bay	<ul style="list-style-type: none"> • Replacement Lamps for Low-Bay Luminaires (UL Type B) • Replacement Lamps for Low-Bay Luminaires (UL Type C)
32		Omnidirectional/Directional Lamps	<ul style="list-style-type: none"> • Omnidirectional/Directional Replacement Lamps (UL Type B)
33	Medium Screw-Base (E26, E27) Replacement for HID Lamps ¹	Omnidirectional/Directional Lamps	<ul style="list-style-type: none"> • Omnidirectional/Directional Replacement Lamps (UL Type B)
35		Vertically Mounted Lamps	
36		Horizontally Mounted Lamps	<ul style="list-style-type: none"> • Replacement Lamps ("Plug and Play") (UL Type A)
37	Four Pin-Base Replacement Lamp for CFLs ¹	2G11 Base Lamps	<ul style="list-style-type: none"> • Replacement Lamps ("Plug and Play") (UL Type A) • Internal Driver/Line Voltage (UL Type B) Lamp • 1-Lamp External Driver (UL Type C) Lamp • 2-lamp External Driver (UL Type C) Lamp • 3-lamp External Driver (UL Type C) Lamp • Dual Mode Internal Driver (UL Type A or B)

Table notes:

1. Retrofit Kits, certain Mogul Screw-base Replacement Lamps, and G24q-base Four-Pin Replacement Lamps must be tested in reference luminaires, per the policies for those products. (Please refer to the [Lamps and Reference](#) for more detailed information on testing.)
2. Retrofit Kits are evaluated in specific PUDs only, and not as a general kit intended for unknown end-use applications.
3. Turtle Lighting PUDs must meet the requirements in LUNA Turtle Lighting PUD Requirements.
4. Further guidance on qualifying products in the Outdoor Solar Luminaire category may be found in the Solar Powered Outdoor Luminaires section.

2.2 Eligibility Guidance for the "Specialty" Primary Use Designation

Products with a Specialty designation are not eligible for DLC Premium qualification. The same model number cannot be used for both a specialty and a non-specialty product.

Principles for evaluating products submitted with the Specialty designation:

1. Products must meet the intended use of the broader category and general application group under which they are designated. For example, products seeking qualification with a designation of Outdoor Low Output-Specialty: _____ must be intended for use in outdoor applications.
2. Products must meet the minimum performance requirements of the broader category under which they are designated.
3. Products must report distribution data but are not required to meet specific distribution criteria.
4. Products must specify the end use for which they are intended. For example, products that are intended to be used for canopy lighting that seek qualification under the Specialty designation must indicate on the application form that their intended use is "Specialty: Canopy Lighting". DLC staff monitor terminology and may make minor modifications to descriptor terms to ensure consistency (for example, "Specialty: Canopy Lighting" vs. "Specialty: Canopy Luminaire"). Changes to descriptor terms will be made in consultation with the applicant.
5. As part of the evaluation of any new Specialty designation, the DLC will determine what dimming requirements apply to that designation. Additional details on the application and market for the end-use may be requested.
6. The DLC retains the right to deny the Specialty designation for any product that it does not believe meets the intended use of the designation. Judgment on eligibility will be at the sole discretion of the DLC program staff.

2.3 Eligibility for Hazardous Environment Products

Manufacturers submitting products labeled as suitable for hazardous environments must provide documentation that supports those claims. This documentation must clearly indicate that the model numbers in question are certified to the UL 844 standard and specify the Class and Division for which the products are certified. In cases where questions arise, the DLC will require that the documentation from the relevant safety organization explicitly identifies both the model numbers and the certification to the UL 844 standard.

2.4 Updates and Additions to Eligible PUDs

2.4.1 Non-white Light (NWL) LED Luminaires, Retrofit Kits, and Lamps

SSL V6.0 allows indoor and outdoor lamps, retrofit kits and luminaires to include LEDs with nominal CCTs of 1800 K and 2000 K, described by chromaticity quadrangles in ANSI/NEMA C78.377-2024. These nominal CCTs as well as Amber are defined as non-white light (NWL) by the DLC. (White light is

considered by the DLC to include nominal CCTs of 2200 K to 6500 K). NWL also includes the various types of Amber LED products (see the [Amber Products](#) section).

2.4.2 Omnidirectional/Directional HID Replacement Lamps

SSL V6.0 introduces two new HID replacement lamp PUDs that include bare-lamp testing and reporting requirements. They consist of omnidirectional/directional replacement lamps for mogul screw-base (E39/E40) and omnidirectional/directional replacement lamps for medium screw-base (E26) for HID lamps. This pathway allows manufacturers to use bare-lamp testing to demonstrate compliance with the bare-lamp efficacy, light output, and distribution threshold requirements in SSL V6.0.

Manufacturers may choose the most appropriate mogul screw-base PUD pathway for new or updated listings. Those who prefer to update products under existing PUDs that require in-luminaire testing may continue to do so, using Indoor and Outdoor General Application categories (e.g., Outdoor: Low Output, Low-Bay) to leverage existing test data. However, manufacturers should note that the in-luminaire minimum efficacy thresholds have increased in SSL V6.0.

Manufacturers wishing to list medium screw-base HID replacement lamps will also have a bare-lamp testing and reporting pathway in SSL V6.0. They will use the Omnidirectional/Directional General Application choice for Medium Screw-Base (E26) Replacements for HID Lamps (and related Type B lamp PUDs). Bare-lamp efficacy, light output, and distribution threshold requirements are provided in these technical requirements.



Part II: DLC Standard Requirements

Part II serves as the core set of technical requirements that must be met by all products submitted for qualification, regardless of program, classification, category, general application or primary use designation. Anchored in the DLC pillars—efficacy, quality of light, and controllability—Part II includes both performance and reporting requirements applicable to all products, including safety, warranty, power quality, sustainability, and more.

Subsequent Parts III through VI specify additional considerations (new or different from DLC Standard Requirements) and reporting requirements as well as details for demonstrating compliance for those classifications, categories, product types, and more.



3 Efficacy

3.1 Introduction

As part of the DLC’s mission to save energy and reduce carbon emissions, efficacy thresholds are set to reflect technological advancements, ensuring that DLC-qualified products represent the highest-performing products on the market. The efficacy thresholds in SSL V6.0 and LUNA V2.0 are determined based on efficacy trends among DLC-listed products, DOE market projections, and other sources.

3.2 Efficacy Requirements

Table 2 shows efficacy requirements for DLC Standard luminaires and retrofit kits within standardized CCT quadrangles (1800 K to 6500 K as applicable). *Table 3* shows minimum efficacy requirements for lamps (in-luminaire and bare-lamp, as applicable) within standardized CCT quadrangles. Turtle Lighting PUDs are excluded from *Table 2* as they are required to use de-Amber LEDs. Efficacy thresholds for Amber LED products are provided in *Efficacy Requirements for Amber LED products*.

Efficacy allowances and tolerances may apply for some product types. Information on efficacy allowances and on tolerances is provided in the *Efficacy Allowances*, and *Tolerances* sections, respectively. Efficacy thresholds for Premium qualification are provided in *Premium Eligibility*. All efficacy values must be tested according to ANSI/IES LM-79-19 or -24, and tested and reported efficacy values are displayed on the QPL. (For minimum testing requirements, see *Minimum Testing Requirements*.)

Table 2: DLC Standard Efficacy Requirements for Luminaires and Retrofit Kits Within Standardized CCT Quadrangles (1800 K to 6500 K as Applicable*)

Category	General Application	Primary Use Designation	DLC Standard Minimum Efficacy (lumens per watt, lm/W)
Outdoor Luminaires and Solar Powered Outdoor Luminaires	All	Outdoor Pole/Arm-Mounted Area and Roadway Luminaires	125
		Outdoor Pole/Arm-Mounted Decorative Luminaires	115
		Outdoor Zero-Uplight Wall-Mounted Area Luminaires	125
		Outdoor Uplight-Emitting Wall-Mounted Area Luminaires	125
		Bollards	115
		Parking Garage Luminaires	115
		Fuel Pump Canopy Luminaires	125
		Architectural Flood and Spot Luminaires	125
		Stairwell and Passageway	125

Category	General Application	Primary Use Designation	DLC Standard Minimum Efficacy (lumens per watt, lm/W)
		Sports Lighting	115
		Hazardous Environment Area Luminaires	115
		All Outdoor Specialty**	115
Indoor Luminaires	Interior Directional	All	95
	Case Lighting		105
	Troffer		120
	Linear Ambient		125
	High-Bay	All except Hazardous Environment High-Bay Luminaires	135
		Hazardous Environment High-Bay Luminaires	130
	Low-Bay	All except Hazardous Environment Low-Bay Luminaires	130
		Hazardous Environment Low-Bay Luminaires	125
Outdoor Retrofit Kits	All	Retrofit Kits for Outdoor Pole/Arm-Mounted Area and Roadway Luminaires	125
		Retrofit Kits for Outdoor Pole/Arm-Mounted Decorative Luminaires	115
		Retrofit Kits for Large Outdoor Pole/Arm-Mounted Area and Roadway Luminaires	125
		Retrofit Kits for Outdoor Wall-Mounted Area Luminaires	125
		Retrofit Kits for Parking Garage Luminaires	115
		Retrofit Kits for Fuel Pump Canopy Luminaires	125
Indoor Retrofit Kits	Troffer	All	120
	Linear Ambient		125
	High-Bay		135
	Low-Bay		130

* *Table note:* For applicable CCT ranges, please refer to the Spectral Quality requirements subsections ([Spectral Quality Requirements](#), [Premium Eligibility](#), and [LUNA Spectral Quality Requirements](#)). For applicable efficacy allowances, please refer to the [Efficacy Allowances](#) section.

** *Table note:* Unless specified, specialty products must meet the lowest minimum performance requirements within the broader category or general application under which they are designated.

Table 3: Standard Efficacy Requirements for Lamps Within Standardized CCT Quadrangles (1800 K to 6500 K as Applicable*) [In-Luminaire and Bare-Lamp]

Category	General Application	DLC Standard Minimum Efficacy (lm/W)	
		In-Luminaire	Bare-Lamp
Linear Replacement Lamps	2' T8 Lamps	N/A	130
	3' T8 Lamps		130
	4' T8 Lamps		130
	4' T5 Lamps		130
	4' T5HO Lamps		130
	8' T8 Lamps		130
	U-Bend Lamps		130
Mogul Screw-Base (E39/E40) Replacements for HID Lamps	Outdoor: Low Output	115	N/A
	Outdoor: Mid Output	115	
	Outdoor: High Output	115	
	Outdoor: Very High Output	115	
	High-Bay	135	
	Low-Bay	130	
	Omnidirectional/Directional	N/A	145
Medium Screw-Base (E26) Replacements for HID Lamps	Omnidirectional/Directional	N/A	130
Four Pin-Base Replacement Lamps for CFLs	Vertically-Mounted Lamps	80	90
	Horizontally-Mounted Lamps	80	90
	2G11 Base Lamps	N/A	125

* *Table note:* For applicable CCT ranges, please refer to the Spectral Quality requirements subsections ([Spectral Quality Requirements](#), [Premium Eligibility](#), and [LUNA Spectral Quality Requirements](#)). For applicable efficacy allowances, please refer to the [Efficacy Allowances](#) section.



4 Quality of Light

4.1 Introduction

The term “quality of light” encompasses the characteristics of lighting that include spectrum, distribution, and color maintenance, as well as application considerations such as uniformity, discomfort from glare, light trespass, and light pollution. DLC Standard quality of light requirements ensure basic quality of light performance for all listed products. Under this version of the technical requirements, a product’s quality of light is evaluated by its spectral quality, light output, and distribution, with additional considerations for discomfort from glare for the DLC Premium qualification. Additionally, this version of the technical requirements sets lower CCT thresholds for Outdoor PUDs, clarifies requirements for linear replacement lamps and omnidirectional and directional E26 and E39 lamps, and introduces optional reporting of ANSI/IES TM-35-19 CS4 and CS7 values.

4.2 Spectral Quality Requirements

The Spectral Quality Testing and Reporting Requirements for all SSL Standard products are as shown in

Table 4. DLC Premium spectral quality requirements are described in the *DLC Premium* requirement section. DLC LUNA spectral quality requirements are described in the LUNA Spectral Quality Requirements section. Amber LED spectral quality requirements are described in the *Amber Products* section. (For information on minimum required testing, see *Minimum Testing Requirements: DLC Standard Light Output and Distribution.*)

Table 4: Testing and Reporting Requirements for Spectral Quality (DLC Standard)

Metric and/or Application	Applicable Products	SSL V6.0 & LUNA V2.0 Standard Requirements	QPL Listing	Method of Measurement or Evaluation
Chromaticity (CCT & D _{uv})	Chromaticity must be consistent with at least one of the basic, flexible, or extended, nominal 7-step quadrangle CCTs detailed below:		CCT and D _{uv} for parent products from ANSI/IES LM-79 test reports are listed as Tested Data. Nominal CCT for child products is listed as Reported Data.	ANSI/IES LM-79 ANSI C78.377-2024
	All indoor products including linear replacement lamps and replacements for CFLs	1800 K – 6500 K		

Metric and/or Application	Applicable Products	SSL V6.0 & LUNA V2.0 Standard Requirements	QPL Listing	Method of Measurement or Evaluation
	All outdoor products including omnidirectional/ Directional E39 and E26 lamps, except Sports Lighting and Fuel Pump Canopy	1800 K – 5000 K		
	Sports Lighting and Fuel Pump Canopy	1800 K – 5700 K		
Color Rendition	Products are required to report data in terms of Option 1 and Option 2 but are only required to meet either Option 1 or Option 2 when thresholds are stipulated.		<p>All color rendition metrics for parent products from LM-79 test reports are listed as Tested Data.</p> <p>All color rendition metrics for child products are listed as Reported Data.</p>	<p>ANSI/IES LM-79</p> <p>ANSI/IES TM-30</p> <p>CIE 13.3-1995</p>
	All Indoor products (except high-bay and NWL) including linear replacement lamps and replacements for CFLs	<p>Option 1 - ANSI/IES TM-30:</p> <ul style="list-style-type: none"> • IES $R_f \geq 70$ • IES $R_g \geq 89$ • $-12\% \leq \text{IES } R_{cs,h1} \leq +23\%$ <p>Option 2 - CIE 13.3-1995:</p> <ul style="list-style-type: none"> • $R_a \text{ (CRI)} \geq 80$ • $R_9 \geq 0$ 		
	All Outdoor (except NWL), Omnidirectional /Directional E26 and E39 lamps, and high-bay products	<p>Option 1 - ANSI/IES TM-30:</p> <ul style="list-style-type: none"> • IES $R_f \geq 70$ • IES $R_g \geq 89$ • $-18\% \leq \text{IES } R_{cs,h1} \leq +23\%$ <p>Option 2 - CIE 13.3-1995:</p> <ul style="list-style-type: none"> • $R_a \text{ (CRI)} \geq 70$ • $R_9 \geq -40$ (high-bay only) <p>Outdoor must report R_9</p>		

Metric and/or Application	Applicable Products	SSL V6.0 & LUNA V2.0 Standard Requirements	QPL Listing	Method of Measurement or Evaluation
	All NWL products	<p>All NWL products must report the following metrics. No thresholds are stipulated.</p> <p>ANSI/IES TM-30:</p> <ul style="list-style-type: none"> • IES R_f • IES R_g • IES $R_{cs,h1}$ <p>CIE 13.3-1995:</p> <ul style="list-style-type: none"> • R_a (CRI) • R_9 		
<p>Color Maintenance 2</p>	<p>All Indoor products (except high-bay and NWL) including linear replacement lamps and replacements for CFLs</p>	<p>Chromaticity shift from ~1,000-hour measurement to ~6,000-hour measurement shall be within a linear distance of 0.004 ($\Delta u'v' \leq 0.004$) on the CIE 1976 (u', v') chromaticity diagram.</p> <p>Optional reporting of CS4 and CS7 values (without thresholds) per ANSI/IES TM-35-19.</p>	<p>CS4 and CS7 values will be displayed as Reported Data when reported.</p>	<p>ANSI/IES LM-80, and/or IES LM-84-14 and ANSI/IES TM-35-19</p>
	<p>All Outdoor (except NWL), omnidirectional and directional E26 and E39 lamps, and high-bay products</p>	<p>Chromaticity shift from ~1,000-hour measurement to ~6,000-hour measurement shall be within a linear distance of 0.007 ($\Delta u'v' \leq 0.007$) on the CIE 1976 (u', v') chromaticity diagram.</p> <p>Optional reporting of CS4 and CS7 values (without thresholds) per ANSI/IES TM-35-19.</p>		

² It is important to note that optional reporting of ANSI/IES TM-35-19 CS4 and CS7 values is included in SSL V6.0 and LUNA V2.0, and that reporting pathways will be provided coinciding with the availability of a publicly available TM-35 calculator. Custom calculators will not be accepted for reporting CS4 and CS7 values.

Metric and/or Application	Applicable Products	SSL V6.0 & LUNA V2.0 Standard Requirements	QPL Listing	Method of Measurement or Evaluation
	All NWL products	<p><i>All NWL products must report the following metrics. No thresholds are stipulated.</i></p> <p>Chromaticity shift on the CIE 1976 (u', v') chromaticity diagram from ~1,000-hour measurement to ~6,000-hour measurement shall be reported to the DLC.</p> <p>Optional reporting of CS4 and CS7 values per ANSI/IES TM-35-19.</p>		

4.3 Light Output and Distribution Requirements

4.3.1 Light Output

Table 5 describes the light output ranges that qualify for each General Application in the Outdoor Luminaire, Retrofit Kits, Lamps, and Solar Powered Outdoor Luminaire categories. All light output values must be tested according to ANSI/IES LM-79-19 or -24, and all tested and reported values are displayed on the QPL.

Table 5: Light Output Requirements by General Application for Outdoor Luminaires, Retrofit Kits and Lamps

Category	General Application	Light Output Range (lumens, lm)
Outdoor Luminaires, Solar Powered Outdoor Luminaires, Outdoor Retrofit Kits, Outdoor Mogul Screw-Base (E39/E40) Lamps	Low Output	150 – 5,000
	Mid Output	5,000 – 10,000
	High Output	10,000 – 30,000
	Very High Output	≥30,000

Table 6 describes the minimum light output needed for each PUD to be eligible for DLC qualification.

Table 6: Light Output Requirements by Primary Use Designation

Category	General Application	Primary Use Designation	Minimum Light Output (lm)
Outdoor Luminaires and Solar Powered Outdoor Luminaires	Note: Light Output requirements vary by General Application type (e.g. Low, Mid, High and Very High Output) See Table 5 above	Outdoor Pole/Arm-Mounted Area and Roadway Luminaires	1,000
		Outdoor Pole/Arm-Mounted Decorative Luminaires	1,000
		Outdoor Zero-Uplight Wall-Mounted Area Luminaires	300
		Outdoor Uplight Emitting Wall-Mounted Area Luminaires	300
		Bollards	150
		Parking Garage Luminaires	2,000
		Fuel Pump Canopy Luminaires	2,000
		Architectural Flood and Spot Luminaires	250
		Stairwell and Passageway Luminaires	750
		Hazardous Environment Area Luminaires	1,000
		Sports Lighting	1,000
		Turtle Lighting Zero-Uplight Pole/Arm-Mounted Area and Roadway Luminaires	250
		Turtle Lighting Zero-Uplight Wall-mounted Area Luminaires	250
		Turtle Lighting Zero-Uplight Bollards	150
Indoor Luminaires	Interior Directional	Wall-Wash Luminaires	575
		Track or Mono-Point Directional Luminaires	250
	Case Lighting	Vertical Refrigerated Case Luminaires-center	100 lm/ft
		Vertical Refrigerated Case Luminaires-end	50 lm/ft
		Horizontal Refrigerated Case Luminaires	100 lm/ft
		Display Case Luminaires	50 lm/ft
	Troffer	2x2 Luminaires for Ambient Lighting of Interior Commercial Spaces	2,000
		1x4 Luminaires for Ambient Lighting of Interior Commercial Spaces	1,500
		2x4 Luminaires for Ambient Lighting of Interior Commercial Spaces	3,000
	Linear Ambient	Linear Ambient Luminaires (Indirect Component)	500 lm/ft
		Direct Linear Ambient Luminaires	375 lm/ft
	High-Bay	High-Bay Luminaires	10,000
		High-Bay Aisle Luminaires	10,000
		Hazardous Environment High-Bay Luminaires	10,000
Indirect High-Bay Luminaires		10,000	
Low-Bay	Low-Bay Luminaires	5,000 – 10,000	



Category	General Application	Primary Use Designation	Minimum Light Output (lm)
		Hazardous Environment Low-Bay Luminaires	5,000
Outdoor Retrofit Kits	Note: Light Output requirements vary by General Application type (e.g. Low, Mid, High and Very High Output) See Table 5 above	Retrofit Kits for Outdoor Pole/Arm-Mounted Area and Roadway Luminaires	1,000
		Retrofit Kits for Outdoor Pole/Arm-Mounted Decorative Luminaires	1,000
		Retrofit Kits for Large Outdoor Pole/Arm-Mounted Area and Roadway Luminaires	1,000
		Retrofit Kits for Zero-Uplight Outdoor Wall-Mounted Area Luminaires	300
		Retrofit Kits for Parking Garage Luminaires	2,000
		Retrofit Kits for Fuel Pump Canopy Luminaires	2,000
Indoor Retrofit Kits	Troffer	Retrofit Kits for 2x2 Luminaires for Ambient Lighting of Interior Commercial Spaces (all PUDs)	2,000
		Retrofit Kits for 1x4 Luminaires for Ambient Lighting of Interior Commercial Spaces (all PUDs)	1,500
		Retrofit Kits for 2x4 Luminaires for Ambient Lighting of Interior Commercial Spaces (all PUDs)	3,000
	Linear Ambient	Retrofit Kits for Direct Linear Ambient Luminaires	375 lm/ft
	High-Bay	Retrofit Kits for High-Bay Luminaires	10,000
	Low-Bay	Retrofit Kits for Low-Bay Luminaires	5,000 (and l<10,000)
Linear Replacement Lamps	Four-Foot Linear Replacement Lamps (T8, T5)	All	1,600
	Four-Foot Linear Replacement Lamps (T5HO)	All	3,200
	Two-Foot Linear Replacement Lamps	All	800
	U-Bend Replacement Lamps	All	1,400
	Three-Foot Linear Replacement Lamps	All	1,200
	Eight-Foot Linear Replacement Lamps	All	3,200
Mogul Screw-Base (E39/E40) Replacements for HID Lamps (In Luminaire)	Note: Light Output requirements vary for outdoor products by General Application type (e.g. Low, Mid, High and	Mogul Screw-Base Replacements for HID Lamps in Outdoor Pole/Arm-mounted Area and Roadway Luminaires	1,000
		Mogul Screw-Base Replacements for HID Lamps in Outdoor Pole/Arm-mounted Decorative Luminaires	1,000

Category	General Application	Primary Use Designation	Minimum Light Output (lm)
	Very High Output) See Table 5 above	Mogul Screw-Base Replacements for HID Lamps in Outdoor Zero-Uplight Wall-mounted Area Luminaires	300
		Mogul Screw-Base Replacements for HID Lamps in Parking Garage Luminaires	2,000
		Mogul Screw-Base Replacements for HID Lamps in Fuel Pump Canopy Luminaires	2,000
	High-Bay	Mogul Screw-Base Replacements for HID Lamps in High-Bay Luminaires (Commercial and Industrial)	10,000
	Low-Bay	Mogul Screw-Base Replacements for HID Lamps in Low-Bay Luminaires (Commercial and Industrial)	5,000
Four Pin-Base Replacement Lamps for CFLs	Vertically Mounted Four Pin-Base Replacement Lamps for CFLs	All	In luminaire: 575 (1-lamp configuration)
			Bare lamp: 675
	Horizontally Mounted Four Pin-Base Replacement Lamps for CFLs	All	In luminaire: 800 (2-lamp configuration)
			Bare lamp: 675
2G11 Base Replacement Lamps for CFLs	All	1,900	
Mogul Screw-Base (E39/E40) Replacements for HID Lamps (Bare Lamp)	Omnidirectional/Directional Lamps	Omnidirectional/Directional Mogul Screw-Base Replacements for HID Lamps	2,000
Medium Screw-Base (E26) Replacements for HID Lamps (Bare Lamp)	Omnidirectional/Directional Lamps	Omnidirectional/Directional Medium Screw-Base Replacements for HID Lamps	2,000

* *Table note:* All output values must be tested according to ANSI/IES LM-79, and tested and reported light output values are displayed on the QPL. For minimum testing requirements, see [Minimum Testing Requirements: DLC Standard Light Output and Distribution](#).

** *Table note:* Unless specified, specialty products must meet the lowest minimum performance requirements within the broader category or general application under which they are designated

4.3.2 Light Distribution

The light distribution testing and reporting requirements for all SSL products qualifying for the DLC Standard qualification are shown in [Table 7](#). The “QPL Listing” column describes the information that appears as publicly available on the Qualified Products List, if applicable. The “Method of Evaluation” column describes how the products will be evaluated for qualification, whether by compliance with industry standards, manufacturer claims, or other DLC verification methodology. (For information on minimum required testing, see [Minimum Testing Requirements: DLC Standard Light Output and Distribution](#).)

Table 7: Testing and Reporting Requirements for Light Distribution (DLC Standard)

Metric and/or Data Set	SSL V6.0 Requirements			Method of Evaluation
	Threshold	Reported	QPL Listing	
Zonal Lumen Distributions (ZLD) & Spacing Criteria (SC) <i>All products except replacement lamps</i>	<i>Table 8</i>	Separate ZLD and SC reporting required for each product per Table 8	ZLD and SC information will not be published on the QPL	ANSI/IES LM-79 values produced by photometric analysis from tested IES-format files
Beam Angle <i>Linear replacement lamps and 2G11 lamps</i> <i>Omnidirectional/directional medium screw-base and mogul screw-base replacement lamps</i>	<i>Table 8</i>	Bare-lamp beam angle for each product	Beam angles are reported by the applicants and listed under the Reported Data section. Beam angles for parent products will be verified by the DLC using LM-79 test reports and listed as Tested Data.	ANSI/IES LM-79 Beam angle per ANSI/IES LS-1-22
Backlight, Uplight, and Glare (BUG) <i>Outdoor luminaires and retrofit kits only</i>	None	BUG ratings for each product	BUG ratings for child products are reported by the applicants and listed under the Reported Data section. BUG ratings for parent products will be generated by the DLC using tested photometric data and listed as Tested Data	BUG ratings generated per Annex A of ANSI/IES TM-15-20 using luminaire photometric data

The light distribution requirements for all SSL products are described in [Table 8](#).



Table 8: Primary Use Designation Technical Requirements: Light Distribution

Primary Use Letter	Primary Use Designation	Zonal Lumen Distribution (ZLD)/Spacing Criteria (SC)/Beam Angle (BA)*	ZL/SC/BA Nominal Requirement*	ZL/SC/BA Tolerance	ZLD/SC/BA Requirement with Tolerance
A	Outdoor Pole/Arm-Mounted Area and Roadway Luminaire	ZLD: 0° - 90°	100%	-1%	≥99%
		ZLD: 80° - 90°	≤10%	+3%	≤13%
B	Outdoor Pole/Arm-Mounted Decorative Luminaire	ZLD: 0° - 90°	≥65%	-3%	≥62%
C	Outdoor Zero-Uplight Wall-Mounted Area Luminaire	ZLD: 0° - 90°	100%	0%	100%
		ZLD: 80° - 90°	≤5%	+3%	≤8%
D	Outdoor Uplight Emitting Wall-Mounted Area Luminaire	ZLD: 80° - 90°	≤10%	+3%	≤13%
		ZLD: >90°	≤20%	+3%	≤23%
E	Bollard	ZLD: 90° - 110°	≤15%	+3%	≤18%
		ZLD: >110°	0%	+3%	≤3%
F	Parking Garage Luminaire	ZLD: 60° - 80°	≥30%	-3%	≥27%
		ZLD: 70° - 80°	≤25%	+3%	≤28%
G	Fuel Pump Canopy Luminaire	ZLD: 0° - 40°	≥40%	-3%	≥37%
		ZLD: 40-70°	≥40%	-3%	≥37%
I	Architectural Flood and Spot Luminaire	ZLD: 0° - 90°	≥85%	-3%	≥82%
J	Stairwell and Passageway Luminaire	ZLD: 0° - 90°	≥85%‡	-3%	≥82%
BA	Hazardous Environment Area Luminaire	ZLD: 0° - 90°	100%	-1%	≥99%
		ZLD: 80° - 90°	≤10%	+3%	≤13%
BB	Sports Lighting	ZLD: 0° - 90°	100%	1%	≥99%
K	Wall-wash Luminaire	ZLD: 0° - 90°	≥60%‡‡	-3%	≥57%
L	Track or Mono-Point Directional Luminaire	ZLD: 0° - 90°	≥85%	-3%	≥82%
M	Vertical Refrigerated Case Luminaire - center	ZLD: 10° - 90°†	≥95%†	-3%	≥92%
N	Vertical Refrigerated Case Luminaire - end	ZLD: 10° - 90°‡‡	≥95%‡‡	-5%	≥90%
O	Horizontal Refrigerated Case Luminaire	ZLD: 0° - 90°	≥95%	-3%	≥92%



Primary Use Letter	Primary Use Designation	Zonal Lumen Distribution (ZLD)/Spacing Criteria (SC)/Beam Angle (BA)*	ZL/SC/BA Nominal Requirement*	ZL/SC/BA Tolerance	ZLD/SC/BA Requirement with Tolerance
P	Display Case Luminaire	ZLD: 0° - 80°	≥95%	-5%	≥90%
Q	2x2 Luminaire for Ambient Lighting of Interior Commercial Spaces	SC: 0° - 180°	1.0 – 2.0	±0.1	0.9 – 2.1
		SC: 90° - 270°	1.0 – 2.0	±0.1	0.9 – 2.1
		ZLD: 0° - 60°	≥75%	-3%	≥72%
R	1x4 Luminaire for Ambient Lighting of Interior Commercial Spaces	SC: 0° - 180°	1.0-2.0	±0.1	0.9 – 2.1
		SC: 90° - 270°	1.0-2.0	±0.1	0.9 – 2.1
		ZLD: 0° - 60°	≥75%	-3%	≥72%
S	2x4 Luminaire for Ambient Lighting of Interior Commercial Spaces	SC:0° - 180°	1.0-2.0	±0.1	0.9 – 2.1
		SC:90° - 270°	1.0-2.0	±0.1	0.9 – 2.1
		ZLD:0° - 60°	≥75%	-3%	≥72%
T	Linear Ambient Luminaire (Indirect Component)	ZLD: 90° - 150°	≥35%	-3%	≥32%
U	Direct Linear Ambient Luminaire	ZLD: 0° - 60°	≥40%	-3%	≥37%
V	High-Bay Luminaire	ZLD: 20° - 50°	≥30%	-10%	≥20%
W	High-Bay Aisle Luminaire	ZLD: 20° - 50°	≥50%	-10%	≥40%
		ZLD: 0° - 20°	≥30%	-10%	≥20%
BC	Hazardous Environment High-Bay Luminaire	ZLD: 20° - 50°	≥30%	-10%	≥20%
BD	Indirect High-Bay Luminaire	ZLD: 90° - 180°	>90%	-3%	≥87%
X	Low-Bay Luminaire	ZLD: 20° - 50°	≥30%	-10%	≥20%
BE	Hazardous Environment Low-Bay Luminaire	ZLD: 20° - 50°	≥30%	-10%	≥20%
Y	Retrofit Kit for Outdoor Pole/Arm-Mounted Area and Roadway Luminaires	ZLD: 0° - 90°	100%	-1%	≥99%
		ZLD: 80° - 90°	≤10%	3%	≤13%
Z	Retrofit Kit for Outdoor Pole/Arm-Mounted Decorative Luminaire	ZLD: 0° - 90°	≥65%	-3%	≥62%
AA	Retrofit Kit for Large Outdoor Pole/Arm-Mounted Area and Roadway Luminaires	ZLD: 0° - 90°	100%	-1%	≥99%
		ZLD: 80° - 90°	≤10%	3%	≤13%
AB	Retrofit Kit for Zero-Uplight Outdoor Wall-Mounted Area Luminaires	ZLD: 0° - 90°	100%	0%	100%
		ZLD: 80° - 90°	≤5%	+3%	≤8%
AC	Retrofit Kit for Parking Garage Luminaires	ZLD: 60° - 80°	≥30%	-3%	≥27%
		ZLD: 70° - 80°	≤25%	+3%	≤28%
AD	Retrofit Kit for Fuel Pump Canopy Luminaires	ZLD: 0° - 40°	≥40%	-3%	≥37%
		ZLD: 40° - 70°	≥40%	-3%	≥37%



Primary Use Letter	Primary Use Designation	Zonal Lumen Distribution (ZLD)/Spacing Criteria (SC)/Beam Angle (BA)*	ZL/SC/BA Nominal Requirement*	ZL/SC/BA Tolerance	ZLD/SC/BA Requirement with Tolerance
AE	Retrofit Kit for 2x2 Luminaires for Ambient Lighting of Interior Commercial Spaces (all PUDs)	SC:0° - 180°	1.0 – 2.0	±0.1	0.90 – 2.1
		SC:90° - 270°	1.0 – 2.0	±0.1	0.90 – 2.1
		ZLD:0° - 60°	≥75%	-3%	≥72%
AF	Retrofit Kit for 1x4 Luminaires for Ambient Lighting of Interior Commercial Spaces (all PUDs)	SC:0° - 180°	1.0 – 2.0	±0.1	0.90 – 2.1
		SC:90° - 270°	1.0 – 2.0	±0.1	0.90 – 2.1
		ZLD:0° - 60°	≥75%	-3%	≥72%
AG	Retrofit Kit for 2x4 Luminaires for Ambient Lighting of Interior Commercial Spaces (all PUDs)	SC:0° - 180°	1.0 – 2.0	±0.1	0.90 – 2.1
		SC:90° - 270°	1.0 – 2.0	±0.1	0.90 – 2.1
		ZLD:0° - 60°	≥75%	-3%	≥72%
AH	Retrofit Kit for Direct Linear Ambient Luminaires	ZLD: 0° - 60°	≥40%	-3%	≥37%
AI	Retrofit Kit for High-Bay Luminaires	ZLD: 20° - 50°	≥30%	-10%	≥20%
AJ	Retrofit Kit for Low-Bay Luminaires	ZLD: 20° - 50°	≥30%	-10%	≥20%
AK	Four-Foot Linear Replacement Lamp (T8, T5: all PUDs)	Beam Angle	≥140°	-5°	≥135°
AL	Four-Foot Linear Replacement Lamp (T5HO: all PUDs)	Beam Angle	≥140°	-5°	≥135°
AM	Two-Foot Linear Replacement Lamp (all PUDs)	Beam Angle	≥140°	-5°	≥135°
AN	U-Bend Replacement Lamp (all PUDs)	Beam Angle	≥140°	-5°	≥135°
AO	Three-Foot Linear Replacement Lamp (all PUDs)	Beam Angle	≥140°	-5°	≥135°
AP	Eight-Foot Linear Replacement Lamp (all PUDs)	Beam Angle	≥140°	-5°	≥135°
AQ	Mogul Screw-Base Replacement for HID Lamp in Outdoor Pole/Arm-Mounted Area and Roadway Luminaires	ZLD: 0° - 90°	≥100%	-1%	≥99%
		ZLD: 80° - 90°	≤10%	3%	≤13%
AR	Mogul Screw-Base Replacement for HID Lamp in Outdoor Pole/Arm-Mounted Decorative Luminaires	ZLD: 0° - 90°	≥65%	-3%	≥62%



Primary Use Letter	Primary Use Designation	Zonal Lumen Distribution (ZLD)/Spacing Criteria (SC)/Beam Angle (BA)*	ZL/SC/BA Nominal Requirement*	ZL/SC/BA Tolerance	ZLD/SC/BA Requirement with Tolerance
AS	Mogul Screw-Base Replacement for HID Lamp in Outdoor Zero-Uplight Wall-Mounted Area Luminaires	ZLD: 0° - 90°	100%	0%	100%
		ZLD: 80° - 90°	≤5%	+3%	≤8%
AT	Mogul Screw-Base Replacement for HID Lamp in Parking Garage Luminaires	ZLD: 60° - 80°	≥30%	-3%	≥27%
		ZLD: 70° - 80°	≤25%	+3%	≤28%
AU	Mogul Screw-Base Replacement for HID Lamp in Fuel Pump Canopy Luminaires	ZLD: 0° - 40°	≥40%	-3%	≥37%
		ZLD: 40° - 70°	≥40%	-3%	≥37%
AV	Mogul Screw-Base Replacement for HID Lamp in High-Bay Luminaires	ZLD: 20° - 50°	≥30%	-10%	≥20%
AW	Mogul Screw-Base Replacement for HID Lamp in Low-Bay Luminaires	ZLD: 20° - 50°	≥30%	-10%	≥20%
AX	Vertically Mounted Four-Pin Base Replacement Lamp for CFLs	ZLD:0° - 60°	≥75%	-3%	≥72%
AY	Horizontally Mounted Four-Pin Base Replacement Lamp for CFLs	ZLD:0° - 60°	≥75%	-3%	≥72%
AZ	2G11 Base Replacement Lamp for CFLs	Beam Angle	≥140°	-5°	≥135°
BF	Turtle Lighting Zero-Uplight Pole/Arm-Mounted Area and Roadway Luminaire	ZLD: 0° - 90°	100%	0%	100%
BG	Turtle Lighting Zero-Uplight Wall-Mounted Area Luminaire	ZLD: 0° - 90°	100%	0%	100%
BH	Turtle Lighting Zero-Uplight Bollard	ZLD: 0° - 90°	100%	0%	100%
BI	Omnidirectional/Directional Mogul Screw-Base Replacement for HID Lamps	Beam Angle	≥80°	-5°	≥75°

Primary Use Letter	Primary Use Designation	Zonal Lumen Distribution (ZLD)/Spacing Criteria (SC)/Beam Angle (BA)*	ZL/SC/BA Nominal Requirement*	ZL/SC/BA Tolerance	ZLD/SC/BA Requirement with Tolerance
BJ	Omnidirectional/Directional Medium Screw-Base Replacement for HID Lamps	Beam Angle	≥80°	-5°	≥75°

Table notes:

- † Bilateral, symmetric light distribution on two hemispheres
- ‡‡ ≥60% of the lumens must be produced in the “forward” hemisphere, toward the wall (i.e., one-sided, single-hemisphere light distribution)
- ‡ Bilateral for surface-mounted units, single hemisphere for corner-mounted units
- * All distribution values must be tested according to ANSI/IES LM-79, and all tested and reported values are displayed on the QPL. For minimum testing requirements, see [Minimum Testing Requirements: DLC Standard Light Output and Distribution](#).

4.3.2.1 BUG (Backlight, Uplight, and Glare) Ratings

SSL products in the Outdoor Luminaire and Retrofit Kits categories shall report the six-character BUG ratings. The nomenclature of BUG Ratings is similar to this example: B2-U0-G2.

In addition, for products tested for distribution, tested BUG ratings will be generated by the DLC reviewer using the photometric data (IES-format file) and listed under the Tested Data section of the QPL.

Applicability to future Specialty Primary Use Designations will be determined on a case-by-case basis. The following Outdoor Low, Mid, High, or Very High Output PUDs are exempt from SSL V6.0 BUG rating reporting requirements:

- Architectural Flood and Spot Luminaires
- Specialty: Wall Grazing/Slicing
- Specialty: Hazardous Environment Flood and Spot Luminaires
- Specialty: Soffit Lighting
- Specialty: Natatorium Lighting
- Specialty: Tunnel Lighting
- Sports Lighting
- Lamp PUDs do not need to report BUG Ratings

4.4 Interactions With Other DLC Policies: Field Adjustable Light Distribution (FALD) and Field Adjustable Light Output (FALO)

For FALD products, additional clarifications on meeting light distribution and discomfort glare requirements are as follows:

- Testing and reporting requirements for zonal lumen distributions (ZLD) and spacing criteria (SC) are applicable to FALD products. The DLC review process will verify the ZLD requirements per the ZLD and SC measurements at the light distribution setting designated by the manufacturer per the *Field Adjustable Light Distribution (FALD) Testing and Reporting Requirements*.
- Testing and reporting requirements for BUG ratings are applicable to FALD products in the Outdoor Luminaire and Retrofit Kit categories, except for the PUDs that are exempted from reporting BUG Ratings (see *BUG (Backlight, Uplight, and Glare) Ratings*). This data will be displayed in the product detail page of the SSL QPL.
 - Tested BUG ratings will be listed on the SSL QPL under the Tested Data section.
 - Reported BUG ratings will be listed on the SSL QPL under the Reported Data section.
- Testing and reporting requirements for Unified Glare Rating (UGR) are applicable to FALD products in the applicable categories seeking Premium qualification. The UGR values shall meet the threshold at the light distribution setting designated, per the FALD Testing and Reporting Requirements, for meeting the ZLD requirements of the PUD, for which product qualification is sought.
- Testing and reporting requirements for UGR are applicable to FALD products for which efficacy allowances are sought. FALD products are eligible for efficacy allowances related to UGR under V6.0.

For FALO products, the minimum light output thresholds provided in *Light Output and Distribution Requirements* apply to the products at their maximum FALO setting (maximum wattage), and not at lower settings.



5 Controllability

5.1 Introduction

To better support expansion of energy efficiency incentive programs for luminaires with integral controls and controls-ready luminaires, SSL V6.0 and LUNA V2.0 add Controls Categories to associate products with specific integral controls options. Controls Categories are designed to align with energy savings claims associated with specific lighting control strategies, which are detailed in various Technical Resource Manuals (TRMs) and efficiency program policies. As TRMs govern many energy efficiency programs³, Controls Categories will simplify incentive program application and review processes and lower barriers to the adoption of advanced lighting by directly connecting model number variations of products with integral controls to lighting control strategies and their associated energy savings factors.

5.2 Controls Categories

Table 9 details the controls categories for all products.

Table 9: Controls Categories

ALL PRODUCTS		
Category	Name	Description
0	No Integral Controls	A luminaire, lamp, or retrofit kit with no integral control capabilities.
1	Controls Ready Product	A luminaire, lamp, or retrofit kit with controls-ready capability as defined in Controls Ready (Controls Category 1) .
2	Product With Non-DLC Listed NLC Controller	A luminaire, lamp, or retrofit kit with an integral networked controller installed at the factory that operates as part of NLC system that is not listed on the DLC NLC QPL.
3A	Product With Integral Occupancy or Traffic* Sensor Function Only	A non-networked luminaire, lamp, or retrofit kit (or a networked controller that operates as part of a NLC system that is not listed on the DLC NLC QPL) with only an integral occupancy or traffic sensor function, installed at the factory.

³ See the DLC Report [Lighting Controls and Technical Reference Manuals: Updates to Enhance Energy Savings](#) for more information.

ALL PRODUCTS		
Category	Name	Description
3B	Product With Integral Daylight/Photocell Sensor Function Only	A non-networked luminaire, lamp, or retrofit kit (or a networked controller that operates as part of a NLC system that is not listed on the DLC NLC QPL) with only an integral daylight/photocell sensor function, installed at the factory.
4A	Product With Occupancy or Traffic* and Daylight or Photocell Integral Sensor Functions	A non-networked luminaire, lamp, or retrofit kit (or a networked controller that operates as part of a NLC system that is not listed on the DLC NLC QPL) with occupancy and daylight/photocell integral sensor functions, installed at the factory. The sensor functions may be accomplished with a single device or multiple devices.
4B	Product With Traffic* or Photocell and/or Part-Night Dim Integral Sensor Functions	A non-networked luminaire, lamp, or retrofit kit (or a networked controller that operates as part of a NLC system that is not listed on the DLC NLC QPL) with photocell and part-night dim integral sensor functions, installed at the factory. The sensor functions may be accomplished with a single device or multiple devices.
5	Product With DLC NLC QPL Listed Networked Controller	A luminaire, lamp, or retrofit kit with an integral networked controller installed at the factory. The networked controller must operate as part of a DLC NLC QPL-listed control system.
6	Product With DLC NLC QPL Listed Networked Controller and Two or More Integral Sensor Functions (LLLL)	A luminaire, lamp, or retrofit kit with an integral networked controller and two or more sensor functions installed at the factory. The sensor functions may be accomplished with a single device or multiple devices. The networked controller must operate as part of a DLC NLC QPL-listed control system.

* *Table note:* Traffic sensing capability is restricted to outdoor listed products.

5.3 Driver and Integral Controller or Sensor Types

SSL V6.0 introduces two new reported fields, collected in the application process as noted in [Controls Options Tables](#) that describe the relevant methods of communication with listed products.

5.3.1 Driver Type

The Driver Type establishes the method by which a driver communicates with a lighting controller, whether the controller is remote mounted or integral to the luminaire, lamp, or retrofit kit. This method is always wired and may take place between a luminaire driver and a remote-mounted controller (e.g., a wallbox dimmer), within a luminaire between an integral controller and the driver, or, in the case of a

combined driver/controller, within the same luminaire component. This method can also be described as the communication method between the lighting controller and luminaires or the back-end communication method.

5.3.2 Integral Controller or Sensor Type

The Integral Controller or Sensor Type establishes the method by which an integral controller or sensor communicates with a remote-mounted control device or system. This method may be wired or wireless. This method can also be described as communication between devices within the lighting control system or the front-end communication method.

5.4 Controls Ready (Controls Category 1)

Controls Ready luminaires, lamps, and retrofit kits are defined as products with an integral controls receptacle onto which controls accessories can be installed in the field without modifying the product or using additional materials; are capable of supporting the functionality of the control accessory; and are purchased separately from the controls accessory.

Luminaires that ship with both an integral control device and a controls-ready receptacle shall be assigned a controls category according to the capabilities of the integral control device.

The following are some examples of luminaires, lamps, and retrofit kits that do and do not qualify as Controls Ready. These examples are presented for clarity and do not represent an exhaustive list.

- Qualifies as Controls Ready:
 - An outdoor area light with a NEMA 5-pin twistlock connector installed at the factory.
 - An indoor troffer with a Zhaga Book 20 socket installed at the factory.
- Does not qualify as Controls Ready:
 - A luminaire with an available knockout for field mounting a sensor or controller. Requires modifying the luminaire (removing the knockout) and utilizing additional materials (e.g., wire nuts, electrical tape)
 - A luminaire that ships from the factory with a knockout-mounted sensor that is demounted for packing purposes (this would be considered an integral sensor).

Controls Ready receptacle types are defined in [Table 10](#). These features will not be evaluated against any standards and will be treated as manufacturer-reported assertions validated with references on the product specification sheet or supplemental literature.

5.4.1 Controls Ready Receptacle Types

The receptacle types shown in [Table 10](#) are intended to indicate mechanical fit only, not full interoperability. The DLC will rely on individual manufacturers to indicate which controls-ready accessories are both mechanically and electrically compatible with associated controls-ready luminaires.



SSL V6.0 excludes luminaires with 3-pin twist lock (NEMA/ANSI C136.10-Compliant) receptacles from listing due to their inability to dim via a signal from the twistlock device. The 3-pin twistlock receptacle type is included in [Table 10](#) for completeness and to positively show on the QPL that a product variant with a 3-pin twistlock Controls Option Code is *not* qualified.

Products with twistlock receptacles or sensors/controls installed in a twistlock receptacle must explicitly describe the receptacle type as one of the controls-ready receptacle types within Table 10 on the specification sheet. Those receptacle types will be assumed to be 3-pin and that variation is not considered DLC qualified and will be displayed on the QPL as ‘Not DLC Qualified’.

Product variations with a 3-pin twistlock receptacle AND an integral sensor or controller may be listed and will be qualified according to the capabilities of the integral sensor. The integral sensor must be reflected in the documentation of the product variations being qualified.

Product variations with a 3-pin twistlock receptacle in addition to another receptacle where the sensor or controller is ordered separately from the luminaire are not eligible for listing.

Table 10: Controls Ready Receptacle Types

Receptacle Type	Definition	Acceptable Terms on the Product Specification Sheet or Supplemental Literature
None	No controls-ready receptacle is present on the luminaire. Products without a receptacle are not eligible for the Controls Ready category.	N/A
3-Pin Twistlock	A receptacle with three conducting pins that is installed at the factory and meets the NEMA/ANSI C136.10 standard. Please note that luminaires with 3-pin receptacles are NOT eligible for listing. This option is included here for completeness and to clearly communicate when specific controls options are <i>not</i> eligible.	N/A Please note that luminaires with 3-pin receptacles are NOT eligible for listing.
5-Pin Twistlock	A receptacle with five conducting pins that is installed at the factory and meets the NEMA/ANSI C136.41 standard.	NEMA 5-pin NEMA/ANSI 5-pin NEMA 5-pin twistlock NEMA/ANSI 5-pin twistlock
7-Pin Twistlock	A receptacle with 7 conducting pins that is installed at the factory and meets the NEMA/ANSI C136.41 standard.	NEMA 7-pin NEMA/ANSI 7-pin NEMA 7-pin twistlock NEMA/ANSI 7-pin twistlock
3.5 mm Phono Jack	A receptacle with three, four, or five contact points that is similar in shape or size to standard headphone jacks for consumer use.	3.5 mm Phono Jack 1/8" Phono Jack AUX Port

USB-C Port	A receptacle that is installed at the factory and meets the USB-C requirements for physical characteristics as specified in the IEC 62680-1-3 standard. The electrical characteristics of the receptacle may be proprietary.	USB-C USB Type-C
Zhaga Book 18	A receptacle installed at the factory that meets Zhaga Book 18 requirements. Designed for outdoor installations.	Zhaga Book 18
Zhaga Book 20	A receptacle installed at the factory that meets the Zhaga Book 20 requirements. Designed for indoor installations.	Zhaga Book 20
Z10	A receptacle installed at the factory that meets the Z10 socket standard developed by the Z10 Alliance. Designed for outdoor installations.	Z10
Other	Other receptacle type as specified by the luminaire manufacturer.	N/A

5.5 Controls Options Tables

Controls options tables contain information on all available controls options included in the model number and listed on the specification sheet for a luminaire, lamp, or retrofit kit.

Table 11 shows the details of the controls information collected from the controls options tables for all products.

Table 11: Controls Options Table Details

Controls Information	Description	Available Options
Controls Option Code	A text string that represents the controls options available for each driver and integral control variation within a model number. Each Controls Options Code must be orderable and shown on the specification sheet. Non-controls portions of model numbers that fall in between controls portions of model number codes may utilize wildcards in controls options codes.	As displayed on the specification sheet. For products without controls options, use "None."
Driver Type	The type of driver, designated by communication method, that is installed in the product, or ordered with the product in the case of remote-mounted drivers. Available options must be indicated on the specification sheet, but an exact match is not required.	<ul style="list-style-type: none"> • 10V (wired) • BACnet (wired) • D4i (wired) • DALI-2 (wired) • DALI-2/D4i (wired) • DALI-2/DALI+ (wired, wireless) • DALI-2/D4i/DALI+ (wired, wireless) • DALI (wired) • Dimmable Ballast (Type A lamps)

Controls Information	Description	Available Options
		<ul style="list-style-type: none"> • DMX512 (wired) • Integrated Driver and Controller • KNX (wired) • Modbus (wired) • Other analog (wired, proprietary) • Other digital (wired, proprietary) • Phase Cut (wired) • Phase Cut/10V (wired) • FALO (lamps only)
<p>Dimming Capability</p>	<p>The type of dimming the driver associated with this option code is capable of performing.</p>	<ul style="list-style-type: none"> • Continuous • Stepped • Not dimmable
<p>Minimum Dimming Level</p>	<p>The lowest level a driver is capable of dimming to, expressed as a percentage of total output.</p>	<ul style="list-style-type: none"> • Minimum dimming level (e.g., 10%)
<p>Integral Controller or Sensor Type</p>	<p>The type of integral controller or sensor, designated by communication method, that is installed in the product.</p> <p>Available options must be indicated on the specification sheet, but an exact match is not required.</p>	<ul style="list-style-type: none"> • None • Bluetooth (wireless, proprietary) • Bluetooth NLC (wireless) • DALI-2 (wired) • DALI-2/D4i (wired) • DALI-2/DALI+ (wired, wireless) • DALI-2/D4i/DALI+ (wired, wireless) • DALI (wired) • DALI+ (wireless) • Wi-Fi (wireless) • Zigbee (wireless, proprietary) • DMX512 (wired) • EnOcean (wireless) • 4G Cellular (wireless) • 5G Cellular (wireless) • BACnet (wired) • Modbus (wired) • KNX (wired) • Other (wireless, proprietary) • Other analog (wired, proprietary) • Other digital (wired, proprietary) • PoE (wired) • TALQ (wireless) • Infrared (wireless, proprietary) • Dip Switch or Dial



Controls Information	Description	Available Options
<p>Top or Side Controls Receptacle Type</p>	<p>The type of controls ready receptacle, installed at the factory, that is present on the top or side of the product when mounted in operating orientation.</p> <p>Available options must be indicated on the specification sheet or supplemental materials, but an exact match is not required.</p> <p>Product variations with 3-pin twistlock receptacles are not eligible for V6.0 qualification. Option is shown here for data integrity.</p> <p><u>Please note that any twistlock receptacle indicated will be assumed to have 3-pins, and thus not eligible for listing, unless clearly indicated as having 5 or 7-pins on the specification sheet.</u></p>	<ul style="list-style-type: none"> • None • 7-Pin twistlock • 5-Pin twistlock • 3-Pin twistlock (not eligible) • Zhaga Book 18 • Zhaga Book 20 • Z10 • USB C Port • 3.5 mm Phono Jack • Other
<p>Bottom or Side Controls Receptacle Type</p>	<p>The type of controls ready receptacle, installed at the factory, which is present on the bottom or side of the product when mounted in operating orientation.</p> <p>Available options must be indicated on the specification sheet or supplemental materials, but an exact match is not required.</p> <p>Product variations with 3-pin twistlock receptacles are not eligible for V6.0 qualification. Option is shown here for data integrity.</p> <p><u>Please note that any twistlock receptacle indicated will be assumed to have 3-pins, and thus not eligible for listing, unless clearly indicated as having 5 or 7-pins on the specification sheet.</u></p>	<ul style="list-style-type: none"> • None • 7-Pin twistlock • 5-Pin twistlock • 3-Pin twistlock (not eligible) • Zhaga Book 18 • Zhaga Book 20 • Z10 • USB C Port • 3.5 mm Phono Jack • Other
<p>Integral Sensor Function</p>	<p>The lighting control strategy or strategies that are performed by the integral sensor installed at the factory.</p> <p>Available options must be indicated on the specification sheet or supplemental materials, but an exact match is not required.</p>	<ul style="list-style-type: none"> • None • Occupancy only • Daylight only • Photocell only • Traffic only • Occupancy + Daylight • Occupancy + Photocell • Photocell + Part-Night Dim • Occupancy + Photocell + Part-Night Dim

Controls Information	Description	Available Options
		<ul style="list-style-type: none"> • Traffic + Photocell • Traffic + Photocell + Part-Night Dim
Integral Sensor Technology	The type of sensing technology that the integral sensor installed at the factory uses. Available options must be indicated on the specification sheet or supplemental materials, but an exact match is not required.	<ul style="list-style-type: none"> • None • Passive Infrared (PIR) • Ultrasonic • Dual-Tech • Microphonic • Microwave • Millimeter Wave • Camera • Bluetooth Beacon • Light-dependent Resistor • Other
Integral Sensor Maximum Mounting Height (ft)	The manufacturer-provided maximum mounting height for effective operation of the sensor.	One- or two-digit integer. Value to be submitted in feet. Both feet and meters will be displayed on the QPL.
NLC QPL Product ID	The NLC QPL Product ID of the networked lighting control system that the integral control product communicates with.	As displayed on the NLC QPL.
Controls Ready Accessory Model Numbers	Model numbers for the controls-ready accessories provided by the manufacturer that are compatible with the listed product. This field is optional for manufacturers to report.	As displayed on the specification sheet.

5.6 Dimming Requirements

These dimming requirements enhance the controllability of qualified lighting products across all categories to increase potential energy savings while improving quality of light, comfort, and well-being for end users of the occupied spaces. These policies will ensure that products listed on the SSL QPL have the capability of being dimmed. SSL QPL products designated as dimmable may require the installation of additional components and/or building infrastructure to enable dimming. The DLC does not set requirements regarding how qualified dimmable products are installed and/or used in the field.

The DLC does *not* issue requirements pertaining to utilization of a specific dimming control protocol (e.g., 0-10V, DALI) for the dimming capability requirement. *The ability to dim is the focus of this requirement.*

Table 12 shows the dimming requirements for all Standard listed products.

Table 12: Standard Dimming Requirements

Product Type	Standard Dimming Requirements	QPL Listing	Method of Evaluation
Indoor luminaires and retrofit kits (excluding Case Lighting, Specialty and Hazardous Primary Use Designations)	Continuous dimming capability to a minimum output level of 20% or lower*	<ol style="list-style-type: none"> 1. Dimming capability (i.e., continuous, stepped, or none) 2. Minimum dimming level (e.g., 10%) 	Product specification sheet shall clearly identify dimming capability
Indoor Case Lighting, Specialty and Hazardous Primary Use Designations	Reporting of dimming capability		
Outdoor luminaires, retrofit kits, (excluding Sports Lighting, Specialty and Hazardous Primary Use Designations)	Continuous or stepped dimming capability to a minimum output level of 20% or lower*		
Outdoor Sports Lighting, Specialty and Hazardous Primary Use Designations	Reporting of dimming capability		
All lamps	Continuous dimming capability to a minimum output level of 20% or lower* or FALO		
All other products	Required reporting of dimming capability		

* *Table note:* Control capabilities are based on manufacturer claims; performance is not verified by the DLC.

5.7 Special Controllability Considerations for Dimmable Lamps

As stated in [Table 12](#), all qualified lamps must be continuously dimmable or be capable of field adjustable light output (FALO). Because lamps are most often used in retrofit installations, there are special considerations needed to ensure that end users are able to dim lamps as desired. The following considerations apply to each UL Type of linear replacement lamps, mogul-screw base lamps, medium-screw base lamps, and pin-based replacement lamps, as appropriate:

UL Type A:

- For Type A lamps, with the exceptions noted below, capable of wired dimming solely via input from the existing ballast, the minimum dimming level should be noted. In addition, the “Wired – Dimmable Ballast” option in the “Driver Type” column should be selected, as well as “None” in the “Integral Controller or Sensor Type” column of the associated controls options table, as wired control signals are received by the ballast and not by the lamp itself. All other fields should be filled in as applicable.
 - Due to the lack of dimmable ballasts available in the marketplace for eight-foot T8 fluorescent lamps, Type A lamps in the T8 eight-foot general application that claim wired dimming capability utilizing the direct input from the ballast to achieve dimming will be rejected. Therefore, these lamp types that claim to be dimmable via a wired protocol must provide a wiring diagram in the product specification sheet, installation instructions, or separate document showing the electrical circuit of the lamp connecting to mains power via the ballast, including the location of the input signal from an external control source to the lamp.
 - Any Type A lamps which do not solely utilize the ballast input to achieve dimming capability through a wired protocol (i.e., the dimming control wires connect directly to the lamp), must report the specific wired communication protocol and provide a wiring diagram.
 - For the two exceptions above, if an external device is used between the dimming control user interface and Type A lamp, then the communication method between the lamp and external device must be reported as the Driver Type, and the communication method between the dimming control user interface and the external device must be reported as the Integral Controller or Sensor Type. The required wiring diagram noted above will be evaluated by reviewers to determine if an external device is required to achieve the specific communication protocol.
 - The DLC acknowledges that for Type A lamps the minimum dimming level achievable in the field is dependent on the capabilities of the existing dimming ballast and that minimum level may be higher than these requirements. The capabilities of existing dimming ballasts is beyond the scope of these Technical Requirements.

UL Type B:

- In addition to reporting minimum dimming level, presence of integral controls, and communication methods, for Type B lamps claimed to be dimmable via a wired communication method other than phase cut, a wiring diagram must be provided in the product specification sheet, installation instructions, or a separate document, showing the electrical circuit of the lamp connecting to mains power, including the location of the input signal from an external control source to the lamp or lamp holder for wired control.

UL Type A/B Dual Mode:

- Type A/B lamps must be dimmable in both modes of operation, and this must be stated on the product specification sheet.

- All requirements from UL Type A above apply to UL Type A/B Dual Mode. All products will have a note on the QPL that says: “When operated as Type A, dimmable depending on ballast capability.”
- Similarly, documentation must be supplied for Dual Mode lamps as noted in the Type B section above. This will be listed on the QPL as described for Type B lamps. If the Type B lamp accomplishes dimming with an external accessory, the QPL will include a note that is specific to Type B operation.

UL Type C:

- Type C lamps must meet all V6.0 Controllability requirements with no further considerations.

5.8 Integral Controls

Reporting of integral control function, technology, and maximum mounting height is required for all products.

Integral sensor functions are defined in [Table 13](#). These integral control functions will not be evaluated against any standards and are treated as manufacturer-reported assertions validated with references on the product specification sheet or supplemental literature.

Table 13: V6.0 Integral Sensor Functions

Integral Sensor Functions	Definition	Acceptable Terms on the Product Specification Sheet or Supplemental Literature
None	A product that has no integral sensor functions.	N/A
Occupancy Only	A control device that detects occupant presence and automatically turns luminaires and/or other equipment on and, after a preset delay during which no presence is detected, turns them off. Also called a motion detector.	Occupancy, Vacancy, Motion, Exterior Motion
Daylight Only	A control device that can automatically affect the operation of lighting or other equipment through dimming based on the amount of daylight and/or ambient light that is present in a space or area.	Daylight, Daylight Harvesting, Daylight Dimming, Daylight Response, Photosensor, Ambient Light
Photocell Only	A control device that can automatically affect the operation of lighting or other equipment based on the amount of daylight and/or ambient light that is present in an exterior environment.	Photocell, Photo, PCR, Dusk-to-Dawn, Photocontrol
Traffic	A control device that can automatically affect the operation of lighting or other equipment based upon detecting the presence or absence of moving vehicles in an area.	Traffic, Adaptive Traffic



Integral Sensor Functions	Definition	Acceptable Terms on the Product Specification Sheet or Supplemental Literature
Occupancy + Daylight	A control device that detects occupant presence and automatically turns luminaires and/or other equipment on and, after a preset delay during which no presence is detected, turns them off, in addition to automatically raising or lowering the dimming levels of lighting or other equipment based on the amount of daylight and/or ambient light that is present in a space or area.	Must include one or more terms from each of the following lists: Occupancy terms: Occupancy, Vacancy, Motion, Exterior Motion. Daylight terms: Daylight, Daylight Harvesting, Daylight Dimming, Daylight Response, Photosensor, Ambient Light.
Occupancy + Photocell	A control device that detects occupant presence and automatically turns luminaires and/or other equipment on and, after a preset delay during which no presence is detected, turns them off, in addition to automatically affecting the operation of lighting or other equipment based on the amount of daylight and/or ambient light that is present in an exterior environment.	Must include one or more terms from each of the following lists: Occupancy terms: Occupancy, Vacancy, Motion, Exterior Motion. Photocell terms: Photocell, Photo, PCR, Dusk-to-Dawn, Photocontrol.
Photocell + Part-Night Dim	A control device that can automatically affect the operation of lighting or other equipment based on the amount of daylight and/or ambient light that is present in an exterior environment and is capable of dimming the luminaire, lamp, or retrofit kit for a portion of nighttime hours without input from another device.	Must include one or more terms from each of the following lists: Photocell terms: Photocell, Photo, PCR, Dusk-to-Dawn, Photocontrol. Part-Night Dim terms: Part Night Dim, Stand-Alone Dimming.
Occupancy + Photocell + Part-Night Dim	A control device that detects occupant presence and can automatically affect the operation of lighting or other equipment based on the amount of daylight and/or ambient light that is present in an exterior environment and is capable of dimming the luminaire, lamp, or retrofit kit for a portion of nighttime hours without input from another device.	Must include one or more terms from each of the following lists: Occupancy terms: Occupancy, Vacancy, Motion, Exterior Motion. Photocell terms: Photocell, Photo, PCR, Dusk-to-Dawn, Photocontrol. Part-Night Dim terms: Part-Night Dim, Stand-Alone Dimming.
Traffic + Photocell	A control device that detects the presence of moving vehicles and automatically turns luminaires and/or other equipment on and, after a preset delay during which no presence is detected, turns them off, in addition to automatically affecting the operation of lighting or other equipment based on the amount of daylight and/or ambient light that is present in an exterior environment.	Must include one or more terms from each of the following lists: Traffic terms: Traffic Sensing, Vehicle Sensing. Photocell terms: Photocell, Photo, PCR, Dusk-to-Dawn, Photocontrol.

Integral Sensor Functions	Definition	Acceptable Terms on the Product Specification Sheet or Supplemental Literature
Traffic + Photocell + Part-Night Dim	A control device that detects the presence of moving vehicles and can automatically affect the operation of lighting or other equipment based on the amount of daylight and/or ambient light that is present in an exterior environment and is capable of dimming the luminaire, lamp, or retrofit kit for a portion of nighttime hours without input from another device.	Must include one or more terms from each of the following lists: Traffic terms: Traffic Sensing, Vehicle Sensing. Photocell terms: Photocell, Photo, PCR, Dusk-to-Dawn, Photocontrol. Part-Night Dim terms: Part Night Dim, Stand-Alone Dimming.

Integral sensor technologies are defined in [Table 14](#). Integral sensor technologies will not be evaluated against any standards and are treated as manufacturer-reported assertions validated with references on the product specification sheet or supplemental literature.

Table 14: V6.0 Integral Sensor Technologies

Integral Sensor Technologies	Definition	Acceptable Terms on the Product Specification Sheet or Supplemental Literature
Passive Infrared	Presence sensors that detect the movement of heat emitted by people in motion. Detection requires line of sight and does not function behind obstacles or through glass. Sensors typically have distance ratings for effectiveness at detecting major and minor motion.	Passive Infrared, PIR
Ultrasonic	Presence sensors that emit high-frequency acoustic waves and then monitor the pattern of reflections in a space. When the pattern is interrupted, the sensor registers movement. Ultrasonic sensors do not require a direct line of sight to function.	Ultrasonic
Microwave	Presence sensors that emit extremely low-power electromagnetic radiation in the range of 300 MHz to 300 GHz and then monitor the pattern of reflections in a space. When the pattern is interrupted, the sensor registers movement. Microwave sensors do not require a direct line of sight to function and can sometimes “see” through walls. Thus, proper adjustment of sensitivity settings is crucial to avoid false activations.	Microwave

Integral Sensor Technologies	Definition	Acceptable Terms on the Product Specification Sheet or Supplemental Literature
Microphonic	Presence sensors that use a sensitive microphone to detect sounds in a space, e.g., human activity such as talking, typing, or movement -- then applying advanced digital filtering to distinguish these sounds from constant background noises such as those from HVAC systems.	As indicated on Manufacturer specification sheet
Millimeter Wave	Presence sensors that emit electromagnetic radiation in the range of 30 to 300 GHz. Unlike ultrasonic and microwave sensors, millimeter wave radar sensors are able to detect movement, acceleration, and angles as small as a fraction of a millimeter and are sometimes capable of detecting multiple people in a space.	Millimeter Wave, mmWave
Camera	Presence sensors that utilize captured images, whether high or low resolution, and image processing software to determine human proximity.	As indicated on Manufacturer specification sheet
Dual Technology	Presence sensors that utilize two or more technologies to increase detection reliability.	Dual-Technology, Dual-Tech, Dual Technology, Dual Tech
Bluetooth Beacon	A Bluetooth device, normally battery powered, that broadcasts typically static data at preset intervals. Beacons are one-way communication devices that are not capable of receiving information over a Bluetooth network.	Bluetooth Beacon
Other	Presence sensors that utilize another technology, not listed above.	As indicated on Manufacturer specification sheet

5.9 Control Communication

Reporting of the Driver Type and Integral Controller or Sensor Type for all products is required. For luminaires without integral controls, “None” shall be entered in the “Integral Controller or Sensor Type” column of the controls options table. In the case of a luminaire with a driver and integral occupancy sensor, the occupancy sensor is considered the “integral controller,” and the method used to communicate with the occupancy sensor shall be listed as the Integral Controller or Sensor Type.

The Driver Type and the Integral Controller or Sensor Type are defined in [Table 15](#). These types will not be evaluated against any standards and will be treated as manufacturer-reported assertions validated with references on the product specification sheet or supplemental literature.

Table 15: Driver and Integral Controller or Sensor Type Descriptions

Driver and Integral Controller or Sensor Type		Definition	Acceptable Terms on the Product Specification Sheet or Supplemental Literature
WIRED	10V (Wired)	Wired analog low-voltage control that varies DC voltage between 0 and 10 volts (or 1 and 10 volts) to produce varying light output.	0-10 V, 1-10 V, 10V
	BACnet	A communication protocol for building automation and control networks that uses the ISO 16484-5 standards protocol.	BACnet
	D4i	An extension of the DALI-2 standard intended for use within luminaires. D4i control devices include requirements for power and control, to simplify selection of up to two devices for use on a D4i luminaire.	D4i
	DALI	A standard protocol for bi-directional digital communication between lighting control devices. Developed and maintained by the Dali Alliance. The US standard is C137.4 and is maintained by NEMA.	DALI, DALI version-1, Digital Addressable Lighting Interface
	DALI-2	The certification program based on the latest version of the DALI protocol. DALI-2 certification is created and maintained by the DALI Alliance. The US standard is C137.4 and is maintained by NEMA.	DALI-2
	DMX512	Lighting control protocol initially created for use in theatrical installations but in common use in architectural lighting installations where color changing or tuning effects are desired. It describes a method of digital data transmission between a controller and a dimmer or relay panel, or to DMX512-compatible luminaires. Wiring is Class 2 and is required to be a daisy-chain configuration.	DMX512, Digital Multiplex
	Modbus	A client/server data communications protocol developed and maintained by the Modbus Organization. Commonly used in industrial applications.	Modbus



Driver and Integral Controller or Sensor Type		Definition	Acceptable Terms on the Product Specification Sheet or Supplemental Literature
	KNX	A peer-to-peer communication standard used for building automation. Developed and maintained by knx.org	KNX
	Other Analog (Proprietary)	A closed wired analog communication protocol as specified by the manufacturer.	N/A
	Other Digital (Proprietary)	A closed wired digital communication protocol as specified by the manufacturer.	N/A
	Power Over Ethernet	A specific subset of DC products that comply with the IEEE 802.3 Standards for carrying both power and communication signals on Ethernet cables.	PoE, POE
	Phase-Cut	Modification, or cutting, of the leading or trailing edge of the AC mains sinusoidal waveform to produce varying light output.	Phase-cut, phase, forward phase, leading edge, reverse phase, trailing edge, TRIAC, magnetic low-voltage (MLV), electronic low-voltage (ELV)
	Integrated Driver + Controller	A driver and networked controller device where both functions are contained within the same luminaire component housing.	Integrated Driver + Controller
	Dip Switch or Dial	Controllers or sensor mounted features that allow for adjustment of parameters only while the user is physically located at the device	Dip Switches, Dials
WIRELESS	4G Cellular	Fourth Generation cellular network designed to support all-IP communications and broadband services. Developed by the International Telecommunication Union.	4G, 4G LTE
	5G Cellular	Fifth Generation cellular network designed to support all-IP communications and broadband services. Developed by the International Telecommunication Union.	5G
	Bluetooth (Proprietary)	Wireless digital communication protocol developed and maintained by the Bluetooth Special Interest Group (SIG). Uses short-range RF to communicate with other nearby Bluetooth-enabled devices.	Bluetooth, Bluetooth Low Energy, BLE, BLE Mesh

Driver and Integral Controller or Sensor Type	Definition	Acceptable Terms on the Product Specification Sheet or Supplemental Literature
	Bluetooth NLC Wireless digital communication protocol developed and maintained by the Bluetooth Special Interest Group (SIG) specifically for Networked Lighting Control systems. Uses short-range RF to communicate with other nearby Bluetooth-enabled devices.	Bluetooth NLC
	DALI+ DALI+ is the certification program for the wireless or IP-based version of DALI. DALI+ with Thread is the first implementation, using Thread’s low-power IP-based, wireless mesh networking protocol. The US standard is C137.4 and is maintained by NEMA.	DALI+ with Thread
	EnOcean Wireless digital communication protocol developed and maintained by the EnOcean Alliance and based on the ISO/IEC 14543-3-10/11 standard. Geared to wireless sensors and wireless sensor networks with ultra-low power consumption that utilize energy harvesting technology.	EnOcean, Enocean
	Infrared Remote A device which uses infrared radiation to communicate with and program standalone sensors. Usually limited to one-way communication.	IR, Infrared Remote
	Other (Proprietary) A closed wireless communication protocol as specified by the manufacturer.	N/A
	TALQ An open communication standard aimed at smart city applications, including for uses beyond lighting.	TALQ
	Wi-Fi A wireless protocol similar to the protocols that computers use and is a very robust wireless option. It also functions similarly to PoE in that it assigns IP addresses to each device and luminaire and is dependent on the user interface for granularity of dimming range.	Wi-Fi, Wireless Internet
	Zigbee (proprietary) Low-power wireless protocol. It uses an IP address for devices, has a parallel full-duplex communication, and uses short-to medium-range RF to communicate.	ZigBee, ZigBee HA, ZigBee 3.0

Driver and Integral Controller or Sensor Type		Definition	Acceptable Terms on the Product Specification Sheet or Supplemental Literature
		Networked Lighting Control systems with this designation typically do not allow third-party devices.	
	FALO (Lamps Only)	Field Adjustable Light Output allowed for lamps only.	As indicated by the Manufacturer

5.10 Documentation Requirements

Given the rapidly evolving technical capabilities included in the controllability requirements, the DLC review staff will not evaluate any controllability claims against actual performance. Reviewers of product applications will rely on manufacturer claims represented directly on the product specification sheet or supplemental controls documentation (where applicable). Documentation shall have explicit declaration of a capability, along with any ordering information (e.g., model number or ordering code variants) that are associated with the specific capability or attribute.

Products that include twistlock receptacles or sensors/controls installed in a twistlock receptacle will receive additional scrutiny to ensure that variations with 3-pin twistlock receptacles are appropriately evaluated per section 5.4.1

The DLC will monitor its stakeholders’ experience with QPL controllability information and intends to use surveillance testing procedures to address any concerns about controllability performance claims not matching QPL or market available data.



6 Additional Documentation Requirements

6.1 Introduction

The SSL V6.0 technical requirements underpin the Solid-State Lighting Qualified Products List (SSL QPL), which is the primary tool most energy efficiency programs in North America use to validate lighting incentives. Product characteristics not related to performance can be valuable information for QPL users. Thus, Additional Documentation Requirements is a new section in SSL V6.0, making it easier to find product listings and match them to information submitted on incentive applications.

The requirements in this section (images, spec sheets, field adjustability tables and controls options tables) are intended to provide additional information that can facilitate fast incentive application turnaround times, which will, in turn, reduce the overall project timeline.

6.2 Required Product Images

All listed products are required to provide or select a representative image of the qualifying product. Manufacturers may submit their own image, which may be an image of the product or a representative image from the product family. The DLC will also provide a generic image library from which manufacturers may select an image to represent each product or a representative image of the product family. Products using a generic image will be clearly noted and display a disclaimer that states that the image is only representative and QPL users should consult the manufacturer website to view an actual image. The following file requirements and image style guidelines are provided for all manufacturer-provided product images:

6.2.1 File Requirements

- The image file must be in TIFF, GIF, PNG, or JPG format.
- The dimensions of the image must be at least 500 x 500 pixels.
- The image must be square (the width and height of the image must be equal).
- The resolution of the image must be at least 72 ppi (pixels per inch).

6.2.1.1 Image Style Guidelines

- The image must be a photograph or photorealistic rendering; drawings or illustrations of products are not allowed.
- The product image should be the product's professional image or an image commonly used for marketing purposes, if available.

- The product image must have photorealistic color; greyscale images are not allowed. Minimal photo editing necessary to produce a clean, professional image is not considered digital alteration (e.g., removing the background, glare, shadows).
- The background of the image should be white in most circumstances. If a white background inhibits the ability to clearly see the product in the image, the background must be a single shade from within the greyscale range. The product must have smooth edges if the background has been digitally removed.
- The image must not contain confusing or gratuitous objects (for example, hands, signage, items that are not the product).
- The image must not contain additional graphics, inset images, or overlaid text.
- The photo should be professionally lit whenever possible and shot in proper focus. Products must occupy the majority of the available space in the image frame ($\geq 85\%$) and must be framed such that the image clearly conveys the general form of the product. Exceptions will be made for products whose form factor does not allow for the entire product to be in frame or for the product to occupy 85% of the frame.
- Each qualified product may be represented by only one image, including products where aesthetic options are represented in the model number via bracketing or wildcarding. A disclaimer will note that product images may be representative of a single SKU represented by a broader model number.

6.3 Product Specification Sheets

Specification sheets representing all product variations submitted will be publicly displayed on the QPL, and submitters may update the specification sheet after initial qualification. Submitters can select one of two submission pathways for providing specification sheets and are not required to use the same pathway for all products:

1. **DLC-hosted document:** Submitters may choose to display the specification sheet submitted during the application process. The document will be hosted by the DLC and will be available to view on the QPL. After the product is published, submitters may use the DLC portal to update their publicly facing specification sheets. Updated documents must remain consistent with the product information provided to the DLC. The DLC reserves the right to review and deny updated documents as necessary.
2. **Externally hosted document:** Submitters may provide a link to a specification sheet hosted on their own product website, or a product web page where specification sheets are available. Specification sheets may be updated after qualification, but submitters will be responsible for ensuring that the DLC has the correct link, and that updated documents remain consistent with the product information provided to the DLC. The DLC will periodically check that links remain operational and will notify submitters if their link is no longer correct.

The QPL will display the date on which specification sheets were updated. The DLC reserves the right to periodically review updated specification sheets to ensure product integrity.

6.3.1 Specification Sheet Document Requirements

The DLC does not dictate the style or layout of specification sheets. The following requirements are necessary for the DLC to accurately review and link to specification sheets on the QPL.

- Must be in PDF format
- Must include the following:
 - Manufacturer name or brand name
 - Product model number
 - Information pertaining to Section [5.6 Dimming Requirements](#)
- Specification sheets must also include product or program-specific requirements as applicable. The following sections are listed for reference and contain additional details related to the content of specification sheets:
 - [5.4 Controls Ready \(Controls Category 1\)](#)
 - [5.5 Controls Options Tables](#)
 - [5.7 Special Controllability Considerations for Dimmable Lamps](#)
 - [5.8 5.8 Integral Controls](#)
 - [11.2.1 Reporting and Documentation Requirements: Sustainability](#)
 - [15.3 LUNA Light Distribution Requirements](#)
 - [15.6 LUNA Turtle Lighting PUD Requirements](#)
 - [15.8.1 Documentation Requirements for LUNA Efficacy Allowances](#)
 - [16.2 Field Adjustable Color Temperature \(FACT\)](#)
 - [16.3 Field Adjustable Light Output \(FALO\)](#)
 - [16.4 Field Adjustable Light Distribution \(FALD\)](#)
 - [16.5 Supporting Documentation](#)
 - [17.5 Supporting Documentation for Color-Tunable Products](#)
 - [19.2 Special Considerations for Solar Powered Outdoor Luminaires](#)
 - [22.3 Luminaire Level Tests](#)
 - [23.2 Testing and Reporting Requirements for Retrofit Kits](#)
 - [24.2.7 Minimum Testing Requirements: LUNA Distribution](#)
 - [26 Testing and Reporting Requirements for Alternate LEDs and Drivers](#)
 - [27.2 ANSI/IES LM-79 \(-19 and -24 Versions\)](#)



7 Lumen Maintenance

7.1 Introduction

Maintaining the expected performance over a product’s lifetime is critical for energy efficiency programs to realize expected savings and for end user satisfaction. To ensure persistent performance, all SSL/LUNA QPL products must meet minimum lumen maintenance requirements under SSL V6.0 and LUNA V2.0. These technical requirements also encourage the use of the latest industry standards by including optional pathways for reporting in-situ temperature measurement testing (ISTMT) per ANSI/IES TM-41-24 and set a lower L₇₀ criterion for non-white light.

7.2 Lumen Maintenance

The DLC expects manufacturers to provide the most up-to-date LM-80 report available for the LED package, module, or array used within the product. It is the submitting manufacturer’s responsibility to ensure that they have received the most up-to-date LM-80 report from the LED manufacturer for each application. Additional data that improves projection accuracy may not be ignored simply because it shows worse performance.

The Lumen Maintenance requirements for DLC Standard are shown in [Table 16](#).

Table 16: Lumen Maintenance Requirements for DLC Standard

Metric	Applicable Products	DLC Standard	Method of Evaluation
Lumen Maintenance	All products of 2200 K – 6500 K, including Filtered Amber products	L ₇₀ ≥ 50,000 hours	LM-80 and TM-21 ISTMT and LM-98-24 report OR
	All NWL products except for Filtered Amber	L ₇₀ ≥ 36,000 hours	LM-84 and TM-28

The DLC provides two options for demonstrating lumen maintenance compliance.

- Lumen Maintenance Option 1:** Using component-level performance through the ANSI/IES TM-21 protocols, which leverage the LM-80 performance and in-situ temperature of the LED device.
- Lumen Maintenance Option 2:** Using luminaire-level performance through ANSI/IES TM-28 protocols, which leverage the ANSI/IES LM-84-20 test performance. More information is available in the [Application Instructions](#). *Note:* Due to the length of this type of testing, it is recommended that the submitter reach out to applications@designlights.org to ensure that the testing will align with DLC Testing and Reporting Requirements before beginning any testing using the LM-84-20 method.



8 Power Quality

8.1 Introduction

Baseline power quality performance—measured by total harmonic distortion (THD) in current and power factor—is critical for utilities because it directly impacts grid stability, system efficiency, and equipment longevity. Maintaining these parameters within industry standards minimizes losses, reduces wear on infrastructure, and enables reliable integration of renewable and distributed energy resources.

Requirements in this section are unchanged from SSL V5.1.

8.2 Power Factor and Total Harmonic Distortion (THD)

All DLC-qualified luminaires (Standard, Premium, LUNA) must have a power factor of at least 0.9 and a THD of 20% or less. Qualifying products must meet the requirements in their worst-case loading conditions. (For information on minimum required testing, see [Minimum Testing Requirements: Power Quality](#).)



9 Safety

9.1 Introduction

Safety certifications provide independent verification that QPL listed products comply with established codes and industry standards, thereby mitigating operational and electrical hazards and helping ensure that products incentivized by utilities avoid costly liabilities.

Requirements in this section are unchanged from SSL V5.1.

9.2 Original Equipment Manufacturer (OEM) Safety Certification Testing and Reporting Requirements

The DLC relies on the submitting manufacturer and the organization issuing the safety certification to determine the appropriate standard to evaluate the product. Products must be certified to the applicable safety standard by a safety certification organization relevant in the United States or Canada. In the United States, this means [a safety certification body recognized by OSHA](#). In Canada, this means [a certification body recognized by the Standards Council of Canada](#). The scope of accreditation must include certification of lighting products.

The DLC will perform a limited review of the safety documentation submitted by the manufacturer. It is the responsibility of the applicant to verify that ALL of the model numbers submitted for qualification are covered by the safety certification documents. If the submitted model numbers are found to not have been covered by the safety certification documents that were originally submitted, the models will be removed from the QPL, and further action may be taken, if necessary.

If, after qualification, the safety documentation gets updated so that any model number(s) listed on the QPL are no longer covered by the original safety certificate, it is the responsibility of the manufacturer to submit the revised documentation to the DLC so that the DLC records can be updated accordingly. Failure to do so may result in the product and any associated family members being delisted.

- **Compliance Certificate:** A compliance certificate from an approved safety certification organization relevant in the United States or Canada (see **Part VI**) must be submitted for all products. This compliance document shall bear the manufacturer's name and will be proof that the products listed have been investigated by the safety organization and found to be in compliance with the standards listed on the certificate. The name of this document varies by safety organization; however, it is commonly referred to as a Certificate of Compliance or an Authorization to Mark. Examples of appropriate documents from specific safety organizations:
 - Intertek – Authorization to Mark
 - UL – Certificate of Compliance or Notice of Authorization
 - CSA – Certificate of Compliance.



10 Warranty

10.1 Introduction

Warranties provide formal assurance for utilities and their customers that products will perform to specified standards over a defined period of time, thereby reducing financial and operational risks associated with premature failure.

Requirements in this section are unchanged from SSL V5.1.

10.2 Warranty Requirements

The DLC requires a minimum warranty period of five years on all products listed on the QPL. The warranty must cover the complete luminaire, retrofit kit, or replacement lamp when applicable. It is important to note that the “luminaire” includes light source, housing, heat sink, power supplies, and other electrical components, optics, and any other components of the luminaire. Warranty documentation must clearly explain the terms and conditions associated with the warranty.

Warranties that only cover certain components of the luminaire, retrofit kit, or replacement lamp are not sufficient to meet the requirement. Consumable components that are designed and intended to be replaced as part of regular maintenance and upkeep, such as air filter elements or UV-C lamps, are not subject to the warranty requirements. Warranty statements are reviewed on a case-by-case basis, and the DLC reserves the right to seek additional clarification if necessary.

Warranty terms and conditions can vary widely from manufacturer to manufacturer. The DLC explicitly calls for a warranty period of five years and does not have specific requirements for warranty claim terms other than those listed above. The DLC does not verify or validate a manufacturer’s terms, conditions, or process for customer warranty claims. The DLC does not monitor field failure rates of qualified products, policy regarding warranty redemption, or warranty redemption history among manufacturers. Industry stakeholders are urged to review warranty terms and conditions as part of the purchasing decision process.



11 Sustainability

11.1 Introduction

Environmental considerations, such as carbon reduction and material health, extend beyond energy efficiency. The SSL V6.0 metrics and QPL data focus on a product’s use phase, assessing impacts such as energy consumption, light pollution, and other environmental factors from installation to removal. To support demand for sustainable lifecycle practices in the lighting industry, the optionally reported data in this section informs impacts from additional lifecycle stages and offers a comprehensive view of a product’s total environmental impact. This includes any aspects in a lifecycle assessment (LCA) beyond the use phase. By encouraging manufacturers to disclose lifecycle data, the DLC aims to support broader sustainability efforts in lighting and showcase opportunities beyond energy savings alone.

11.2 Sustainability Reporting Options

SSL V6.0 and LUNA V2.0 add an optional reported field for third-party verified green labels, certifications, and environmental product declarations (EPDs). Sustainability certifications and documents available for reporting are listed in [Table 17](#), along with materials required for verification in the “Method of Evaluation” column. The DLC reserves the right to request additional documentation for verification as needed.

Table 17: Optionally Reported Sustainability Fields

Certification Body or Organization	Certification Level	Method of Evaluation
Environmental Product Declaration (EPD)	ISO 14025 compliant	EPD document (must be registered with an EPD program operator)
Declare	Declared	Declare Label
	Red List Approved	
	Red List Free	
Restriction of Hazardous Substances in Electrical and Electronic Equipment (RoHS)	RoHS Compliant	Product documentation with RoHS label or RoHS Declaration of Conformity
	RoHS 2	
	RoHS 3	
Lighting for Good	Fair	Product documentation with Lighting for Good label
	Good	
	Best	
Cradle to Cradle	Bronze	Product documentation with C2C label or C2C Certification document
	Silver	
	Gold	
	Platinum	
UL GREENGUARD	GREENGUARD Certified	Product documentation with GREENGUARD label or GREENGUARD Certification document
	GREENGUARD Gold	
TÜV Rheinland	Green Product Mark	Product documentation with Green Product Mark or Green Product Mark Certificate

11.2.1 Reporting and Documentation Requirements: Sustainability

For all certifications that allow product documentation with a label as a verification method in the Method of Evaluation Column above, the provided specification sheet or supporting documentation will be reviewed for the label or logo that confirms compliance with the associated certification. If a different method of evaluation is used, sensitive information may be redacted, and the DLC reserves the right to request additional information as needed. Submitters are responsible for keeping sustainability information up to date. If the status of a certification changes (i.e., the certification expires and is not renewed), the submitter must update the listing to reflect this change. Certification renewals do not

need to be reported to the DLC, as long as the certification status remains the same. The DLC will periodically review listed products to ensure that the sustainability information remains accurate. If a product is found to have incorrect information, the submitter will be notified, and the certification will be removed from the QPL listing until the DLC receives updated information.

11.2.2 QPL Listing: Sustainability

The names of all reported certifications and certification levels will appear on the QPL. This will not include any information contained in the documents provided for review or links to online databases. The QPL listing should reflect the current status of each certification listed.



12 Efficacy Allowances

12.1 Introduction

As with previous revisions of the DLC Technical Requirements, the SSL V6.0 and LUNA 2.0 revision includes increases in efficacy thresholds. To realize long-term energy savings, quality must go hand-in-hand with efficacy. The DLC recognizes the risk that some products may achieve higher efficacy at the expense of quality, which can leave customers unsatisfied and/or can negatively impact human health or well-being. This version incorporates quality requirements to ensure that the QPL includes a balance of products that provide good quality of light, while at the same time saving energy through high efficacy and controllability.

The intent of the *Efficacy* requirements is not to drive market development or customer choice away from features that contribute to the overall quality of light, or the quality of the lighting for a particular space. SSL V6.0 grants allowances to efficacy requirements, applicable to both tested and reported performance values, to offset potential efficacy tradeoffs due to these enhanced quality features.

LUNA V2.0 Technical Requirements provides additional allowances specific to LUNA qualified products.

12.2 Efficacy Allowances

Efficacy allowances are provided for products with improved color rendition, products with CCT ≤ 2700 K, and certain indoor luminaire and integrated retrofit kit PUDs with low UGR values. Allowances for efficacy thresholds are summarized *Table 18*.

Efficacy allowances are cumulative up to a maximum allowance of 15%, except for NWL products, which may have a cumulative allowance up to 25%. Additionally, a product may take advantage of an efficacy allowance in conjunction with the luminaire efficacy tolerance, as stated in Table 19.

Table 18: Efficacy Allowances

Feature	Category or General Application	Performance Metric	Allowance Percentage	Method of Evaluation
Low CCT	All Products Within Standardized CCT Quadrangles	≤2700 K	-8%	Same as V6.0 Standard
		≤2200 K	-10%	
		≤2000 K	-20%	
		≤1800 K	-25%	



Feature	Category or General Application	Performance Metric	Allowance Percentage	Method of Evaluation
High Color Rendition	All Indoor products (except high-bay and NWL) including linear replacement lamps and replacements for CFLs	Option 1 - ANSI/IES TM-30: <ul style="list-style-type: none"> • IES $R_f \geq 75$ • IES $R_g \geq 92$ • $-7\% \leq \text{IES } R_{cs,h1} \leq +19\%$ Option 2 - CIE 13.3-1995: <ul style="list-style-type: none"> • $R_a \text{ (CRI)} \geq 90$ and $R_9 \geq 50$ 	-5%	Same as V6.0 Standard
		ANSI/IES TM-30: <ul style="list-style-type: none"> • IES $R_f \geq 78$ • IES $R_g \geq 95$ • $-1\% \leq \text{IES } R_{cs,h1} \leq +15\%$ 	-10%	
	All Outdoor (except NWL), including Omnidirectional /Directional E26 and E39 lamps, and high-bay products	Option 1 - ANSI/IES TM-30: <ul style="list-style-type: none"> • IES $R_f \geq 70$ • IES $R_g \geq 89$ • $-12\% \leq \text{IES } R_{cs,h1} \leq +23\%$ Option 2 - CIE 13.3-1995: <ul style="list-style-type: none"> • $R_a \text{ (CRI)} \geq 80$ and $R_9 \geq 0$ 	-5%	
Enhanced Discomfort Glare Control	Troffer (Luminaires and Integrated Retrofit Kits only)	Corrected UGR < 16.0	-10%	Corrected UGR values generated per CIE 190-2010 at the following reference condition: <ul style="list-style-type: none"> • Room dimensions: X = 4H, Y = 8H • Spacing to height ratio (S/H): 1 • Reflectances: 70/50/20
	Linear Ambient, (Luminaires and Retrofit Kits only)	Corrected UGR < 16.0	-10%	
	Low-Bay (Luminaires and Retrofit Kits only)	Corrected UGR < 19.0	-10%	
	High-Bay, (Luminaires and Retrofit Kits only)	Corrected UGR < 22.0	-10%	

12.2.1 Testing Requirements for Efficacy Allowances

Information on minimum required testing is provided in the following sections: *Minimum Testing Requirements: Spectral Quality for Efficacy Allowances* and *Minimum Testing Requirements: Discomfort Glare Efficacy Allowances*.

12.2.2 Interactions With Other DLC Policies: Field Adjustable Light Distribution

Field Adjustable Light Distribution (FALD) products are eligible for efficacy allowances, including allowances related to discomfort glare per the PUD performance metric requirements given in *Table 18: Efficacy Allowances* (see **Section 12.2**). The *Minimum Testing Requirements: DLC Standard Light Output and Distribution* for UGR are applicable to FALD products.



13 Tolerances

13.1 Introduction

Tolerances are established to account for minor, acceptable deviations between measured test data and minimum threshold values for qualifications. Deviations may arise from recognized sources such as measurement uncertainty or manufacturing variability. These tolerances are applied solely in evaluating test results against DLC performance thresholds.

13.2 Tolerances

The DLC accepts measurement tolerances for most metrics listed in this document, as described in [Table 19](#).

For nominal value performance metrics, tolerance is a percentage of the required value. Reported data is considered the nominal performance and must meet the minimum technical requirements without a tolerance applied. All products must have a nominal performance at or exceeding the minimum DLC threshold without a tolerance, even tested products whose performance is below the DLC performance threshold but within the tolerance range. While test labs will be expected to follow the requirements of their accreditation and relevant test standards, DLC staff will not employ additional “rounding” to interpret values beyond the absolute thresholds as passing. For example, for a minimum efficacy requirement of 110 lm/W with a -3% tolerance, the functional requirement for tested data of a product with nominal performance of 110 lm/W is 106.7 lm/W (i.e., $110 \times 97\% = 106.7$). (For zonal lumen tolerances specific to each Primary Use Designation, please refer to [Light Distribution](#).)

Table 19: Tolerances

Performance Metric	Product Type	Tolerance
Light Output	All	±10%
Luminaire Efficacy	All	-3%
Color Rendition	All	CIE R_a (CRI): -1 Point CIE R_9 : -1 Point IES R_f : -1 Point IES R_g : -1 Point IES $R_{cs,h1}$: +/- 1%
Color Maintenance	All	$\Delta u'v'$: +0.0004 points*
Power Factor	All	-3 percentage points
Total Harmonic Distortion	All	+5 percentage points
Beam Angle	Medium screw-base, Mogul screw-base, Linear replacement lamps, 2G11 lamps	-5°
Dominant Wavelength	de-Amber, pc-Amber	+ 10 nm
Full-Width Half-Maximum (FWHM)	de-Amber, pc-Amber	+/- 10 nm

* Table note: Data must be consistent with the LM-80 testing and reporting guidelines.

13.2.1 Reporting and Implementation Details

The requirement values and tolerances will be interpreted by DLC review staff as exact requirements. While test labs will be expected to follow the requirements of their accreditation and relevant test standards, DLC staff will not employ additional rounding to interpret values below the absolute thresholds as passing. For example, if a luminaire is required to have an efficacy of 110 lm/W, then with the efficacy tolerance of -3%, any value for efficacy less than 106.70 will be interpreted as a failing value. It is the applicant's responsibility to check all data presented in an application before submission to ensure compliance with the DLC requirements.



Part III: Requirements for DLC Premium

Part III sets an enhanced focus on the DLC pillars: efficacy, quality of light, and controllability. DLC Premium builds on DLC Standard requirements and sets higher thresholds and performance requirements than those of DLC Standard, to distinguish the top-performing products in terms of efficacy, quality of light, and controllability.



14 DLC Premium

14.1 Introduction

With advanced controls capabilities, modern LED luminaires enable deeper integration with building systems for maximum energy savings and flexible energy use. As utilities provide more electricity to meet demand, luminaires with advanced controls are becoming more important in helping manage loads. As such, the Premium classification has transformed to focus on these capabilities along with efficacy, lifetime, and quality of light. LED products combining higher efficacy with advanced control strategies deliver the right amount of light at the right time while using fewer watts, which translates into lower energy consumption and greater operational savings over time. The Premium classification ensures that products meet the most rigorous standards for efficacy, controllability, and performance, providing both enhanced energy efficiency and long-term reliability. These criteria include improved lumen maintenance, thermal management, and driver durability, all of which contribute to reduced maintenance costs and extended luminaire lifespans.

In addition, advanced color control requirements help minimize visual inconsistencies between luminaires, ensuring a uniform and professional lighting appearance throughout a space. Reduced discomfort from glare, especially from recessed troffers, enhances the occupant experience by creating more comfortable and visually balanced environments that are ideal for commercial and industrial settings.

Ultimately, these features combine to deliver a high-quality lighting solution that supports sustainability goals, enhances visual performance, and lowers the total cost of ownership.

This version of the technical requirements maintain UGR requirements for Troffer PUDs and remove UGR requirements for Linear Ambient, High-Bay, and Low-Bay PUDs.

14.2 Premium Eligibility

Products submitted for DLC Premium qualification must meet more stringent efficacy requirements, as outlined in [Table 20](#) and other Premium requirements for quality, controllability, and lifetime as outlined in [Table 21](#). DLC Premium products are eligible for LUNA qualification. (See [Section 15 LUNA V2.0 Technical Requirements](#).)

The following product types are not eligible to qualify for the DLC Premium qualification:

- Replacement lamps
- Linear-Style Retrofit Kits for 2x2, 1x4, and 2x4 Luminaires
- Products with a Primary Use designated as “Specialty”
- NWL products: de-Amber, pc-Amber, Filtered Amber, and 1800 K – 2000 K

14.3 Driver Lifetime

To demonstrate compliance with the driver lifetime requirements, manufacturers must provide the following for all DLC Premium listings:

- A test report from a lab that meets the [DLC's Laboratory Requirements](#) for ISTMTs. The report must include the measured temperature from the TMP_{ps} . The DLC encourages the use of the latest industry standards and allows reporting of ISTMT reports in accordance with LM-98-24.
- UL 1598 testing may be used for the ISTMT report if the lab that conducted the test meets the DLC's laboratory requirements for ISTMT.
- A photograph of the TMP_{ps} location with an arrow indicating the thermocouple attachment point.
- Documentation from the driver manufacturer detailing the maximum case temperature for which the driver is designed, as well as the TMP location it designates for thermal testing.
- For custom and integrated drivers: documentation equivalent to that required for drivers from third-party vendors. Manufacturers must supply documentation indicating the maximum acceptable temperature for the driver to meet driver lifetime requirements, as well as the TMP to be used during thermal testing and evaluation.

The luminaire passes the driver lifetime requirements if the measured temperature at the TMP_{ps} is less than or equal to the allowable operating temperature for which the driver is designed to last at least as long as the lifetime threshold specified by the power supply manufacturer. Drivers shall be tested in-situ under steady-state operating conditions, with case temperature measured at the designated TMP.

One or more additional thermocouples are attached to the power supply or driver at the TMP_{ps} . For off-the-shelf remote power supplies, manufacturers typically provide a measurement location (case temperature designated by a "dot" adjacent to a (t_c) symbol) for warranty and/or lifetime purposes. In situations where the TMP_{ps} is not designated by the manufacturer, or where power supplies are integrated with the LED package(s), array, or module(s), luminaire manufacturers should identify the TMP_{ps} to be used for warranty and/or lifetime purposes. It is important to note that this includes situations where the driver or power supply is not purchased from an outside vendor, and where the driver or power supply is integrated into the luminaire or lamp.

The thermocouple tolerance shall conform to ASTM E230 Table 1 "Special Limits" ($\leq 1.1^{\circ}C$ or 0.4%, whichever is greater).

Driver specification sheet documentation provided for custom and integrated drivers must be equivalent to that from third-party vendors. This also applies to private labeled drivers where the private labeler does not market the driver and therefore does not have a public-facing driver specification sheet for it. Equivalent driver specification sheet documentation must include information on the rated driver performance, including but not limited to input and output characteristics, the maximum case temperature for which the driver is designed to last at least 50,000 hours, and the specific driver model number. DLC reviewers may ask for additional driver information.

14.4 Premium Requirements

Table 20: DLC Premium Efficacy Requirements

Category	General Application	Primary Use Designation	DLC Premium Minimum Efficacy (lm/W)
Outdoor Luminaires and Solar Powered Outdoor Luminaires	Note: Light Output requirements vary by General Application type (e.g. Low, Mid, High and Very High Output) See Table 5	Outdoor Pole/Arm-Mounted Area and Roadway Luminaires	140
		Outdoor Pole/Arm-Mounted Decorative Luminaires	130
		Outdoor Zero-Uplight Wall-Mounted Area Luminaires	140
		Outdoor Uplight-Emitting Wall-Mounted Area Luminaires	140
		Bollards	130
		Parking Garage Luminaires	130
		Fuel Pump Canopy Luminaires	140
		Architectural Flood and Spot Luminaires	140
		Stairwell and Passageway	140
		Sports Lighting	130
		Hazardous Environment Area Luminaires	130
Indoor Luminaires	Interior Directional	All	110
	Case Lighting		120
	Troffer		135
	Linear Ambient		140
	High-Bay	All except Hazardous Environment High-Bay Luminaires	150
		Hazardous Environment High-Bay Luminaires	145

	Low-Bay	All except Hazardous Environment Low-Bay Luminaires	145
		Hazardous Environment Low-Bay Luminaires	140
Outdoor Retrofit Kits	Note: Light Output requirements vary by General Application type (e.g. Low, Mid, High and Very High Output) See Table 5	Retrofit Kits for Outdoor Pole/Arm-Mounted Area and Roadway Luminaires	140
		Retrofit Kits for Outdoor Pole/Arm-Mounted Decorative Luminaires	130
		Retrofit Kits for Large Outdoor Pole/Arm-Mounted Area and Roadway Luminaires	140
		Retrofit Kits for Outdoor Zero-Uplight Wall-Mounted Area Luminaires	140
		Retrofit Kits for Parking Garage Luminaires	130
		Retrofit Kits for Fuel Pump Canopy Luminaires	140
Indoor Retrofit Kits	Troffer	All	135*
	Linear Ambient		140
	High-Bay		150
	Low-Bay		145

* *Table note:* Linear-style retrofit kits for 2x2, 1x4, and 2x4 luminaires are not eligible for DLC Premium

Table 21: DLC Premium Testing and Reporting Requirements

Metric	Applicable Product(s)	SSL V6.0 & LUNA V2.0 Premium Requirements*	Method of Evaluation
Chromaticity (CCT & D_{uv})	All Indoor products, except High-Bay	Products shall exhibit chromaticity consistent with at least one of the basic, flexible, or extended nominal 4-step quadrangle CCTs from 2200 K – 6500 K	Same as V6.0 Standard
	High-Bay products	Products shall exhibit chromaticity consistent with at least one of the basic, flexible, or extended nominal 7-step quadrangle CCTs from 2200 K – 6500 K	
	All outdoor, except Sports Lighting and Fuel Pump Canopy	Products shall exhibit chromaticity consistent with at least one of the basic, flexible, or extended nominal 7-step quadrangle CCTs from 2200 K – 5000 K	
	Sports Lighting and Fuel Pump Canopy	Products shall exhibit chromaticity consistent with at least one of the basic, flexible, or extended nominal 7-step quadrangle CCTs from 2200 K – 5700 K	
Discomfort Glare	Troffer (Luminaire and Integrated Retrofit Kits only)	Corrected UGR < 22.0	Corrected UGR values generated per CIE 190-2010 at the following reference condition: Room dimensions: X = 4H, Y = 8H Spacing to height ratio (S/H): 1 Reflectances: 70/50/20
Controllability	All products	<ul style="list-style-type: none"> Must be capable of continuous dimming down to 10% of initial output or lower. Must meet requirements for any controls category excluding Category 0 	Same as V6.0 Standard
Lumen Maintenance	All products	(In addition to L ₇₀ thresholds) L ₉₀ ≥ 36,000 hours	Same as V6.0 Standard
Driver Lifetime	All products	≥50,000 hours	

* Table note: For any metric not listed in this table, V6.0 Standard requirements apply.

For information on minimum required testing, see [Minimum Testing Requirements: Spectral Quality for Efficacy Allowances](#) and Minimum Testing Requirements: DLC Premium Light Distribution.

14.4.1 UGR Requirements for Indoor Products

Performance requirements related to discomfort glare in SSL V6.0 are calculated with the Unified Glare Rating (UGR) metric and only apply to products seeking [DLC Premium](#) qualification that meet the given UGR thresholds in Table 21 and/or to products seeking [Efficacy Allowances](#) that meet the given UGR thresholds in [Table 18](#). UGR defined in [CIE 117-1995](#) is a metric for evaluating discomfort from glare of certain products in the Indoor category. UGR for an array of one type of luminaires in a set of reference conditions can be determined using the procedure described in [CIE 190-2010](#). This is known as the tabular method and is widely used in Europe and other regions. Maximum UGR requirements apply only to Troffer PUDs.



Part IV: Requirements for LUNA V2.0

Dedicated to DLC's LUNA program, Part IV specifies LUNA V2.0 requirements that support responsible outdoor lighting practices and mitigate light pollution. To achieve these goals, LUNA V2.0 stipulates additional spectral, light output, and distribution requirements beyond those provided in the Standard, Premium, or Amber parts/sections. Standard classified, Premium classified, and Amber outdoor products are eligible to qualify for LUNA V2.0 if they meet the additional testing and reporting requirements in this part.



15 LUNA V2.0 Technical Requirements

15.1 Introduction

The LUNA V2.0 Technical Requirements continue to serve the DLC’s mission to address the growing issue of light pollution. Light pollution disrupts the circadian rhythms of humans and animals; disorients turtles, birds, and insects; and separates people from the night sky.

LUNA V2.0 expands eligibility to include non-white light (NWL) luminaires, lamps, and retrofit kits (including low CCT, FACT, and amber products), while introducing new turtle lighting PUDs and simplifying controllability requirements to align with SSL V6.0. LUNA V2.0 adds S/P ratio reporting and indicates product compliance with certain Hawaii county ordinances. Overall, these updates broaden product scope, address coastal and light pollution concerns, and streamline compliance for manufacturers.

To support national, state, and/or local ordinances, regulations, and policies regarding light pollution, LUNA V2.0 continues to use Uplight (U) ratings to set maximum limits on uplight emitted directly by the luminaire. Turtle Lighting PUDs also have an additional requirement for maximum Glare (G) rating to minimize high-angle light. The G rating metric was selected because of its ubiquity as an outdoor lighting performance, and here is used as a proxy metric for limiting the high-angle light emitted from a luminaire; it is not used as a discomfort glare metric for humans or turtles.

Finally, controllability is a priority for LUNA. Sky glow and light trespass can also be reduced with high-end trim, enabling designers to meet design requirements without over-lighting. In addition, light pollution can be reduced by dimming down as far and as frequently as appropriate, including with part-night dim controls, based on lower volumes of traffic and pedestrian conflict at some times of the night. Reducing light output to reduce light pollution also saves energy by delivering illumination when and where it is needed. Continuous dimming also facilitates compliance with energy code requirements for light level reduction, including recent versions of [ASHRAE 90.1](#), [IECC](#), and [California’s Title 24](#).

15.2 LUNA Eligibility and Requirements

Products submitted for DLC LUNA V2.0 qualification must meet more stringent LUNA requirements, as outlined in this section. Table 22 lists the PUDs that are eligible for LUNA V2.0 and their respective Primary Use Letters, maximum U-ratings, and light output. DLC LUNA products are eligible for Premium qualification (see DLC Premium). Solar Powered Outdoor Luminaires are eligible for LUNA (see Solar Powered Outdoor Luminaires).

The following product types are NOT eligible to qualify for LUNA V2.0:

- Indoor products and indoor retrofit kits
- Linear replacement lamps



- Indoor and Outdoor Mogul Screw Base Replacements for HID Lamps that are based on luminaire PUDs
- Four Pin-Base CFL replacement lamps
- Outdoor Uplight-Emitting Wall Mounted Area luminaires
- Parking Garage luminaires
- Architectural Flood and Spot luminaires
- Stairwell and Passageway luminaires
- Sports Lighting
- Products with a Primary Use designated as “Specialty” except those designated in [Table 22](#).

Table 22: PUDs Eligible for LUNA V2.0 Qualification and Respective U Rating Maximums

Primary Use Letter	PUDs Eligible for LUNA Qualification	Maximum U Rating	Maximum Light Output (Lumens)
A	Outdoor Pole/Arm-Mounted Area and Roadway Luminaires	1	N/A
B	Outdoor Pole/Arm-Mounted Decorative Luminaires	2	N/A
C	Outdoor Zero-Uplight Wall-Mounted Area Luminaires	0	N/A
E	Bollards	1	N/A
G	Fuel Pump Canopy Luminaires	2	N/A
Y	Retrofit Kits for Outdoor Pole/Arm-Mounted Area and Roadway Luminaires	1	10,000
Z	Retrofit Kits for Outdoor Pole/Arm-Mounted Decorative Luminaires	2	10,000
AA	Retrofit Kits for Large Outdoor Pole/Arm Mounted Area and Roadway Luminaires	1	10,000
AB	Retrofit Kits for Zero-Uplight Outdoor Wall Mounted Area Luminaires	0	10,000
AD	Retrofit Kits for Fuel Pump Canopy Luminaires	2	10,000



BI	Omnidirectional/Directional Mogul Screw-Base Replacements for HID Lamps (Type B)	N/A	10,000 (bare lamp)
BJ	Omnidirectional/Directional Medium Screw-Base Replacements for HID Lamps (UL Type B)	N/A	10,000 (bare lamp)
BF	Turtle Lighting Zero-Uplight Pole/Arm-Mounted Area and Roadway Luminaires	0	8000
BG	Turtle Lighting Zero-Uplight Wall-Mounted Area Luminaires	0	2500
BH	Turtle Lighting Zero-Uplight Bollards	0	1000
BA	Hazardous Environment Area Luminaires	1	N/A
N/A	Specialty: Hazardous Environment Outdoor Pole/Arm-Mounted Area and Roadway Luminaires	1	N/A
	Specialty: Hazardous Environment Wall Mounted Luminaire	1	N/A
	Specialty: Canopy Lighting	2	N/A
	Specialty: Directional Fuel Pump Canopy Luminaires	2	N/A
	Specialty: Transportation	2	N/A

15.3 LUNA Light Distribution Requirements

This section provides the LUNA V2.0 requirements for light distribution. *Table 23* includes columns for the metric or application, its associated requirements, and its QPL Listing. The “Method of Evaluation” column describes how products will be evaluated for qualification, whether by compliance with industry standards, manufacturer claims, or other DLC verification methodology. (For information on minimum required testing, see *Minimum Testing Requirements: LUNA Distribution.*)

Luminaires with internal or external auxiliary shielding and/or performance optics may improve the quality of the light distribution, helping to ensure that light is only delivered where it is intended, rather

than potentially causing light trespass on neighboring locations. Manufacturers may offer a variety of shielding options such as house-side shields (HSS), cul-de-sac shields (CSS), front-side shields (FSS), left and right shields, and glare shields (See [Table 26](#)).

To attain LUNA qualification for products in the pole/arm-mounted area/roadway/decorative PUD, at least one specifiable shielding option or accessory must be offered on the product specification sheet or in supplemental documentation. The shields may be external to the luminaire or internal to the glass or optic. DLC reviewers will evaluate submitted documentation to ensure that a shield option or accessory is available.

Table 23: LUNA V2.0 Light Distribution Requirements

Metric or Application	LUNA V2.0 Requirements	QPL Listing	Method of Evaluation
Uplight Rating (From the IES BUG Rating system)	<p>Products must have a U rating of 0, 1, or 2, depending on Primary Use Designation indicated in Table 22.</p> <p>ANSI/IES LM-63 IES-format files (and optionally ANSI/IES TM-33-18 or -23 XML documents[†]) containing luminous intensity distribution data must be submitted for a representative LUNA qualifying product for each unique distribution pattern included in the application. (See additional details below.)</p>	<p>BUG ratings for parent products will be generated by the DLC using the tested photometric data provided and will be listed under the Tested Data section. BUG ratings for child products are reported by the applicant and listed under the Reported Data section.</p>	<p>ANSI/IES LM-79 per the Additional Requirements for LM-79, LM-80, and TM-21 Test Reports.</p> <p>BUG ratings generated per Annex A in ANSI/IES TM-15-20 using luminaire photometric data (.ies files).</p> <p><i>Note:</i> For LUNA qualification, LM-79 and distribution testing must be provided on a LUNA-qualifying product (highest light output at highest LUNA-eligible CCT).</p>
Luminous intensity distribution image	<p>Using the LUNA pre-submission tool, the submitter will create a PNG luminous intensity distribution image for the representative LUNA qualifying product for each unique distribution pattern included in the application.</p>	<p>For each distribution parent product, images from the LUNA pre-submission tool will be listed under the Tested Data section.</p>	<p>Submitted Luminous intensity distribution images generated by the LUNA pre-submission tool from the submitted IES files.</p>



Metric or Application	LUNA V2.0 Requirements	QPL Listing	Method of Evaluation
Aiming	Products may only include mounting options that will not allow tilt angles beyond ± 10 degrees, in order to level the luminaire parallel with the roadway surface (see Figure 1).	Model number will include allowed mounting options. Products with mounting accessories are eligible for LUNA and will be listed on the QPL with the mounting accessories that meet all of the technical requirements. Eligible mounting accessories will be listed in parentheses on the QPL.	Specification sheet, supplemental documentation, or installation instructions must include photos or illustrations of mounting options or accessories with allowable tilt angles (and degree values), or fixed mounting options clearly documented, as per Figure 1 .
Shielding	Shielding as an available accessory or option must be included on specification sheets or supplemental documentation (e.g., house side shields (HSS), cul-de-sac shields (CSS), front-side shields (FSS), or glare shields) for pole/arm-mounted area/roadway/decorative PUDs (Primary Use letters A and B), and for specialty hazardous environment pole/arm-mounted area and roadway PUDs.	<p>Specific product configurations without shielding will be listed on the QPL per the LUNA requirements as long as a shield is available as an accessory or option.</p> <p>For those who voluntarily choose to list their shielded products and are seeking efficacy allowances, within each given shielding subgroup, shielded products with the lowest efficacy will be listed as worst-case efficacy parent products on the QPL.</p> <p>Shielded products with the highest house-side lumens for products with a HSS or CSS, or street-side lumens for products with a FSS, will be listed as worst-case distribution parent products on the QPL.</p>	Specification sheet or supplemental documentation review to determine that at least one shielding accessory or option is available.

Metric or Application	LUNA V2.0 Requirements	QPL Listing	Method of Evaluation
Field Adjustable Light Output (FALO)	All LUNA Products with selectable wattage and/or lumen output must be shipped at the lowest wattage or output setting to be LUNA qualified	N/A	Specification sheet, supplemental documentation, or installation instructions

† *Table note:* IES-format data files may be submitted alone without also submitting ANSI/IES TM-33-18 (or -23) XML documents. If XML documents are submitted, IES files must also be submitted so that Photometric Toolbox® can be used by DLC reviewers for evaluation. (See the [LUNA Testing and Reporting Requirements](#) for more information.)

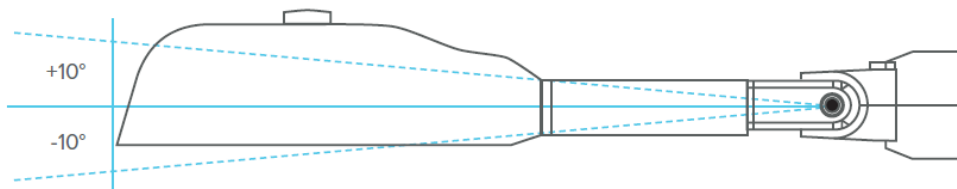

Figure 1: Acceptable maximum mounting bracket tilt angle for LUNA qualification.

15.3.1 Distribution Interactions With Other DLC Policies: Field Adjustable Light Distribution (FALD) and Field Adjustable Light Output (FALO)

The following types of field adjustable light distribution (FALD) products may be eligible for LUNA qualification:

- Products that are levelable as described in Field Adjustable Light Distribution (FALD) and restrict tilt to 10 degrees or less to level the intensity distribution with the pavement are eligible for LUNA, but will not be listed with the FALD designation.
- Products whose light distribution is intentionally adjusted via changes to components of the luminaire, and adjustment does not change the U rating. For example, products with field adjustable optics that change the distribution classification from a Type II to a Type III are eligible, as long as the U rating in both adjustable settings is equal to or less than the maximum

U rating criterion for that PUD. Judgment as to whether a product’s light distribution adjustment impacts the U rating is at the discretion of the DLC. The DLC reserves the right to ask for additional technical information, including LM-79-19 or -24 and/or distribution reports, as needed for verification.

- It is important to note that the above restrictions may require the separation of models that were otherwise able to be combined on the SSL QPL, to clearly delineate those that are qualified under LUNA and those that are not.
- Field adjustable light output (FALO) products with selectable wattage and/or lumen output must be shipped at the lowest wattage or output setting to be LUNA qualified.

15.4 LUNA Spectral Quality Requirements

The spectral quality requirements for LUNA products that extend beyond SSL V6.0 requirements are outlined in [Table 24](#). The “QPL Listing” column describes the information that will appear publicly on the QPL listing, if applicable. The “Method of Evaluation” column describes how products will be evaluated for qualification, whether by compliance with industry standards, manufacturer documentation, or other DLC verification methodology. (For information on minimum required testing, see [Minimum Testing Requirements: LUNA Spectral Quality](#))

Table 24: LUNA V2.0 Spectral Quality Requirements

Metric and/or Application	Applicable Products	LUNA V2.0 Spectral Quality Requirements	QPL Listing	Method of Measurement or Evaluation
Chromaticity (CCT & D_{uv})	Non-Amber LUNA products, except lamps and retrofit kits	LUNA products shall exhibit chromaticity consistent with at least one of the basic, flexible, or extended nominal 7-step quadrangle CCTs from 1800 K – 3000 K.	Parent products: CCT, and D _{uv} for parent products is listed as Tested Data. Nominal CCT for child products is listed as Reported Data.	ANSI/IES LM-79 (See Additional Requirements for LM-79, LM-80, and TM-21 Test Reports) ANSI/IES TM-27-20 or IES TM-27-14
Chromaticity (CCT & D_{uv})	Non-Amber LUNA eligible lamps and retrofit kit products	LUNA products shall exhibit chromaticity consistent with at least one of the basic, flexible, or extended nominal 7-step quadrangle CCTs from 1800 K – 2700 K.	Parent products: CCT, and D _{uv} for parent products is listed as Tested Data. Nominal CCT for child products is listed as Reported Data.	Optionally: ANSI/IES TM-33-18 (or -23) <i>Note:</i> For LUNA qualification, LM-79 and/or color testing must be provided on a LUNA-qualifying product.



Metric and/or Application	Applicable Products	LUNA V2.0 Spectral Quality Requirements	QPL Listing	Method of Measurement or Evaluation
S/P Ratio	All LUNA parent products	All LUNA parent products will show the calculated S/P ratio. No threshold is stipulated.	Parent products: S/P ratio for parent products is listed as Tested Data.	S/P Ratio calculated with the LUNA pre-submission tool per the 2-degree scotopic and photopic luminous efficiency functions in ANSI/IES LS-2-20.
Percent Blue	All LUNA parent products	All LUNA parent products will show the calculated percent blue. No threshold is stipulated, except for Hawaii code compliance.	Parent products: % blue for parent products is listed as Tested Data.	% blue, per DLC's definition, calculated with the LUNA pre-submission tool.
Traffic compliance and Hawaii code compliance (Spectral Compliance Information)	All LUNA parent products	Traffic color compliant: LUNA parents that have chromaticities outside of ITE Yellow (amber) (per SAE J578 APR2020) per the DLC's definition. Hawaii code compliance: LUNA parents that are Hawaii code compliant will be traffic color compliant AND have percent blue ≤ 2%. ⁴	LUNA parents: Will report traffic color compliance and Hawaii code compliance. Will be listed using outputs from the LUNA pre-submission tool in the Tested Data section	Traffic compliance and Hawaii code compliance will be calculated with the LUNA pre-submission tool
Chromaticity (Spectral Compliance Information)	LUNA Amber products (luminaires, lamps, and retrofit kits)	Chromaticity consistent with technology-specific definitions provided in the <i>Amber Products</i> section.	Nomenclature for <i>Amber Products</i> (de-Amber, pc-Amber, Filtered Amber) for parent and child products.	ANSI/IES LM-79 ANSI/IES TM-27-20 or IES TM-27-14 Optionally: ANSI/IES TM-33-18
SPDX Document	All LUNA parent products	LUNA qualifying products tested to meet LUNA spectral quality requirements must submit an ANSI/IES TM-27 SPDX document containing spectral power distribution	LUNA parent products will display the SPDX document † under the Tested data section.	ANSI/IES TM-27-20 or IES TM-27-14 Optionally: ANSI/IES TM-33-18 (or-23)

⁴ To determine whether a product meets the percent blue threshold for Hawaii County or Maui County code compliance, the pre-submission tool compares the calculated result rounded to one decimal place with the 2.0% threshold. As long as the rounded percentage calculated from the spectrum is less than or equal to 2.0%, the product meets the criteria.

Metric and/or Application	Applicable Products	LUNA V2.0 Spectral Quality Requirements	QPL Listing	Method of Measurement or Evaluation
		data in increments of 5 nm or less. ANSI/IES TM-33 (-18 or -23) XML documents are also acceptable in addition to SPD files but are not required at this time.		
SPD Image	All LUNA parent products	Using the LUNA pre-submission tool, the submitter will create a PNG SPD image for the representative LUNA qualifying products included in the application.	For each color parent product, images from the LUNA pre-submission tool will be listed under the Tested Data section.	ANSI/IES TM-27-20 or IES TM-27-14 Optionally: ANSI/IES TM-33-18 (or -23) Submitted SPD images generated by the LUNA pre-submission tool from the submitted SPD files.

† *Table note:* Submitted [ANSI/IES TM-27-20](#) (or [IES TM-27-14](#)) will be available for download on the QPL. It is important to ensure that submitted SPD files do not contain information inappropriate for QPL display.

15.4.1 Spectral Quality Interactions With Other DLC Policies: FACT, CCT-Tunable, and Full Color-Tunable

CCT-tunable, field adjustable color temperature (FACT), and warm-dimming products are eligible for LUNA V2.0 if the maximum CCT in the product’s range is at or below the maximum-allowed LUNA CCT (i.e., 3000 K for luminaires and 2700 K for lamps and retrofit kits).

FACT products that have adjustable CCT setpoints within the LUNA eligible CCT range are eligible for LUNA (3000 K for luminaires and 2700 K for lamps and retrofit kits). Manufacturers that want to qualify FACT products to LUNA with CCTs above the LUNA maximum are eligible with a factory lock function (or similar functionality). The DLC reserves the right to ask for additional information as needed for verification.

Outdoor FACT products with adjustable CCTs must be shipped at the lowest CCT, which must be at or below 3000 K. Products that include selectable amber LED setpoints in addition to FACT may be shipped with the setting at the amber setpoint instead. For these luminaires, only the CCT setting(s) at 3000 K (or lower) will be eligible for LUNA and will be shown on the LUNA QPL. The DLC reserves the right to ask for additional information as needed for verification.

Full Color-Tunable products are not eligible for LUNA V2.0.

15.5 LUNA Controllability Requirements

In LUNA V2.0, the DLC no longer has additional controllability requirements. Instead, products seeking qualification under SSL V6.0 as Standard and under LUNA V2.0 must meet the SSL V6.0 controllability requirements for Standard. Similarly, products seeking qualification under SSL V6.0 as Premium and under LUNA V2.0 must meet the SSL V6.0 controllability requirements for *DLC Premium*.

15.6 LUNA Turtle Lighting PUD Requirements

The spectral LED requirements for Turtle Lighting luminaires build on other de-Amber requirements in SSL V6.0 and LUNA V2.0. Luminaire efficacy and lumen maintenance requirements for de-Amber LEDs are provided in [Table 16](#) and Table 30.. [Table 24](#) provides the spectral requirements for all LUNA products, including de-Amber. [Table 25](#) provides the requirements for the three new Turtle Lighting PUDs. Turtle Lighting PUDs also have to meet the LUNA V2.0 distribution requirements in [Table 23](#). Filtered Amber LED luminaires are not allowed for turtle lighting PUDs because filters are easily removed and would no longer be compliant with the intended use for turtle habitats. Specification sheets must include applicable nomenclature, such as “Turtle Safe,” “Turtle Friendly,” or “Wildlife Friendly,” to indicate that the product is intended for use in applications where sea turtles are present. These terms are required only to support the DLC’s review process. The DLC does not verify the accuracy of these designations, nor should their inclusion be interpreted as approval, validation, or endorsement by the DLC.

Table 25: Turtle Lighting PUD Requirements: Light Output and Distribution

Primary Use Letter	Primary Use Designation	Maximum Light Output (lm)	Amber LED type	Maximum U Rating	Maximum G Rating
BF	Turtle Lighting Zero-Uplight Pole/Arm-Mounted Area and Roadway Luminaires	8,000	de-Amber	U0	G1
BG	Turtle Lighting Zero-Uplight Wall-Mounted Area Luminaires	2,500	de-Amber	U0	G0
BH	Turtle Lighting Zero-Uplight Bollards	1,000	de-Amber	U0	G0

15.7 LUNA Testing and Reporting Requirements

LUNA V2.0 testing and reporting requirements align with those of SSL V6.0, with one exception noted below.

15.7.1 LM-79 Testing

Any required LM-79/Color or LM-79/Distribution testing specific to the LUNA technical requirements must be conducted on LUNA-qualifying products, even for family groups that include LUNA and non-LUNA products. Distribution and color testing conducted with non-LUNA products is insufficient to meet the LUNA V2.0 technical requirements.

Additional details on SSL V6.0 requirements are provided in the [Additional Requirements for LM-79, LM-80, and TM-21 Test Reports](#) section.

15.7.2 LM-79 Reporting

Light distribution: Distribution reports and photometric files must conform with SSL V6.0 reporting requirements, with one additional requirement. LUNA V2.0 products for which efficacy allowances for shielding are requested will be required to include a product photograph of the luminaire with the shield in their LM-79 distribution report(s), with sufficient resolution in the photograph that the shield is clearly visible. The DLC encourages manufacturers to additionally include [ANSI/IES TM-33-18](#) or -23 XML documents with their LUNA V2.0 submissions, although it is not required.

Spectral Quality: For all new applications under LUNA V2.0, manufacturers must submit a light spectrum report and an [ANSI/IES TM-27-20](#) or [IES TM-27-14](#) SPD file, and may optionally submit an [ANSI/IES TM-33-18](#) or -23 XML document.

TM-33 file submission: From a file format perspective, the DLC encourages adoption and use of [ANSI/IES TM-33-18](#) or -23 XML documents, in addition to IES and SPD file formats, for the following reasons:

- Combines spectral and luminous intensity data
- Includes many commonly used metrics (e.g., color rendition metrics)
- Allows for calculation of alternative field-application metrics (e.g., to support metrics beyond lumens)

The DLC realizes that photometric testing and illumination-engineering software do not currently support [ANSI/IES TM-33-18](#) or -23 export/import and is therefore providing reporting alternatives in LUNA V2.0. File types IES and SPD are required in LUNA V2.0, and [ANSI/IES TM-33-18](#) or -23 XML documents are optional.

15.8 Efficacy Allowances for LUNA Qualified Products

The DLC acknowledges that luminaire efficacy will be reduced with a shield mounted on the luminaire and provides a LUNA shielding efficacy allowance (specified in [Table 26](#)) to encourage well-shielded products to be listed on the QPL. Efficacy allowances for LUNA qualified products are provided to encourage shielded luminaires to be listed and to account for the decreased efficacy due to light-controlling optics and baffles. Auxiliary shielding may increase the quality of the light distribution of a luminaire by helping to ensure that the light is delivered where intended and does not cause light trespass on neighboring locations. However, the application of shields often results in lower luminaire

efficacy, and in many cases, shielded products cannot meet the DLC’s minimum efficacy requirements without special allowances.

Additional efficacy allowances that apply to products qualified under LUNA V2.0 are summarized in Table 26. These allowances may be added to other spectral quality allowances provided under SSL V6.0 for a maximum allowance of 45%.

The DLC is providing efficacy allowances for all LUNA qualified bollards, as well as area lighting, roadway lighting, and pole- or arm-mounted decorative lighting with house-side shields (HSS), cul-de-sac shields (CSS), and front-side shields (FSS) that reduce house-side (for HSS and CSS) or street-side (for FSS) lumens by the percentages specified in [Table 26](#). Although manufacturers must demonstrate that at least one shield option or accessory is available for LUNA qualification, listing additional specific LUNA qualified products with shields is voluntary.

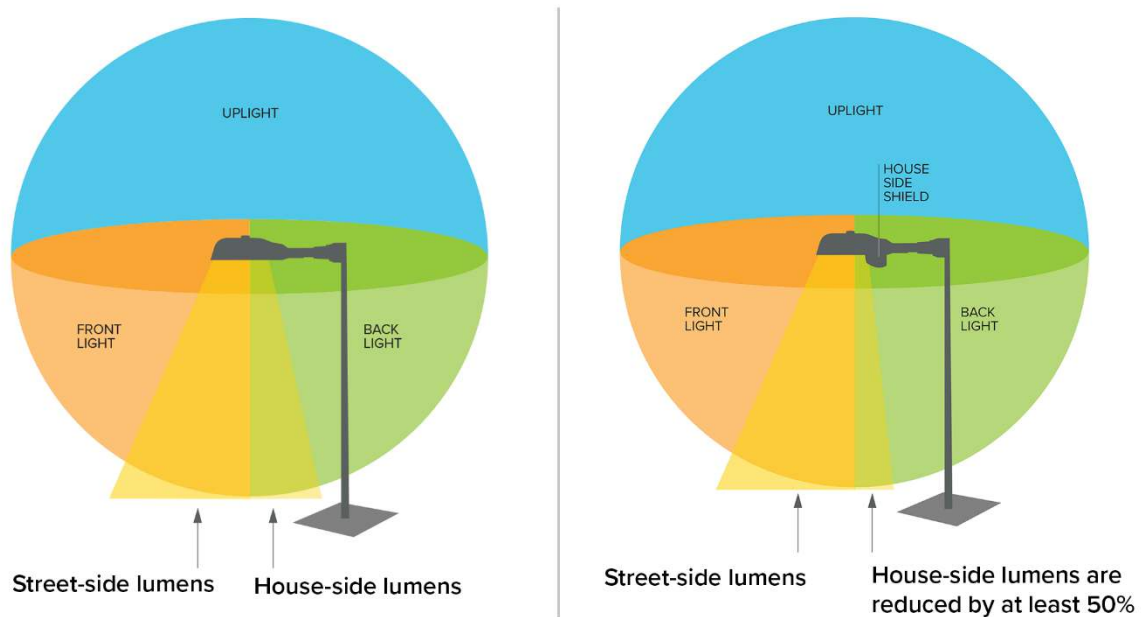

Figure 2: Example of a hypothetical product with a house-side-shield (HSS) (right image) and without (left image). The one with a HSS would be eligible for a shielding efficacy allowance if the house-side lumens were reduced by at least 50% compared to those from an unshielded equivalent product. It is important to note that shielding efficacy allowances for other shield types will require different reductions in house-side or street-side lumens, per [Table 26](#).

Table 26: Efficacy Allowances Specific to LUNA Products

Feature	Primary Use Designation	Performance Metric	Allowance Under V6.0
All Bollards	Bollards	N/A	-25%
Shielding	<ul style="list-style-type: none"> • Outdoor Pole/Arm-Mounted Area and Roadway Luminaires • Outdoor Pole/Arm-Mounted Decorative Luminaires • Hazardous Environment Area Lighting • Specialty: Hazardous Environment Outdoor Pole/Arm-Mounted Area and Roadway Luminaires 	Luminaires with internal or external house-side shields (HSS) that reduce the house-side lumens by at least 50% compared to those from an unshielded equivalent product.	-20%
		Luminaires with internal or external cul-de-sac shields (CSS) that reduce the house-side lumens by at least 70% compared to those from an unshielded product.	-35%
		Luminaires with internal or external front-side shields (FSS) that reduce the street-side lumens by at least 30% compared to those from an unshielded product.	-20%

15.8.1 Documentation Requirements for LUNA Efficacy Allowances

For LUNA qualified products for which a shielding allowance is requested, the submitted specification sheet or supplemental documentation should clearly show the calculated efficacy for the unshielded product and for the shielded product. In addition to the IES file, the LM-79/Distribution report for the worst-case distribution parent must be submitted as a PDF file and must include a product image with the shield. This image must have sufficient resolution that the shield is clearly visible. (For information on minimum required testing, see [Minimum Testing Requirements: LUNA Shielding Efficacy Allowances.](#))



Part V: Requirements for Specialized Product Types

Part V specifies specialized product types for which unique considerations are necessary in addition to or different from the requirements detailed in Parts II through IV. Covering a range of product types such as field adjustable, color tunable, amber, solar powered, and more, Part V ensures that each product type is addressed with tailored criteria. In addition to meeting all applicable DLC Standard, Premium, or LUNA technical requirements, specific products must comply with the appropriate provisions within Part V to be eligible for listing.



16 Field Adjustable Products

16.1 Introduction

To better align with industry standards and differentiate between field adjustable and controllable products, the SSL V6.0 revises the previous definition of “field adjustable” and reorganizes how field adjustable product attributes are presented on the QPL.

Field Adjustable is defined as the capability of a product to enable the installer to change the CCT and/or output and/or light distribution, through either physical or electronic means, while the installer is physically located at the luminaire *at the time of installation*. Field adjustable parameters are intended to be set at the time of installation but are not intended to be actively changed during the normal course of luminaire operation. Similarly, an LED driver for which precise adjustments to light output are typically performed at the factory or distribution warehouse and are not available to the installer is not considered a field adjustable product.

By contrast, dimmable products are not considered to be field adjustable. These products enable the end user to change the light output of a luminaire, through physical or electronic means, while the user is located at a distance from the luminaire *after the time of installation*. Dimming adjustments are commonly made repeatedly in the normal course of luminaire operation.

CCT-Tunable products are not considered to be field adjustable. These products enable the end user to change the correlated color temperature (CCT) of a luminaire, through physical or electronic means, while the user is located at a distance from the luminaire *after the time of installation*. CCT-Tunable adjustments are commonly made repeatedly in the normal course of luminaire operation.

The field adjustable set point is fixed by the manufacturer, distributor, installer, or commissioning agent before or during installation or commissioning, via a control that is made discrete to that purpose (i.e., not part of a regular occupant- or sensor-facing control system). Typically, field adjustable settings are not occupant-facing and are not intended to be changed in the normal course of luminaire operation.

Field Adjustable products will be clearly marked as Field Adjustable in search results on the SSL QPL, and details of Field Adjustable product features will be displayed together on QPL Product Detail pages.

The DLC recognizes three types of field adjustable products: Field Adjustable Color Temperature (FACT), Field Adjustable Light Output (FALO), and Field Adjustable Light Distribution (FALD). In SSL V5.1, products with Field Adjustable Color Temperature were covered under the color tuning policy. To better align with the market, SSL V6.0 has moved Field Adjustable Color Temperature to the Field Adjustable Products section.

Unless otherwise noted, all DLC Standard, Premium, and LUNA program requirements remain applicable in addition to the thresholds and testing requirements specified in this section.

16.2 Field Adjustable Color Temperature (FACT)

Field Adjustable Color Temperature (FACT) products enable the user to make changes to the correlated color temperature (CCT), through either physical or electronic means, while the user is physically located at the luminaire at the time of installation. Field adjustable parameters are not intended to be changed in the normal course of luminaire operation.

The default CCT setting for FACT products is defined as the CCT at which the product emerges from production and is shipped, with no adjustments to CCT. Tunable ranges and tested chromaticity data for FACT products must comply with the provided chromaticity requirements in

Table 4, i.e., FACT products must be consistent with the ANSI/NEMA C78.377-2024 binning and D_{uv} limits and shall not adjust to CCTs beyond the eligible range for the General Application(s) and Primary Use(s) for which they are submitted. Like CCT-Tunable products, FACT products must maintain nominally constant lumen output (i.e. within 20% light output) between any CCT measurement across the full range of CCT settings.

Testing of FACT products shall follow the requirements detailed in the *Minimum Testing Requirements: CCT-Tunable, Full Color-Tunable, and FACT Products* section.

Table 27 details the reported data requirements for FACT products.

Table 27: Field Adjustable Color Temperature Reported Data

Field	Definition	Acceptable Terms Denoting CCT on the Product Specification Sheet or in Supplemental Literature
Default CCT Setting	The setting at which the product emerges from production and is shipped, with no adjustments to CCT.	xxxxK xxxx K x K x.x K
CCT Setting 1	The CCT of the luminaire at the lowest setting.	xxxxK xxxx K x K x.x K
CCT Setting 2	The CCT of the luminaire at the second lowest setting.	xxxxK xxxx K x K x.x K
CCT Setting 3	The CCT of the luminaire at the third lowest setting.	xxxxK xxxx K x K x.x K

Field	Definition	Acceptable Terms Denoting CCT on the Product Specification Sheet or in Supplemental Literature
CCT Setting 4	The CCT of the luminaire at the fourth lowest setting, if needed.	xxxxK xxxx K x K x.x K
CCT Setting 5	The CCT of the luminaire at the fifth lowest setting, if needed.	xxxxK xxxx K x K x.x K
CCT Setting 6	The CCT of the luminaire at the sixth lowest setting, if needed.	xxxxK xxxx K x K x.x K
CCT Setting 7	The CCT of the luminaire at the seventh lowest setting, if needed.	xxxxK xxxx K x K x.x K
CCT Setting 8	The CCT of the luminaire at the eighth lowest setting, if needed.	xxxxK xxxx K x K x.x K

16.3 Field Adjustable Light Output (FALO)

Field Adjustable Light Output (FALO) products are lamps, luminaires, and retrofit kits that are capable of being adjusted to decrease or increase lumen output and wattage from the default setting, through either physical or electronic means, while the user is physically located at the individual luminaire. This capability is reported separately from the required dimming capability. As per the [Dimming Requirements](#), lamps must be capable of either FALO or continuous dimming.

[Table 28](#) details the reported data requirements for FALO products.

Table 28: Field Adjustable Light Output and Wattage Reported Data

Field	Definition	Acceptable Terms on the Product Specification Sheet or in Supplemental Literature
Default Lumen Output	The setting at which the product is shipped, with no adjustments to lumen output.	xxxxx lm xxxxx lumens



Field	Definition	Acceptable Terms on the Product Specification Sheet or in Supplemental Literature
Lumen Output Setting 1	The lumen output of the luminaire at the lowest setting.	xxxxx lm xxxxx lumens
Lumen Output Setting 2	The lumen output of the luminaire at the second-lowest setting.	xxxxx lm xxxxx lumens
Lumen Output Setting 3	The lumen output of the luminaire at the third lowest setting.	xxxxx lm xxxxx lumens
Lumen Output Setting 4	The lumen output of the luminaire at the fourth lowest setting, if needed.	xxxxx lm xxxxx lumens
Lumen Output Setting 5	The lumen output of the luminaire at the fifth lowest setting, if needed.	xxxxx lm xxxxx lumens
Lumen Output Setting 6	The lumen output of the luminaire at the sixth lowest setting, if needed.	xxxxx lm xxxxx lumens
Lumen Output Setting 7	The lumen output of the luminaire at the seventh lowest setting, if needed.	xxxxx lm xxxxx lumens
Lumen Output Setting 8 (Highest)	The lumen output of the luminaire at the eighth lowest setting, if needed.	xxxxx lm xxxxx lumens
Default Wattage	The setting at which the product is shipped, with no adjustments to lumen output.	xxxx W xxxx Watts
Wattage Setting 1 (Lowest)	The power demand of the luminaire at the lowest setting.	xxxx W xxxx Watts
Wattage Setting 2	The power demand of the luminaire at the second lowest setting.	xxxx W xxxx Watts
Wattage Setting 3	The power demand of the luminaire at the third lowest setting.	xxxx W xxxx Watts
Wattage Setting 4	The power demand of the luminaire at the fourth lowest setting, if needed.	xxxx W xxxx Watts
Wattage Setting 5 (Highest)	The power demand of the luminaire at the fifth lowest setting, if needed.	xxxx W xxxx Watts
Wattage Setting 6	The power demand of the luminaire at the sixth lowest setting, if needed.	xxxx W xxxx Watts
Wattage Setting 7	The power demand of the luminaire at the seventh lowest setting, if needed.	xxxx W xxxx Watts
Wattage Setting 8 (Highest)	The power demand of the luminaire at the eighth lowest setting, if needed.	xxxx W xxxx Watts

16.4 Field Adjustable Light Distribution (FALD)

Field adjustable light distribution (FALD) products are lamps, luminaires, or retrofit kits whose light distribution can be intentionally changed from the default factory “as-shipped” configuration, through either physical or electronic means, only while the user is physically located at the individual luminaire. Typically, field adjustable light distribution settings are not occupant facing and are not intended to be changed in the normal course of luminaire operation.

The DLC recognizes only one category of products that are capable of in-field distribution adjustments and can be classified as FALD:

- Products whose light distribution can be changed, either through integral means or where standard components are shipped with the product.

The following categories of in-field distribution adjustments *do not qualify* as FALD for the purpose of meeting SSL V6.0 requirements.

- Aimable: These are products capable of in-field adjustment to change the direction of the light distribution (both pan and tilt) in relation to nadir.
- Levelable: These are products capable of an in-field tilt-only adjustment of 10 degrees or less.

Products will be labeled as FALD, Aimable, or Levelable on the QPL.

FALD products eligible for listing on the SSL QPL fall into one or both types based on the method used to intentionally adjust their light distribution:

1. **Integral Field Adjustable Light Distribution Products:** Products where the distribution can be adjusted by electrical or mechanical means without the addition, removal, or replacement of any parts or accessories. The means of adjustment must be integral to the product. For example, a luminaire with built-in aimable light bars to direct the light at different angles would fall under this category.
2. **Standard Component Field Adjustable Light Distribution Products:** Products where the distribution is adjusted by adding or removing parts that are included with the product as sold under a single model number. These interchangeable components that come as standard with a single model number are defined as “Standard Components” for this policy. An example of this type of FALD product is a luminaire that is shipped standard with three reflectors under a single model number, and for which the installer chooses one of the reflectors during the installation and stores or discards the other two reflectors.

Products where the distribution is adjusted by adding parts that do *not* come standard with every order—termed “optional components” in this policy— and are not considered to be FALD. Optional components are considered accessories and are excluded from the DLC QPL with exception of LUNA shields/mounts.

The testing and listing requirements for the two FALD types defined above are identical, as described in the FALD Eligibility, Minimum Testing Requirements: FALD and Listing on the QPL sections below. SSL

QPL applications for FALD products will be required to specify which of the two types above, or both, apply to the product.

The DLC will rely on manufacturers and submitters to appropriately indicate whether their product has FALD capabilities. However, the DLC reserves the right to ask for additional information to clarify product capabilities related to tilting, aiming, and/or leveling.

Table 29 details the reported data requirements for FALD products.

Table 29: Field Adjustable Light Distribution Reported Data

Field	Definition	Acceptable Terms on the Product Specification Sheet or in Supplemental Literature
Field Adjustable Distribution Type	Either Integral Field Adjustable Light Distribution or Standard Component Field Adjustable Light Distribution	N/A
Field Adjustable Distribution Metric	The metric by which FALD setting information will be submitted.	Degree Range IES Distribution Types (Outdoor only) NEMA Flood Types (Outdoor only) Up/Down/All Left/Right/All Other
Distribution Setting Default	The setting at which the product emerges from production and is shipped, with no adjustments to distribution settings.	xxx° xxx degrees Type x NEMA x
Distribution Setting 1 (Narrowest)	The distribution of the luminaire at the narrowest or most concentrated setting.	xxx° xxx degrees Type x NEMA x
Distribution Setting 2	The distribution of the luminaire at the second narrowest or most concentrated setting.	xxx° xxx degrees Type x NEMA x
Distribution Setting 3	The distribution of the luminaire at the third narrowest or most concentrated setting.	xxx° xxx degrees Type x NEMA x

Field	Definition	Acceptable Terms on the Product Specification Sheet or in Supplemental Literature
Distribution Setting 4	The distribution of the luminaire at the fourth narrowest or most concentrated setting, if needed.	xxx° xxx degrees Type x NEMA x
Distribution Setting 5 (Widest)	The distribution of the luminaire at the fifth narrowest or most concentrated setting, if needed.	xxx° xxx degrees Type x NEMA x

16.4.1 FALD Eligibility

The following are eligibility rules for FALD products:

- *All FALD products must meet all DLC Technical Requirements except distribution requirements for the Category and Primary Use Designation (PUD) under which they are being submitted across the full range of the product’s light distribution integral settings and standard components.* This range includes all adjustments of either mechanical or electrical means, including software-based methods, and all possible combinations of distribution-adjusting parts that are included standard under a single model number. If a Standard Component FALD product may be installed without any distribution-adjusting component attached, then the product must meet all DLC Technical Requirements for the Category and PUD under which it is submitted, both with and without any standard components.
 - An exception to the above rule for evaluating light output of high-bay and low-bay FALD products occurs in the following situation: For both new luminaires and integrated retrofit kits within the High-Bay General Application, products will be deemed to meet the DLC Technical Requirements for light output if they meet the DLC technical requirement for minimum and maximum light output for any Primary Use Designation within the High-Bay General Application. Some PUDs — for example, High-Bay Luminaires for Commercial and Industrial Buildings and Low-Bay Luminaires for Commercial and Industrial Buildings — differ only in light output, with requirements above and below 10,000 lumens respectively. If field adjustment to the light distribution causes the light output of a high-bay product to cross below the 10,000-lumen threshold, that product will still be eligible as long as it meets the light output requirement of the low-bay PUD, i.e., as long as it maintains light output above 5,000 lumens.
- *All FALD products must meet the DLC Technical Requirements for distribution requirements for the PUD under which they are being submitted at one light distribution setting of the manufacturer’s choosing.* This setting must be one integral adjustment setting and/or one

combination of distribution-adjusting standard components. The product is not required to meet the ZLD and spacing criteria (if applicable) requirements at other light distribution settings.

- *For products that include both Integral FALD and Standard Component FALD, the tested integral light distribution setting should be suitable for the intended use of each light distribution-adjusting component or accessory and need not be identical across all light distribution-adjusting accessories.*
- A product meeting the FALD definitions above may also be offered with optional components or accessories that can be ordered separately or as an option within a unique model number for further adjusting its light distribution. *Products that include both FALD and optional components that adjust light distribution must be submitted as separate application line items with distinct model numbers for each distribution-adjusting component combination, each of which is treated as a FALD product.*
- FALD products will only be classified as DLC Premium if they meet all [DLC Premium classification requirements](#) for the Category and PUD under which they are being submitted.
- FALD products that fall under other DLC product Category and Primary Use eligibility rules, such as [Color-Tunable](#) or [Dimmable](#) products, are additionally subject to those respective Testing and Reporting Requirements. It is important to note that if a control measure that changes a luminaire’s light distribution also results in significantly different light output, provisions of the Dimmable and Field Adjustable Light Output policy also apply.

16.5 Supporting Documentation

The DLC will evaluate manufacturer claims of a product’s FALD capability by ensuring that the adjustability claims are clearly published in the product specification sheet(s) and correspond with the unique model numbers submitted. The DLC will also evaluate the manufacturer’s product installation instructions to determine eligibility. Documentation must include instructions for adjusting light distribution, including any required device or software. The instructions must be the same ones provided to the intended installers or consumers who will be making the light distribution adjustments. DLC reviewers may check web listings and other marketing materials and reserve the right to request additional information to demonstrate capability if information in product specification sheets is not sufficient.

16.6 Listing on the QPL

16.6.1 FALD Listing on the QPL

FALD products will be identified as such under the “Field Adjustable” tab on the SSL Qualified Products List (QPL) as either “Integral FALD,” “Standard Component FALD,” or “Integral and Standard Component FALD.”



All relevant details of FALD products will be displayed at the distribution setting that produces the worst-case efficacy.

The Zonal Lumen Distribution (ZLD) listing on the QPL for each family member will be calculated from the IES file designated by the manufacturer as applicable to that family member.

A text field, Tested Adjustable Distribution Setting, will be reported on the QPL for Integral FALD products to document the light distribution setting or Standard Component configuration designated by the manufacturer to meet the Zonal Lumen Distribution requirement for the PUD.

16.6.2 FACT Listing on the QPL

FACT products will be identifiable on the QPL as “FACT” or “Field Adjustable Color Temperature”.

All relevant details of FACT products will be displayed at the worst-case efficacy CCT setting.

Additionally, all FACT CCT settings reported as described in Table 27 will display on the QPL.

All relevant details of FACT products will be displayed at the worst-case efficacy CCT setting.

16.6.3 FALO Listing on the QPL

FALO products will be identifiable on the QPL as “FALO” or “Field Adjustable Light Output”.

All relevant details of FALO products will be displayed at the maximum FALO setting.

Additionally, all FALO light output and wattage settings reported as described in Table 28 will display on the QPL.

16.7 Additional Notes

16.7.1 Considerations for LED CFL Replacements (“CFLEDs”)

For horizontally mounted LED replacements for pin-based CFLs (“CFLEDs”), because CFLED policy has historically required such products to be rotatable, testing in an orientation where the light from the lamp is directed out of the recessed can housing is appropriate. Additional adjustability, such as “heads” on the end of the lamp that can point in multiple directions, will be required to meet the additional provisions of the FALD policy and be tested in a worst-case orientation.



17 Color-Tunable Products

17.1 Introduction

The DLC qualification process relies on accurate testing of specific product models to demonstrate compliance with technical requirements. Compared to static-spectrum products, color-tunable products' dynamic performance requires unique considerations for demonstrating compliance to DLC requirements. These color-tunable specific considerations and requirements are detailed in this section. To better support the increasing demand for color tuning capabilities, SSL V6.0 and LUNA V2.0 classify Color-Tunable products as either CCT-Tunable, Warm-Dimming, or Full Color-Tunable. Unless otherwise noted, all DLC Standard, Premium, and LUNA program requirements remain applicable in addition to the thresholds and testing requirements specified in this section.

17.2 Definitions of Color-Tunable Products

A Color-Tunable product is defined as one whose output spectrum can be adjusted via an input control of any type and which is intended to be tuned/adjusted over the course of normal operation (i.e., not configured at installation and left unchanged). Products supplying white and colored light (i.e., those capable of generating color points with D_{uv} magnitudes beyond the limits of the ANSI/NEMA C78.377-2024 specification, also known as Full Color-Tunable) are eligible under SSL V6.0 and will only be evaluated against qualifying thresholds as if they are CCT-Tunable at this time.

CCT-Tunable products must utilize a control interface or multiple interface options clearly described in the product literature that allow for at least two CCT settings. These may be continuously variable inputs such as a 0-10 V DC signal, an established protocol such as DALI or DMX512, a proprietary control signal, setting options described in terms of CCT, such as 3000 K or 5000 K, or simple descriptive terms such as "Night" or "Day."

Three types of products are eligible for listing as Color-Tunable:

- **CCT-Tunable products** have a control signal specifically for adjusting CCT while maintaining nominally constant lumen output. These products may include a second, independent dimming control. CCT-Tunable products generally include products that combine the output of two LED primaries and products with three or more white and/or RGB LED primaries, so long as they only produce light in standardized quadrangles as defined in ANSI/NEMA C78.377-2024 in response to their control signal.
 - For a CCT-tunable product, Standard or Premium, to exhibit constant lumen output, the light output must not vary more than 20% between any CCT measurements across the full range of the CCT adjustment control signal. This will be verified by testing at the minimum, maximum, and intermediate CCT control input, as well as the reported lumen output values for each ANSI CCT Quadrangle during the application submission process.

Products whose light output varies by more than 20% between CCT measurements (excluding light output changes resulting from a separate dimming control signal) are not eligible at this time.

- **Warm-Dimming products** have a single input that controls both CCT and lumen output, lowering the values of both concurrently, most typically to mimic the CCT shift that occurs with incandescent dimming. Products that require an external control system to coordinate dimming and warm-dimming CCT are not eligible.
- **Full Color-Tunable products** have a control signal specifically for adjusting spectral output while maintaining nominally constant lumen output. These products may include a second, independent dimming control. Full Color-Tunable products include products that combine the output of three or more white and/or monochromatic LED primaries or Color mixed LEDs (cm-LEDs) and are capable of producing light in the standardized quadrangles as defined in ANSI/NEMA C78.377-2024, as well as color points with D_{uv} magnitudes beyond the limits of the ANSI Extended specification as characterized above in response to their control signal.
 - Like CCT-Tunable products, Full Color-tunable products must maintain nominally constant lumen output (i.e. within 20% light output) between any CCT measurement across the full range of CCT setpoints

17.3 CCT-Tunable and Full Color-Tunable Eligibility

Unless otherwise noted, all DLC Standard, Premium, and LUNA program requirements remain applicable in addition to the thresholds and testing requirements specified in this section. The following are eligibility rules for CCT-Tunable and Full Color-Tunable products:

- CCT-Tunable and Full Color-Tunable products must meet the DLC Technical Requirements at all values of the color control signal for the General Application(s) and Primary Use(s) for which they are submitted as described below.
- [Table 4](#) and Table 21 do not apply to Full Color-Tunable products. However, Full Color-Tunable products must align with the D_{uv} limits of the ANSI/NEMA C78.377-2024 binning structure for threshold purposes of passing and failure when demonstrating compliance at any given CCT.
- [Table 4](#) or Table 21, i.e., CCT-tunable and warm-dimming products must be consistent with the ANSI/NEMA C78.377-2024 binning and D_{uv} limits and shall not tune to CCTs beyond the eligible range for the General Application(s) and Primary Use(s) for which they are submitted.
- The evaluation of the tested CCT against the reported CCT is reviewed for all full LM-79/Color reports, including but not limited to, testing for minimum and maximum CCT values as well as the worst-case efficacy product for all Color-Tunable product types.
- Products must be capable of producing light at CCTs in alignment with existing CCT limits for DLC qualified products. However, no maximum or minimum CCT range is required for color tuning eligibility in general. *Efficacy Allowances* apply.

- Products will only be classified as DLC Premium if they meet all DLC Premium qualification requirements (except chromaticity as described above) at all values of the color control settings. Additional documentation may be required.
- Products may also have field adjustable lumen output characteristics, in which case they are also subject to the [Field Adjustable Products](#) Testing and Reporting Requirements.

17.4 Warm-Dimming Eligibility

The following are eligibility rules for Warm-Dimming products:

Warm-Dimming products must meet all DLC Technical Requirements, including CCT, for the General Application(s) and Primary Use(s) for which they are submitted, as measured at the maximum output for the product. The requirements include minimum lumen output, efficacy, CRI, CCT, lumen maintenance, THD, power factor, and zonal distribution and/or spacing criteria requirements. Standard DLC allowances apply as outlined in [Table 18](#).

Warm-Dimming products do not need to meet DLC technical requirements at other input control settings, i.e., when they are dimmed below full output.

Warm-Dimming products will only be classified as DLC Premium if they meet all DLC Premium qualification requirements at the maximum input control setting.

Warm-Dimming products may also have field adjustable lumen output and can be listed under both. If products exhibit both performance features, they must comply with both sets of requirements. (For information on minimum required testing, see [Minimum Testing Requirements: Warm-Dimming Products](#).)

17.5 Supporting Documentation for Color-Tunable Products

17.5.1 Control Interface Documentation

Applicants shall provide the following supporting documentation with the application submittal. If any of the following information is not clearly documented in the product specification sheet or other supporting technical or marketing materials, the application will be considered incomplete, and the DLC reviewer will request additional information.

- Description of the method of input control, as well as photos showing control input location and control input mechanism
- Reference to any control standards or protocols utilized
- Clear instructions for how to achieve the settings required in the testing section. Identical instructions must be provided to the test laboratory for testing and to the DLC during the application review.

17.6 Listing on the QPL

Products will be identifiable on the QPL with either “CCT-Tunable,” “Full Color-tunable,” or “Warm-Dimming” values under a “Color Tuning” field. See 16.6.2 for Listing information FACT products. CCT-Tunable products will be listed on the QPL at the least efficacious setting, with the corresponding product performance characteristics from that LM-79 test: Light Output, Power Consumption, Efficacy, THD, Power Factor, CRI, CCT, Zonal Lumens, and Spacing Criteria. In addition, the QPL will display the Minimum Wattage, Maximum Wattage, Minimum CCT, Maximum CCT, Minimum Light Output, and Maximum Light Output as separate fields.

Warm-Dimming products will be listed on the QPL at the full output setting, with the product performance characteristics from that LM-79 test: Lumen Output, Power Consumption, Efficacy, THD, Power Factor, CRI, Maximum CCT, Minimum CCT, Zonal Lumens, Spacing Criteria. Warm-Dimming products will be listed with only the CCT value corresponding to the full output setting.



18 Amber Products

18.1 Introduction

LED luminaires with Amber LEDs or amber filters are used in niche applications such as semiconductor manufacturing, some wildlife sensitive habitats such as coastal beaches with nesting sea turtles, observatory-adjacent lighting applications, and dark sky projects where blue-violet light is restricted. SSL V6.0 includes several new PUD types and eligible Amber LED lighting products (see below and in *Definitions*).

Unless otherwise noted, all DLC Standard and LUNA program requirements remain applicable in addition to the thresholds and testing requirements specified in this section, which defines the performance metrics and thresholds for products with Amber LEDs.

18.2 Specifications for Amber LED Luminaires, Retrofit Kits, and Lamps

Due to a current lack of chromaticity standards for Amber LEDs for general illumination, the DLC has created definitions and nomenclature for Amber LED products (see Section [1.2 Definitions](#)). An ANSI C78 working group is concurrently developing a new chromaticity standard for NWL LEDs (BSR C78.378-202x), which is expected to include LED nomenclature and specifications for amber LEDs. If the definitions conflict with DLC's definitions or requirements, the DLC will consider modifying or augmenting the following requirements to address any inconsistencies.

Eligibility for Amber LED products with regard to efficacy, quality of light, and distribution is expanded in subsequent sections. To assist stakeholders in understanding product color performance for Amber LED lighting products, all Amber parent products will include a downloadable SPD document and an SPD plot. The following criteria related to Amber LEDs are defined by the DLC and are informed by the nomenclature used in Esposito and Radetsky (2023). Tolerances for dominant wavelength and FWHM bandwidth are given in [Table 19](#).

- **de-Amber:** Produced by a narrowband LED (such as an aluminum indium gallium phosphide (AlInGaP) LED). Chromaticity of the lamp, retrofit kit, or luminaire shall be outside of C78.377-2024 quadrangles, with a dominant wavelength between 590 and 605 nm and a full width at half maximum (FWHM) of 20 nm or less. Total optical radiation below 560 nm shall be no more than 1.0% (defined as the sum of the radiant energy emitted between 380 and 560 nm divided by the sum of the radiant energy emitted between 380 nm and 780 nm).
- **pc-Amber:** Produced by a broadband LED (such as a phosphor-converted (pc-) indium gallium nitride (InGaN) LED). Chromaticity of the lamp, retrofit kit, or luminaire shall be outside of C78.377-2024 chromaticity quadrangles, with a dominant wavelength between 590 and 605 nm, an FWHM of no more than 80 nm, and a secondary peak of short-wavelength radiant power in

the blue range. The total optical radiation below 500 nm shall be no more than 1% (defined as the sum of the radiant energy emitted between 380 and 500 nm divided by the sum of the radiant energy emitted between 380 nm and 780 nm).

- **Filtered Amber:** A white-LED (2200 K to 5000 K) lamp, retrofit kit, or luminaire with an amber filtered lens or optic that reduces the short wavelength radiation to no more than 2% of the total optical radiation (defined as the sum of the radiant energy emitted between 400 and 500 nm divided by the sum of the radiant energy emitted between 400 and 700 nm).
- **Traffic color compliant:** This term is defined as chromaticity values that are outside of ITE Yellow (Amber) (per SAE J578 APR2020). This metric will be calculated for all LUNA-qualified, outdoor Amber LED parent products based on the submitted SPD document. (*Note:* This definition is included in the Hawaii and Maui County Code criteria [$\leq 2\%$ blue and “traffic color compliant”].)

One example use-case for Amber LEDs is in Hawaii and Maui Counties. In their codes, the percent (%) blue is defined as the sum of the optical radiation between 400 and 500 nm divided by the sum of the optical radiation between 400 and 700 nm, and the maximum % blue is 2%. The % blue will be calculated for all LUNA-qualified, outdoor Amber LED parent products based on the submitted SPD document.

Other use-cases for Amber LEDs include outdoor lighting for sensitive areas, semiconductor manufacturing, observatory-adjacent lighting, and other specialized commercial and industrial lighting applications.

Performance requirements for Turtle Lighting products, which require de-Amber LEDs, are described in [Table 25](#).

18.3 Efficacy Requirements for Amber LED products

Efficacy requirements for Amber LED products are set based on Amber LED technology and apply to any product type eligible for qualification with the associated Amber technology. [Table 30](#) provides the efficacy thresholds that apply to Amber LED products.

Table 30: Efficacy Requirements for All Amber LED Products

Amber LED Technology	DLC Standard Minimum Efficacy (lm/W)
de-Amber	30
pc-Amber	70
Filtered Amber	95

18.4 Spectral Quality Requirements for Amber LED Products

The spectral quality requirements for Amber LED products are given in [Table 31](#).

Table 31: Testing and Reporting Requirements for Spectral Quality for Products with Amber LEDs (DLC Standard)

Metric and/or Application	Applicable Products	SSL V6.0 & LUNA V2.0 Standard Requirements	QPL Listing	Method of Measurement/Evaluation
Chromaticity (Spectral Compliance Information)	All Amber LED products	Chromaticity consistent with technology-specific definitions provided in the Amber Products section	<p><i>Amber Products</i> (de-Amber, pc-Amber, Filtered Amber) for parent and child products.</p> <ul style="list-style-type: none"> Amber parent products will also display the following from the LM-79/Color report under Tested Data: Dominant wavelength and Chromaticity coordinates 	ANSI/IES LM-79 ANSI/IES TM-27 SPDX file
SPDX Document	All Amber parent products	<p>Qualifying products with amber LEDs tested to meet Amber spectral quality requirements must submit an ANSI/IES TM-27 SPDX document containing spectral power distribution data in increments of 5 nm or less.</p> <p>ANSI/IES TM-33 (-18 or -23) XML documents are also acceptable in addition to SPDX files but are not required at this time.</p>	Amber parent products will display the SPDX document under the Tested data section.	<p>ANSI/IES TM-27-20 or IES TM-27-14</p> <p>Optionally: ANSI/IES TM-33-18</p>
SPD Image	All Amber parent products	Using the SPDX document in the Amber pre-submission tool, the submitter will create a PNG SPD image for the representative Amber qualifying products	For each Amber color parent product, images from the Amber pre-submission tool will be listed under the Tested Data section.	<p>ANSI/IES TM-27-20 or IES TM-27-14</p> <p>Submitted SPD images are generated by the Amber pre-submission tool from the submitted SPDX documents.</p>



Metric and/or Application	Applicable Products	SSL V6.0 & LUNA V2.0 Standard Requirements	QPL Listing	Method of Measurement/Evaluation
		included in the application. ⁵		
Color Rendition	Products are required to report data in terms of Option 1 and Option 2, but are not required to meet any thresholds.		All color rendition metrics for parent products from LM-79 test reports are listed as Tested Data.	ANSI/IES LM-79 ANSI/IES TM-30 CIE 13.3-1995
	All Amber products	Option 1: ANSI/IES TM-30: <ul style="list-style-type: none"> • IES R_f • IES R_g • IES $R_{cs,h1}$ Option 2: CIE 13.3-1995: <ul style="list-style-type: none"> • R_a (CRI) • R_9 	All color rendition metrics for child products are listed as Reported Data.	
Color Maintenance ⁶	All Amber products	<p>All Amber products must report the following metrics. No thresholds are stipulated.</p> <p>Chromaticity shift on the CIE 1976 (u', v') chromaticity diagram from $\approx 1,000$-hour measurement to $\approx 6,000$-hour measurement shall be reported to the DLC.</p> <p>Optional reporting of CS4 and CS7 values per ANSI/IES TM-35-19.</p>	V6.0 listed products will display CS4 and CS7 values for all products when reported.	ANSI/IES LM-80, and/or IES LM-84-14 and ANSI/IES TM-35-19

⁵ To determine whether a product meets the percent blue threshold for Hawaii County or Maui County code compliance, the pre-submission tool compares the calculated result rounded to one decimal place with the 2.0% threshold. As long as the rounded percentage calculated from the spectrum is less than or equal to 2.0%, the product meets the criteria.

⁶ It is important to note that optional reporting of ANSI/IES TM-35-19 CS4 and CS7 values is included in SSL V6.0 and LUNA V2.0, and that reporting pathways will be provided coinciding with the availability of a publicly available TM-35 calculator. Custom calculators will not be accepted for reporting CS4 and CS7 values.



19 Solar Powered Outdoor Luminaires

19.1 Introduction

Solar powered outdoor luminaires offer significant potential for decarbonization and resilience, as they rely primarily or entirely on solar energy. However, the complexity of component selection and the lack of industry-standardized reporting on key product characteristics provide barriers to the implementation of this technology. By listing solar powered luminaires on the QPL with consistently reported component information, the DLC aims to reduce these barriers by gathering and displaying the most critical data needed for system understanding and validation. The DLC also intends to support greater standardization in how manufacturers present performance data on their specification sheets. Unless otherwise noted, all DLC Standard, Premium, and LUNA program requirements remain applicable in addition to the thresholds and testing requirements specified in this section.

19.2 Special Considerations for Solar Powered Outdoor Luminaires

Luminaires that utilize photovoltaic cells to either supplement or fully provide input power are eligible for DLC qualification under the Solar Powered Outdoor Luminaire Category. DLC qualification for solar powered luminaires applies only to the luminaire component of the product or system. The DLC does not qualify solar panels, batteries, or other components of the product. All requirements and thresholds designated for Outdoor Luminaires in this document apply to products in the Solar Powered Outdoor Luminaire category as well. Solar Powered Outdoor Luminaires must either include a photocell or be controls ready if sold as a standalone luminaire. Therefore, Solar Powered Outdoor Luminaires are not eligible for Controls Category 1 in [Table 9](#).

Additional reported information is required for products qualified under this category, as described in [Table 32](#). The “Acceptable Terms” column lists terms that must be present on the product specification sheet or in supplemental documentation if a corresponding option is selected.

Table 32: Additional Reported Fields Required for Solar Powered Outdoor Luminaires

Reported Field	Options*	Description	Acceptable Terms
Configuration	Integrated	The solar panel, battery, and luminaire are installed as one unit. Generally, the solar panel is embedded in the top of the luminaire.	Integrated, All-in-one, Self-contained
	Split-type	The solar panel and battery are mounted separately from the luminaire, but all components are marketed as one product.	Split-type, Split-component, Two-piece, All-in-two Pole-integral Pole integrated
	Luminaire only	The luminaire is sold separately from any battery or solar panel components but is designed to be integrated into a solar luminaire system.	Solar-ready, Solar compatible
Grid Connection	Off grid	The luminaire receives 100% of its energy from a solar panel.	Off grid, Standalone, Autonomous, Grid free
	Hybrid	The luminaire is designed to receive energy from both a solar panel and the electric grid.	Hybrid, Dual input, Grid assisted, Grid connected, Grid tied
PV Wattage	Value in watts	Only applicable for products with “Integrated” or “Split-Type” indicated in the Configuration field.	N/A



Reported Field	Options*	Description	Acceptable Terms
Recommended Install Height	Range in feet	The recommended height from the ground to the luminaire. Only applicable for products with “Integrated” or “Split-Type” indicated in the Configuration field.	N/A
Battery Type	Lithium iron phosphate (LiFePO4)	Only applicable for products with “Integrated” or “Split-Type” indicated in the Configuration field.	Lithium iron phosphate, Lithium ferro phosphate, LiFePO ₄ , LFP
	Lead acid		Lead acid, Gel
	Nickel-metal hydride (NiMH)		Nickel-metal hydride, NiMH
	Lithium nickel manganese cobalt oxide (NMC)		Lithium nickel manganese cobalt oxide, NMC, NCM, Lithium-ion, Li-ion, Ternary lithium
	Lead crystal®		Lead crystal, Silicon dioxide, SiO ₂
Battery Capacity	Value in amp-hours	Only applicable for products with “Integrated” or “Split-Type” indicated in the Configuration field.	N/A
Battery Lifetime	Value in years	Time until battery degenerates to 80% capacity. Only applicable for products with “Integrated” or “Split-Type” indicated in the Configuration field.	N/A



Reported Field	Options*	Description	Acceptable Terms
Solar Panel Lifetime	Value in years	Time until the panel generates 80% of initial capacity. Only applicable for products with “Integrated” or “Split-Type” indicated in the Configuration field.	N/A

* Table note: All reported options and values in this table will be displayed on the QPL.

19.2.1 Testing Requirements: Solar Powered Outdoor Luminaires

A luminaire for which solar panels fully provide input power (i.e., off grid) will be treated as a DC product and should be tested in accordance with the [Direct Current \(DC\) and Power Over Ethernet \(POE\)](#) Policy. Luminaires that receive supplemental energy from the grid (hybrid) will be reviewed via benchtop electrical testing to determine if the luminaire is less efficient when powered by the solar panel (DC) or the grid (AC). If the luminaire is less efficient when powered by DC, it must be tested and listed according to the DC/POE Policy, with no AC input into the luminaire during any testing or rating of performance. If the luminaire is less efficient when powered by AC, it must be tested and listed as an AC product according to the requirements stated in **Part VI**, with no DC input into the luminaire during any testing or rating of performance.



20 Direct Current (DC) and Power Over Ethernet (POE)

20.1 Introduction

DC and POE systems have the potential to reduce electrical losses from AC to DC conversions, integrate directly with DC-generation sources such as solar and batteries, reduce installation costs, and connect more readily to IT infrastructure for advanced lighting control. Unless otherwise noted, all DLC Standard, Premium, and LUNA program requirements remain applicable in addition to the thresholds and testing requirements specified in this section. Meeting the requirements defined in this section will enable high quality DC and POE lighting products to be qualified and listed on the DLC SSL QPL.

DC and POE products are defined as SSL lamps, luminaires, and retrofit kits that are powered by DC voltage. POE products are a specific subset of DC products that comply with the IEEE 802.3 Standards for carrying both power and communication signals on Ethernet cables. Qualified products will be listed as DC or POE products on the DLC SSL QPL. If a DC or POE lamp, luminaire, or retrofit kit is also capable of being powered by alternating current (AC) and the manufacturer desires to have it listed as suitable for both AC and DC, then the AC listing of the product must have a distinct model number that is different from the DC listed product, and it must be separately qualified and listed.

The DLC lists DC and POE lamps, luminaires, and retrofit kits on the SSL QPL based only on the luminous efficacy of these products as measured at their DC power input. The overall energy consumption of a DC or POE system also depends on DC line losses and DC power source efficiency, in addition to the luminaire or lamp efficacy. However, given the variation in system architectures and power losses, the DLC does not publish system-level efficacies for DC or POE SSL products.

20.2 Testing Methods and Requirements

Testing for DC and POE products must be provided to cover all areas of investigation, as is required for AC family groups. Per the eligibility criteria above, **all DC and POE products must be submitted as a Level 2 application**, regardless of the number of products submitted. The requirements below apply to the DC or POE luminaire, lamp, or retrofit kit under consideration, as test reports will not be required on the DC power source.

1. The DC or POE product or group of products shall be tested according to the guidelines for electrical instrumentation of DC devices in the Illuminating Engineering Society's ANSI/IES LM-79-19 or -24 standard.
2. The intent of the LM-79 test reports required for DLC submission is measurement of the luminaire efficacy as well as other photometric characteristics under DC power without including DC power source conversion losses or line losses.



3. Many DC and POE products utilize cables with multiple conductors. LM-79 test reports shall be based on the sum of all power delivered to the product across all connected conductors. The test report shall document the number of powered conductors, and pair-wise grouping if applicable.
4. Voltage and current measurements shall be made at the point of entry to the luminaire or retrofit kit, or at the input terminals to the driver in the case of UL Type C replacement lamps. For luminaires and retrofit kits, these measurements shall include any DC-to-DC driver circuitry that is included and shipped under the same model number as the luminaire or retrofit kit, but shall exclude drivers that need to be ordered separately under a different model number. For UL Type C replacement lamps, these measurements shall include the remote DC-to-DC driver circuitry. If the test laboratory is in doubt about the proper interconnection or placement of voltage-sensing leads for power measurement, they should consult the manufacturer.
5. Test laboratories should connect measurement equipment in a manner that will create minimal disruptions to data communication if the DC power connection carries both data and power. Manufacturers should, if necessary, provide testing labs with instructions for achieving a state of full light output without the consumption of unnecessary communication power.
6. Any removable accessories not required to achieve full light output, such as removable photosensors or occupancy sensors, shall be removed during LM-79 testing. Any accessories with controllable power states that are not required in order to achieve full light output, such as cameras, microphones, or external luminaire power connections, shall be disabled or powered down during LM-79 testing.
7. The luminous efficacy determined by the LM-79 Test shall be provided at the DC input voltage that results in the worst-case luminous efficacy. The test voltage must result in the worst luminous efficacy across the product's operating input voltage range and, if applicable, within the input voltage range of the established system protocol (e.g., IEEE 802.3at or IEEE 802.3bt).
8. For any application where the LM-79 test voltage submitted as worst-case is not the lowest voltage in the operating input voltage range, the manufacturer must submit a written justification explaining why their product performs at lower luminous efficacy at the higher input voltage. A tolerance of the greater of 1% or 1 volt will apply to the test voltage reported on the LM-79 test report. For example, a manufacturer submitting a product listed with an input voltage operating range of 24 to 30 VDC must either submit a test between 23 V and 25 V, or test at another voltage between 23 V and 31 V and include a justification as to why 24 V is not the worst-case luminous efficacy for that product. Justifications should explicitly reference any component or design features that affect performance across voltage range, such as constant-current drivers. For products with a minimum operating input voltage greater than the minimum of the nominal range, the operating input voltage range should be included in the written justification.
9. Input voltage ranges for POE products are specified in the IEEE 802.3 standards for each powered device Type and Class. However, because minimum input voltages across Type and Class vary by only a few volts and products may operate across multiple Classes, POE products shall be tested at 45 V or the minimum input voltage for their Type and Class if greater than 45 V. POE products must either be submitted with a test within 1 V of 45 V or their minimum input voltage from Table 33, or



be submitted with a test at another voltage within the IEEE 802.3 input voltage range, along with a justification as to why that voltage produces the worst-case luminous efficacy for that product.

Table 33: Powered Device Minimum Input Voltage*

Powered Device Assigned Class	Power Sourcing Equipment Type			
	Type 1	Type 2	Type 3	Type 4
Class 1	42.9	49.0	49.0	51.1
Class 2	42.1	48.3	48.3	50.4
Class 3	39.9	46.5	46.5	48.7
Class 4	—	42.5	42.5	44.9
Class 5	—	—	44.4	46.6
Class 6	—	—	42.5	44.9
Class 7	—	—	—	44.9
Class 8	—	—	—	43.0

* *Table note:* Manufacturers submitting a product without either an LM-79 test at the lowest voltage or a written justification will be required to submit a new test.

20.3 Listing on the QPL

Six fields specific to DC/POE listings are maintained under V6.0, two of which are exclusively applicable to POE:

- **“System Type”:** This field applies to all products on the QPL and is populated with text as “AC,” “DC,” or “POE.”
- **“Test Voltage”:** This new field is required for DC and POE products and may also be applied to existing AC products. It is a numerical value that lists the voltage from the LM-79 test report (e.g., 24 volts, 380 volts) that corresponds to the worst-case luminous efficacy listed for that product.
- **“Voltage Range”:** This new field applies to both AC and DC products and lists the nominal input voltage range for the product (e.g., 120-277 VAC, 44-57 VDC).
- **“DC Efficacy”** This new field lists the worst-case efficacy of DC and POE products, which is different from the current “Efficacy” field for existing products. The existing “Efficacy” field on the DLC QPL has been changed to “AC Efficacy” to clearly differentiate from the “DC Efficacy” of DC and POE products.



- **“POE Type/Class”**: This field is only applicable to POE products and lists the Type and Class of POE utilized.
- **“POE Connection”**: This field is exclusively for POE products to indicate whether the product connects directly or indirectly to the POE network—for example, whether a luminaire connects directly to the POE network, or indirectly through another luminaire or driver that is connected to the POE network.



21 Modular Products with External Power Supplies

21.1 Introduction

Refrigerated- and display-case lighting products are generally understood to separate the light engine and driver (i.e., external power supply) and are sold as systems with multiple LED modules attached to a power supply. While similar to DC-powered or POE products in design, these products are not considered DC-powered or POE and must comply with the requirements described within this section.

Unless otherwise noted, all DLC Standard, Premium, and LUNA program requirements remain applicable in addition to the thresholds and testing requirements specified in this section. Requirements in this section are unchanged from SSL V5.1.

21.2 Modular Products With External Power Supplies

The DLC understands that most refrigerated- and display-case lighting products are sold as systems with multiple units attached to a power supply. Occasionally, this system architecture has also been seen on other product types as well. DLC does not consider these as DC or POE products. For these products, there is no provision for qualifying a product to the DLC QPL with an unspecified or field-specified driver. Qualifications and listings are always driver-specific. If a specific driver is not sold with the product, model numbers will include tested driver information on the QPL, and tested performance shall be measured and reported with a driver that the listed product is intended to be used with within the field.

The DLC lists these products, when qualified, with module-level performance data for light output characteristics. Individual modules connected alone on the same power supply as used in the system are understood to not perform the same as they would when the total system is connected to the power supply because of efficiency variance based on the load on the power supply. Therefore, DLC evaluates and lists metrics where driver loading plays a meaningful role (i.e., efficacy and power quality metrics) at the system-level, including appropriately loaded power supplies. (For information on minimum required testing, see [Minimum Testing Requirements: Modular Products.](#))

For listing purposes, DLC will also include information in the “Notes” field on the QPL for end users, to describe the minimum system size necessary to meet DLC requirements, as based on the information provided in the application materials.



Part VI: Minimum Testing and Reporting Requirements and Additional Guidance for Demonstrating Compliance to Parts II Through V

Part VI specifies DLC’s minimum testing and reporting requirements for eligible PUDs to satisfy the performance threshold requirements outlined in Parts II through V. These requirements include guidance on identifying worst-case products within a family grouping for each type of threshold metric, lamp and retrofit kit testing, alternative testing procedures for large or long products that cannot be accommodated in standard photometric testing equipment, and testing and reporting requirements for alternatively sourced LEDs and drivers. In addition, Part VI establishes further requirements related to the submission of test reports and supporting documentation, such as IES files and SPD documents.



22 Lamps and Reference Housing Requirements

22.1 Introduction

SSL V6.0 provides performance requirements for certain types of eligible lamps to be listed on the SSL QPL. Some lamps (such as four-pin base replacement lamps for CFLs and mogul screw-base HID replacement lamps with luminaire-level requirements) are required to be tested in reference housings to provide luminaire level tests. Other lamps (such as linear replacement lamps, medium screw-base omnidirectional and directional replacements for HID lamps, and mogul screw-base omnidirectional and directional replacements for HID lamps) require lamp-level testing.

Requirements for linear replacement lamps and four-pin replacement lamps for CFLs are unchanged from SSL V5.1. Medium screw-base omnidirectional and directional replacements for HID lamps, and mogul screw-base omnidirectional and directional replacements for HID lamps are new to SSL V6.0 and have new testing requirements. Unless otherwise noted, all DLC Standard, Premium, and LUNA program requirements remain applicable in addition to the thresholds and testing requirements specified in this section. Pre-approved Equivalent Luminaires and Ballasts

22.2 Pre-approved Equivalent Luminaires and Ballasts

The DLC does not endorse or exclude any make or model of reference luminaire. The options listed in the [Approved Reference Housings for testing of LED Retrofit Kits and Lamps](#) are intended to illustrate common luminaires of each type. Manufacturers may test in alternative luminaires to those listed, with pre-approval from the DLC.

Pre-approved luminaires and ballasts must meet the following conditions:

- Alternative luminaires and ballasts must be commonly used in the General Application category intended to be applied for. Documentation may be required to demonstrate a luminaire's appropriate use if questions arise.
- Alternative luminaires and ballasts must provide similar thermal and electrical environments to those listed under each category below. Particularly, alternative luminaires may not be significantly different in internal volume or construction materials. Evaluation will not be made against the list of pre-approved equivalents. Alternative ballasts must be commonly used in the intended field use designation. In particular, alternative ballasts must be consistent in intended wattage, ballast factor, efficiency, and power quality under consistent loading conditions. Documentation may be required to demonstrate a ballast's intended use.
- To request that a luminaire and/or ballast be considered as a pre-approved equal for testing purposes, the specification sheet for the luminaire and/or ballast should be sent to

applications@designlights.org, along with a specification sheet for the replacement lamp. DLC review staff may need additional details, depending on the request and details available on the specification sheet.

22.3 Luminaire Level Tests

Lamps need to be tested in only one of the approved luminaires or a pre-approved equivalent. An LM-79, ISTMT, or IES file from the test must be supplied. (Please refer to the Reference Housings details below for detailed guidance on luminaire-level testing in appropriate reference housings.)

For all eligible lamp product categories other than Type A and Type B lamps, which are exempt from the driver lifetime requirements, in-situ temperature measurement testing (ISTMT) shall be conducted in the most restrictive thermal environment for which the product is rated, per its safety certifications (e.g., UL/CSA 1993), to be evaluated against lifetime requirement thresholds. That is, ISTMTs for DLC submission shall be conducted in the same thermal environment and use the same apparatus as is used by the safety organizations for evaluation of thermal performance in safety testing. ISTMTs will be reviewed to ensure that the safety standard is referenced and that the apparatus used is specifically noted or described in the test report. TM-21 projections will use this thermal measurement in conjunction with the provided LM-80 data and driver lifetime per the reported specification sheet to evaluate lumen maintenance and driver lifetime.

22.4 Mogul Screw Base (E39, E40) HID Replacement Lamps Tested in Reference Housings

The following information describes testing requirements for mogul screw-base HID replacement lamps tested in “reference” luminaire housings that meet SSL V6.0 technical requirements. For testing purposes, DLC specifies typical “reference” luminaire housings for mogul screw-base HID replacement lamp products to be tested in. This is done to provide testing results under common conditions in which the mogul screw-base HID replacement lamps would be installed. In providing this list of typical luminaire housings, DLC does not endorse or exclude any particular make or model frame for use in energy efficiency programs. It is important to note that in each recommended variation, an option for testing in a “Pre-approved Equivalent” is available. Some approved housings can come with medium or mogul sockets. For the purpose of DLC testing, the luminaire housing with the mogul socket must be used.

All test reports, including LM-79 and ISTMT test reports, must directly state the reference luminaire used for testing, including the complete model number and (where necessary) the specific socket type contained within the luminaire.

In selecting a luminaire for testing, the applicant shall consider the purpose for subjecting the tested lamp to extreme confinement for thermal endurance. If a product demonstrates necessary performance in a given luminaire, the product will be considered qualified in that luminaire and in luminaires of similar types and applications, only. The product will not be considered generically qualified, nor

qualified in other applications, unless the product is tested, demonstrates necessary performance, and is also listed on the DLC QPL in that application.

The reported data in an Application Form must be representative of the tested configuration, in other words, the reported data is based on lamp performance in the reference housing.

22.5 Four Pin-Base Replacement Lamps for CFLs

The following information describes testing requirements for four pin-base replacement lamps for CFLs that meet SSL V6.0 technical requirements.

The DLC accepts SSL QPL applications for four-pin base replacement lamps, including all G24q- and GX24q-base lamps and 2G11-base lamps greater than or equal to 20 inches in MOL. At this time, G24q, GX24q, and 2G11 UL Type A lamps (designed to operate utilizing the existing CFL ballast), 2G11 UL Type B (designed to operate utilizing direct line voltage), 2G11 UL Type C (designed to operate utilizing a non-integral driver), and 2G11 UL dual-mode (designed to operate utilizing the existing CFL ballast or direct line voltage) are all eligible. Dual mode lamps are not eligible.

G24q and GX24q UL Type B lamps and UL Type C lamps, as well as products with other bases (including 2-pin products), remain under consideration for future development. It should be noted that due to testing considerations, at this time, only products that can operate utilizing specific ballast types are eligible. (Please see testing requirements in Section 22.5.1 .) Replacement lamps designed to operate utilizing magnetic ballasts, or types of electronic ballasts that are not specified, are not eligible at this time.

The testing and reporting requirements described below are intended to subject the lamps to conditions found in typical luminaires to ensure confidence in performance.

For testing purposes, the DLC specifies typical reference luminaire housings for lamp products to be tested in, as well as reference ballasts to be included in testing. This is so that testing results provided and used in evaluation of the product are similar to common installed conditions. In providing this list of typical luminaire housings and ballasts, the DLC does not endorse any particular make or model for use in energy efficiency programs. It should be noted that in each recommended housing variation, an option for testing in a “Pre-approved Equivalent” is available for applicants to propose an alternative housing.

For the purposes of the Four-Pin Base Replacement Lamps for the CFL category, if a product demonstrates necessary performance in a given pre-approved luminaire and reference ballast, the product will be considered qualified generally.

22.5.1 Compatibility Tests for CFL Replacement Lamps

Due to concerns of compatibility of LED lamps with existing CFL ballasts, the DLC requires that lamps undergo system-level testing on a variety of ballasts to demonstrate compatibility.

It is important to note that the DLC may seek to evolve compatibility testing requirements as appropriate, based on experience and demonstrated need to assess products in the market.

The DLC requires all lamps for which qualification is applied for, to undergo testing as per the ENERGY STAR® requirements for frequency. These requirements are found Section 11.3 of [the ENERGY STAR Lamps V2.0 Specification](#) and are reproduced in [Table 34](#) for reference.

Table 34: Compatibility Testing Requirements: G24q- and GX24q-Base Lamps

Requirement	Methods of Measurement and/or Reference Document	Testing Guidance
Lamp light output shall have a frequency of ≥ 120 Hz	<p>Method of Measurement: None</p> <p>Reference Document: IEEE Std 1789™- 2015</p>	<p>Sample Size: One unit per model.</p> <p>Light output waveform shall be measured with a photodetector with a rise time of 10 microseconds or less, transimpedance amplifier, and oscilloscope. Employed equipment models and methods of measurement shall be documented. Temporal response, amplification, and filtering characteristics of the system shall be suitably designed to capture the photometric waveform. Digitized photometric waveform data and an image of the relative photometric amplitude waveform shall be recorded. Measured data shall be recorded to a digital file with an interval between each measurement no greater than 0.00005 sec (50 microseconds), corresponding to an equipment measurement rate of no less than 20 kHz and capture at least 1 second of data.</p>

The lamp must be tested and results documented according to [Table 34](#) on each of the following ballast types:

- Philips ICF-2S18-HI-LD
- Philips ICF-2S26-HI-LD
- OSRAM/Sylvania QTP1/2x18CF/UNV
- OSRAM/Sylvania QTP2x26CF/UNV
- Triad C218UNVBE or Triad C218UNVME
- Triad C2642UNVBE or Triad C2642UNVME
- Fulham NPY-120-226-CFL
- Robertson RED1L10-120

Requests for Pre-approved equivalents will *not* be accepted for compatibility testing purposes.

22.6 Other Categories Tested in “Reference” Housings

For retrofit kits, certain General Applications of mogul screw-base (E39, E40) replacements for HID lamps, and G24q-base replacement lamps for CFLs, the DLC will continue using reference housing testing as a necessary means to evaluate the performance of these products in a typical end use. To address availability concerns, both the pre-approved equivalent provisions and the “Option B” pathway for luminaire-specific retrofit kits remain in place. Additionally, the DLC periodically reviews public sources to check that the housings listed [on the DLC Approved Housing webpage](#) appear to be available on the market. In cases where they do not appear to be available, the DLC will continue to evaluate alternative housings and add them to the acceptable reference housing list. The DLC does not endorse any particular manufacturer associated with particular reference housings listed as part of these policy provisions.

Performance requirements (e.g., for light output, efficacy, color) for these products remain otherwise as described in other sections of this Technical Requirements document.

22.7 Testing and Reporting Requirements for Linear and 2G11-Base Replacement Lamps; and Mogul and Medium Screw-Base Replacement Lamps

This section provides the testing and reporting requirements for linear replacement lamps, 2G11-base replacement lamps for CFLs, and mogul screw-base (E39, E40) and medium screw base (E26, E27) omnidirectional and directional replacements for HID lamps under SSL V6.0. [Table 35](#) provides information on the reference ballasts required for LM-79 testing of Type A and Dual Mode Type A/B linear replacement lamps.

Linear replacement lamps, 2G11-base replacement lamps for CFLs, and omnidirectional and directional replacements for HID lamps (both medium screw-base [E26, E27] and mogul screw-base [E39, E40]) do not have to be tested in reference housings for luminaire-level tests.

Table 35: Type A and Dual Mode Reference Ballast Criteria

Type A and Dual Mode Reference Ballast Criteria	
General Applications	Reference Ballast for Type A and Dual Mode Type A/B
T8 Linear Replacement Lamps	T8 electronic instant-start ballast with 0.88 ballast factor
T5 and T5HO Linear Replacement Lamps	T5/T5HO electronic programmed-start ballast with 1.0 ballast factor

For Type-B and Type-C products (i.e., lamp-style retrofit kits, which connect mechanically and/or electrically to the fixture via standard lamp holders, but which require an electrical modification to the existing fixture), lamp-level testing is required.



In addition to full LM-79/Color reports for worst-case light output, worst-case efficacy, and appropriate color properties per the rules applicable to all products, submitters shall provide a full LM-79/Distribution (goniophotometer) test for each optical variation (including lens variations) of a lamp product without consideration of lumen package and the effect of color properties, tested at the maximum (non-dimmed) light output, and the IES file derived from the LM-79 test data, for the purposes of evaluating the beam angle. Full LM-79/Color reports and full LM-79/Distribution reports must conform to [Additional Requirements for LM-79, LM-80, and TM-21 Test Reports](#).

For all linear replacement lamps (including child products), as well as mogul screw-base and medium screw base omnidirectional and directional replacements for HID lamps, the beam angle shall be reported in the Reported Performance Table on the application form.

22.7.1 Type A, Type A/B, and Type C Systems Testing With Multiple Lamps

If the system is designed to operate multiple lamps utilizing an external driver, the driver should be loaded as it would be in the field, with appropriate steps taken to calculate the efficacy of the single lamp. For example, for a two-lamp kit, one lamp should be measured for light output, while the system as intended (with two identical lamps on the driver) should be measured for electrical input. The wattage into the driver can then be divided by two, and the lamp lumens divided by that wattage to determine system efficacy.

Appropriate steps to measure the electrical and photometric properties of the lamp system, under most circumstances, would be to load the driver or ballast appropriately, then isolate a single lamp in the apparatus being used for photometric measurements. In a sphere, for example, this could be accomplished by placing one lamp from the system inside the sphere while the other one is outside the sphere.

22.7.1.1 Type C Lamp Requirements

Multi-lamp Type-C lamp systems are, in general, expected to have multiple lamps of the exact same type. For multi-lamp Type-C systems where the lamps within the system are not identical, the following restrictions and testing rules apply:

- Lamps within the Type-C system may only differ for purposes of allowing enhanced communications or control features. Lamps with explicitly different performance, such as nominally different color temperatures or light outputs, are not eligible to be listed in a Type-C system.
- Lamp-level testing must show consistency between lamps in terms of light output, efficacy, and wattage within $\pm 10\%$. Products must also be of the same nominal CCT and CRI.
- Each of the distinct lamps in the system must have its own lamp-level testing.
 - The appropriate number of multiple lamps of the same type should be loaded onto the driver, and lamp-level lamp testing conducted according to the “Testing Notes” section below.
- QPL listings in the “Model Number” field must be of one of the following forms:



- If each lamp and the associated driver in the system has a distinct product identifier (model number or other unique identifier), the distinct product identifiers will be noted in the model number field with the lamp quantity (“N”) for each lamp model in the system as: (Lamp A, Lamp B,... Lamp N)(Driver).
- In a system with more than two lamps, model numbers will be represented as follows:
 - Lamp A (one), Lamp B (“N”), (Driver)
For example, a 4-lamp system will be represented as “Lamp A (one), Lamp B (three), (Driver)”
- Alternatively, if the system is sold as one unified system under a single distinct product identifier, that identifier will be listed in the Model Number field: (System Ordering Code) o Test data and reported data on the QPL listing will reflect the worst-case efficacy lamp. A note placed in the Notes field will clarify that the data represents lamp-level data for the worst-case lamp in the system.



23 Retrofit Kits Testing

23.1 Introduction

The DLC allows two types of retrofit kits to be listed on the SSL QPL—integrated retrofit kits and certain linear style retrofit kits. Requirements in this section specify the testing and reporting requirements for these product types. They include luminaire housing requirements, testing, and reporting requirements. Unless otherwise noted, all DLC Standard, Premium, and LUNA program requirements remain applicable in addition to the thresholds and testing requirements specified in this section. Requirements in this section are unchanged from SSL V5.1.

23.2 Testing and Reporting Requirements for Retrofit Kits

Manufacturers have two options for testing retrofit kits:

- **Option A:** Testing in [Approved Housings](#)
- **Option B:** Testing in a manufacturer-selected housing

23.2.1 Option A: Testing in Approved Housings (General Purpose)

Option A is intended for retrofit kits that are designed to retrofit typical incumbent luminaires. The testing and reporting requirements described below are intended to subject retrofit kits to conditions in typical luminaires in order to ensure confidence in performance.

For this option, the DLC specifies typical luminaire housings for the testing of retrofit products, referred to as Approved Housings. This is done to provide test results under common conditions in which the retrofit kits may be installed. In providing this list of typical luminaire housings, the DLC does not endorse or exclude any particular make or model frame for use in energy efficiency programs. In selecting a luminaire for testing, the manufacturer shall consider the purpose for subjecting the tested kit to typical confinement for thermal endurance.

Retrofit kits tested in an approved housing are considered qualified when installed in any housing of the same end-use. For example, a shoe-box style retrofit kit tested in the Lithonia KAD Contour Series approved housing would be considered qualified (should it meet all technical requirements) when installed in any situation applicable to the “Retrofit Kits for Outdoor Pole/Arm-Mounted Area and Roadway Luminaires” Primary Use Designation. If a retrofit kit can be used in multiple Primary Uses, manufacturers will need to provide testing in a housing applicable to each Primary Use in order to be considered qualified in those end uses. Products tested according to Option A will be designated as "General Purpose" on the QPL.

- **Required Tests and Reports**

All DLC QPL testing and reporting requirements that apply to new luminaires shall also apply to

any retrofit kit application. This could include, for example, LM-79 and ISTMT reports, IES files, and TM-21 projections. (Note that for lumen maintenance testing, the source manufacturer is responsible for the LM-80 test of the LED package, array, or module. A report resulting from this test must be passed on to the DLC by the applicant, as specified in the application instructions.)

- **Luminaire-Level Tests**

Retrofit kits must be tested (following, for example, LM-79, ISTMT, LM-80, and/or LM-84) in a fully functional manufacturer-selected reference luminaire from the approved list, with the kit properly installed per the manufacturer's instructions.

As noted previously, the DLC does not endorse or exclude any particular make or model of reference luminaire. The options listed are intended to illustrate common luminaires of each type. Manufacturers may test in alternative luminaires to those listed, with pre-approval from the DLC.

Applicants shall test and report luminaire performance under the following restrictions and conditions:

- Alternative luminaires must be commonly used in the intended application category. Documentation may be required to demonstrate a luminaire's appropriate use if questions arise.
- Alternative luminaires may not be significantly different in internal volume or construction materials. (*Note: Pre-approved equivalent requests will only be evaluated against the approved luminaires listed in Section 23.2*) Evaluation will not be made against the list of approved housings.

To request that a luminaire be considered as an approved housing for testing purposes, the specification sheet for the luminaire should be sent to applications@designlights.org, along with a specification sheet for the retrofit kit product. DLC review staff may need additional details, depending on the request and details available on the specification sheet.

23.2.2 Option B: Testing in Manufacturer-Selected Housing (Luminaire Specific)

The DLC understands that not all retrofit kits are designed for the typical housings described in Section 23.2.1 (Option A testing). If a retrofit kit is designed for a specific housing that is not represented by the approved housings listed in Section 23.2 , and does not meet the conditions of the pre-approved equivalent process, manufacturers may select a different housing that is appropriate and representative of the housing in which the retrofit kit would be installed in the field.

Products tested via Option B are only considered qualified when installed in the specific type of housing used for testing. Additional testing in each applicable type of housing will be required if manufacturers would like to have a retrofit kit considered qualified when installed in multiple types of housings under Option B. If a housing type has multiple variations (e.g., with or without lenses), testing must be conducted with the variation that results in the worst-case condition. The specification sheet for the housing used for testing will be reviewed during the Initial Review process to ensure that the housing is still within the intended use of the currently available retrofit kit Primary Use Designations.

The DLC will determine if a retrofit kit is designed for a specific housing by reviewing the marketing material (i.e., product specification sheet) associated with the retrofit kit. Product specification sheets must clearly indicate which specific type of housing the retrofit kit is intended for. The DLC review process may include checking the web listing and other marketing materials. DLC reserves the right to request additional information to demonstrate the retrofit kit is only designed for a specific housing type, if product specification sheets are not sufficient.

Products tested according to Option B will be designated as “Luminaire Specific” on the QPL, with the housing used for testing listed in the Notes field.

Manufacturers shall test and report luminaire performance under the following restrictions and conditions:

- **Required Tests and Reports**

All DLC QPL testing and reporting requirements that apply to new luminaires shall also apply to any retrofit kit application. This could include, for example, LM-79 and ISTMT reports, IES files, and/or TM-21 projections. (Note that for lumen maintenance testing, the source manufacturer is responsible for the LM-80 test of the LED package, array, or module. A report resulting from this test must be passed on to the DLC by the applicant, as specified in the application instructions.)

- **Luminaire-Level Tests**

Retrofit kits must be tested (following, for example, LM-79, ISTMT, LM-80, and/or LM-84) in a fully functional manufacturer-selected reference luminaire with the kit properly installed per the manufacturer’s instructions.

23.3 Special Considerations for Unique Retrofit Kit Scenarios

For scenarios where the same product can be sold as a retrofit kit or a luminaire:

The exact same product must be able to be deployed as either a standalone luminaire or as a retrofit kit. In other words, the same product could be installed in either an existing host housing (i.e., as a retrofit kit) or directly in the space without a host housing (i.e., as a luminaire).

The product (or related group of products) can be submitted as a family in a single Level 2 application, with the product(s) for which qualification is sought in both the appropriate luminaire PUD and the appropriate retrofit kit PUD.

To be considered for qualification in both PUDs, the product(s) must appear on the application form twice, one line corresponding to the luminaire PUD and the other corresponding to the retrofit kit PUD. If the product(s) pass review, they will appear on the QPL under two listings and with different Product IDs, corresponding to each PUD.

All testing must be conducted with the product as a retrofit kit installed in one of the approved housings (Option A within the retrofit kits policy), as this installation method will commonly result in a higher



temperature for the product and less efficient performance—thus, the worst-case condition for testing. For products intended for luminaire-specific housings (Option B within the retrofit kits policy), the submitting manufacturer will need to ensure compliance with the provisions of that pathway and test in the target reference housing as described in Section **23.2.2** (Option B).



24 Minimum Testing Requirements

24.1 Introduction

As many of the Technical Requirements in SSL V6.0 and LUNA V2.0 are minimum performance threshold requirements, demonstrating that the worst-case models within a family group meet these requirements implies that models performing better than the worst-case models will also meet the requirements.

This section specifies the minimum testing required to demonstrate compliance with SSL V6.0 and has the same testing requirements as SSL V5.1, with the exception of the required ISTMT for SSL V6.0 SSL products.

24.2 Demonstrating Compliance With SSL V6.0 and LUNA V2.0

All luminaires, retrofit kits, and lamp products tested to meet DLC threshold requirements are to be tested per ANSI/IES LM-79 physical and environmental test conditions (e.g., ANSI/IES LM-79-24 Section 4.0). Unless otherwise indicated, testing to demonstrate compliance can be conducted on one sample per metric as described in Table 36. Testing shall be conducted with the sample at its maximum (non-dimmed) light output. The DLC reserves the right to ask for additional information as needed.

Table 36 describes the minimum testing required for all OEM product applications under SSL V6.0. Additional information on how to demonstrate compliance to technical requirements and how these apply to families of products can be found in the [Level 2 \(formerly family grouping\) application requirements](#).

Table 36: Required Testing to Demonstrate Compliance With SSL V6.0 and LUNA V2.0

Metric	Tested Models	Required Test
Minimum Light Output	Worst-case light output	Full LM-79/Color report, including accompanying SPD document
Minimum Efficacy	Worst-case efficacy	Full LM-79/Color report, including accompanying SPD document
Maximum CCT	Highest CCT in family at lowest color rendition option	Full LM-79/Color report, including accompanying SPD document
Minimum CCT	Lowest CCT in family at lowest color rendition option	LM-79/Color report, including accompanying SPD document



Metric	Tested Models	Required Test
Minimum Color Rendering	Lowest color rendition option in family	LM-79/Color report, including accompanying SPD document
Chromaticity	<ul style="list-style-type: none"> • Lowest CCT at lowest color rendition option • Highest CCT at lowest color rendition option • Lowest CCT at highest color rendition option (Premium only) 	Full LM-79/Color report, including accompanying SPD document
Minimum L ₇₀ Lumen Maintenance for Standard and L ₉₀ for Premium	<ul style="list-style-type: none"> • ISTMT at worst-case thermal conditions of LED • LM-80 for single LED package/module/array as required for lumen maintenance projection 	ISTMT, LM-80, LM-84, TM-21, TM-28
Color Maintenance	LM-80 for single LED package/module/array that is evaluated for color shift	LM-80, LM-84
Driver Lifetime (Premium only)	Worst-case driver temperature for each unique driver	Driver spec, ISTMT
Zonal Lumen Distribution (ZLD), Spacing Criteria (SC)	Each unique optical and distribution pattern	Tested LM-79/Distribution report, including accompanying IES file
BUG Ratings (outdoor luminaires and retrofit kits only, excluding lamps)	Each unique optical and distribution pattern	Tested LM-79/Distribution report, including accompanying IES file
UGR (Specific Indoor PUDs and Premium Only)	Each unique optical and distribution pattern at the highest lumen output without consideration of the effect of color properties	Tested LM-79/Distribution report, including accompanying IES file
THD, PF	Worst-case performing driver in family	Benchtop Electrical Testing

24.2.1 Minimum Testing Requirements: DLC Standard Light Output and Distribution

The light distribution test reports required to qualify products to the DLC SSL QPL under the Standard classification areas follows:

- A full LM-79/Distribution report and IES file, per the [Additional Requirements for LM-79, LM-80, and TM-21 Test Reports](#), shall be provided for each unique distribution pattern in the family, without consideration of the lumen package or the effect of color properties,⁷ tested at the maximum (non-dimmed) light output.
 - For indoor or outdoor Level 2 applications, products chosen for goniophotometric testing may be at any CCT and any light output.
- Zonal lumen distribution (ZLD), spacing criteria (SC), beam angle (linear replacement and 2G11-base lamps only), and BUG ratings (outdoor luminaires and retrofit kits only, excluding lamps) will be verified using the IES files associated with the full LM-79/Distribution test reports.
- Reported data, including beam angle (linear replacement and 2G11-base lamps only) and BUG ratings (outdoor luminaires only, excluding lamps and retrofit kits), shall be reported in the Reported Performance Table tab on the application form.
 - The DLC review process will use [Photometric Toolbox](#) (Lighting Analysts, Inc., version 2.14 or newer) to verify ZLD, SC, beam angle, and BUG ratings (outdoor luminaires only, excluding lamps and retrofit kits) using the submitted IES file.

Products under the Standard classification for which efficacy allowances are sought based on meeting the maximum UGR thresholds in Table 21 shall include the following additional materials:

- A full LM-79/Distribution report, per the [Additional Requirements for LM-79, LM-80, and TM-21 Test Reports](#), for the products that have the highest total lumen output for each optical variation in the family, without consideration of the effect of color properties,⁸ tested at the maximum (non-dimmed) light output; and the IES file based on the LM-79 test data.
- Indication on the application form which UGR bin the product's Corrected UGR value falls in. If the product has a UGR less than 10.0, it will fall in the 10.0-12.9 bin.
- Qualification for UGR efficacy allowances is verified by the application reviewer using the Corrected UGR table in [Photometric Toolbox](#) (Lighting Analysts, Inc., version 2.14 or newer), generated from the submitted tested IES file. If the values in the UGR table for the glare evaluation reference condition (room dimension: X = 4H, Y = 8H; spacing to height ratio: 1;

⁷ The color properties, such as CCT and color rendition, of the indoor products within the product family used for the LM-79/Distribution test may be of the applicant's choice, and the tested configuration may be the same configuration used to meet other technical requirements if applicable.

⁸ The color properties, such as CCT and CRI, of the product within the product family used for the LM-79/Distribution test may be of the applicant's choice.

reflectances: 70%/50%/20%) meet the requirements in [Table 18](#), both endwise and crosswise, the product, or family of products in the case of Level 2 applications, qualifies for the efficacy allowance.

24.2.2 Minimum Testing Requirements: DLC Standard Spectral Quality

This section describes the test reports related to spectral quality that are required to qualify products to the DLC SSL QPL under the Standard qualification.

24.2.2.1 Color Rendition and Chromaticity (CCT and D_{uv}): DLC Standard

The DLC has several pathways for demonstrating color rendition and chromaticity compliance, depending on the level of product-variation complexity. In the pathways described below, “option” (color rendition or CCT) is used to describe a specific, nominal performance variation in a given set, for a product or product family.

Additionally, all color rendition options shall meet or exceed either the ANSI/IES TM-30 color rendition requirements (Option 1) or the CIE 13.3.-1995 color rendition requirements (Option 2), and both sets of color rendition measures shall be measured and reported.

- **For product families that offer one color rendition option and one or more CCT options:** A full LM-79/Color report, per the [Additional Requirements for LM-79, LM-80, and TM-21 Test Reports](#), shall be provided at the lowest and highest CCT options offered.
- **For product families that offer one or more color rendition option(s) and one CCT option:** A full LM-79/Color report, per the [Additional Requirements for LM-79, LM-80, and TM-21 Test Reports](#), shall be provided at the minimum color rendition option for the CCT option offered.
- **For product families that offer one or more color rendition option(s) and one or more CCT option(s):** A full LM-79/Color report, per the [Additional Requirements for LM-79, LM-80, and TM-21 Test Reports](#), shall be provided for the lowest and highest CCT options offered, at the minimum color rendition option.

The DLC also requires that testing be conducted on the worst-case efficacy variation, which is likely the combination of lowest CCT and highest color rendition. If the overall minimum color rendition option was not captured in any LM-79/Color report described above, this configuration must be tested.

In all cases, testing requirements correspond to technical requirements by classification (DLC Standard or Premium) in addition to product options. See [Testing Guidance for Color Metrics](#). For example, if a family includes multiple color rendition options, only some of which are eligible [Efficacy Allowances](#), testing would be required at the worst-case (efficacy) color rendition option *that meets the allowance*

requirement, for the subgroup of products for which the allowance is sought, and the minimum color rendition *overall* for the remainder of the group.

24.2.2.2 Color Maintenance: DLC Standard

The DLC has two pathways for demonstrating color maintenance compliance:

- **Color Maintenance Option 1:** An LM-80 report for each LED package, module, or array used within the product shall be provided and shall include chromaticity data for at least approximately 1,000-hour and approximately 6,000-hour time intervals. If the LM-80 report uses uneven test intervals, the closest measurement points below the 1,000-hour measurement point (<1,000 hours) and beyond the 6,000-hour measurement point (>6,000 hours) will be referenced for evaluation of color maintenance. Additionally, color maintenance will be evaluated against the appropriate LM-80 55° C data set, or the lowest temperature data set provided that is greater than 55° C, if there isn't a 55° C data set available. An appropriate LM-80 data set will be tested at a drive current at or above the drive current utilized for the TM-21 calculations on submitted product(s).
- **Color Maintenance Option 2:** Luminaire-level performance data that follow LM-84 test procedures for the product shall be provided and shall include chromaticity data for at least approximately 1,000-hour and approximately 6,000-hour time intervals.

Due to the length of this type of testing, it is recommended that the submitter contact the DLC at applications@designlights.org to ensure that the testing plan will align with DLC Testing and Reporting Requirements before beginning any testing using the LM-84 method.

In the case that average chromaticity coordinate data at the approximately 1,000-hour and approximately 6,000-hour measurement points are not provided and only chromaticity shift ($\Delta u'v'$) data is available, the DLC will assume the worst-case shift between these two measurement points. To clarify, the DLC will assume that the approximately 1,000-hour and approximately 6,000-hour measurement points represent color shifts in opposite directions and will sum the two reported chromaticity shift values to ensure that the worst-case shift meets the appropriate color maintenance requirement.

Additionally, to move toward color maintenance reporting based on consensus-based industry-developed standards, SSL V6.0 allows optional reporting of CS4 and CS7 values (in hours) per [ANSI/IES TM-35-19](#). These values rely on existing LM-80 and/or LM-84 chromaticity data and will be reported on the QPL with the listed product. While no thresholds are stipulated in SSL V6.0, it is intended that future SSL technical requirement revisions will introduce thresholds based on analysis of CS4 and CS7 data collected and will remove the existing color maintenance thresholds described in Option 1 and Option 2 above.

24.2.2.3 Interactions With Other DLC Requirements: Color-Tunable Products and Field Adjustable Light Output (FALO) Products



For *Color-Tunable Products* and/or Dimmable and *Field Adjustable Light Output (FALO)* products, additional clarifications on meeting the SSL V6.0 spectral quality requirements are as follows:

- For color-tunable products, testing and reporting requirements for chromaticity (CCT and D_{uv}), color rendition, and color maintenance are applicable, unless specifically excluded.
- For parent products in a Level 2 application, the tested chromaticity (CCT and D_{uv}) and color rendition at the CCT setting required by the Color-Tunable Testing and Reporting Requirements will be listed on the QPL. D_{uv} will not be reported or listed for child products.
 - Color maintenance will be evaluated for each unique LED within a product that uses separate LM-80 data.
 - CCT-Tunable and Full Color-Tunable products shall test and report at the minimum, maximum, and mid-point eligible CCT settings.
 - Full Color-Tunable products are not required to meet the chromaticity requirements in SSL V6.0.
- For dimmable and/or FALO products, testing and reporting requirements for chromaticity (CCT and D_{uv}), color rendition, and color maintenance are applicable and are evaluated at the maximum light output setting. For parent products in a Level 2 application, chromaticity (CCT and D_{uv}) and color rendition will be listed on the QPL under the Tested Data section. For child products, reporting of CCT and all color rendition measures is required, and all information will be listed on the QPL as Reported Data.
- Dimmable and FALO products will not be evaluated for chromaticity (CCT and D_{uv}), color rendition, or color maintenance at dimmed output settings.

24.2.3 Minimum Testing Requirements: Spectral Quality for Efficacy Allowances

To qualify for efficacy allowances, applications shall include the following additional materials:

- A full LM-79/Color report, per the *Additional Requirements for LM-79, LM-80, and TM-21 Test Reports*, for the worst-case (efficacy) color rendition option and the minimum color rendition overall of the group for which an efficacy allowance is sought.
 - All color rendition options shall meet the color rendition requirements, and *both* sets of color rendition measures (IES TM-30 and CIE 13.3) shall be measured and reported.
- In all cases, testing requirements correspond to Technical Requirements levels, in addition to product options. For example, if a family includes multiple color rendition options, only some of which are eligible for an allowance, testing would be required at the worst-case (efficacy) color rendition option *that meets the allowance requirement*, for the subgroup of products for which the allowance is sought, and the minimum color rendition *overall* for the remainder of the group.

24.2.4 Minimum Testing Requirements: DLC Premium Light Distribution

The lighting distribution and discomfort from glare test reports required to qualify products under the Premium qualification are as follows, for all tested products for distribution:

- A full LM-79/Distribution report, per the [Additional Requirements for LM-79, LM-80, and TM-21 Test Reports](#), for each optical variation within the family, without consideration of the lumen package or the effect of color properties,¹² tested at the maximum (non-dimmed) light output; and the IES file based on the LM-79 test data
- ZLD, SC, UGR, and BUG ratings (outdoor luminaires and retrofit kits only, excluding lamps) will be verified using the IES file associated with the full LM-79/Distribution test report
- The required data, including BUG ratings (outdoor luminaires and retrofit kits only, excluding lamps), shall be reported on the application form.
- DLC reviewers will use [Photometric Toolbox](#) (Lighting Analysts, Inc., version 2.14 or newer) to verify ZLD, SC, UGR (Premium and Efficacy Allowance pursuance), beam angle, and BUG ratings (outdoor luminaires and retrofit kits only, excluding lamps) using the submitted IES file.

24.2.4.1 Discomfort from Glare: DLC Premium

The DLC Premium discomfort from glare requirements are only applicable to Troffer products within the eligible luminaire and retrofit General Applications. Submitted applications shall include the following additional materials:

- A full LM-79/Distribution report, per the [Additional Requirements for LM-79, LM-80, and TM-21 Test Reports](#), for the products that have the highest total lumen output for each optical variation in the family, without consideration of the effect of color properties,⁹ tested at the maximum (non-dimmed) light output; and the IES file based on the LM-79 test data.
- Indication on the application form which UGR bin the product's Corrected UGR value falls in. If the product has a UGR less than 10.0, it will fall in the 10.0-12.9 bin.

Qualification for Premium is verified by the application reviewer using the Corrected UGR table in [Photometric Toolbox](#) (Lighting Analysts, Inc., version 2.14 or newer), generated from the submitted IES file. If the values in the UGR table for the glare evaluation reference condition (room dimension: X = 4H, Y = 8H; spacing to height ratio: 1; reflectances: 70%/50%/20%) meet the requirements in [Table 21](#), both endwise and crosswise, the product, or family of products in the case of Level 2 applications, qualifies for the DLC Premium qualification.

⁹ The color properties, such as CCT and CRI, of the product within the product family used for the LM-79/distribution test may be of the applicant's choice.

24.2.5 Minimum Testing Requirements: DLC Premium Spectral Quality

A manufacturer seeking qualification of its product(s) to DLC Premium shall provide all the necessary testing to demonstrate that the product(s) meet the Premium requirements, in addition to meeting all Standard requirements.

In the pathways described below, “option” (color rendition or CCT) is used to describe a specific, nominal performance variation in a given set for a product or product family.

- In addition to the test report and implementation requirements for DLC Standard qualification, a full LM-79/Color report, per the [Additional Requirements for LM-79, LM-80, and TM-21 Test Reports](#), for the maximum color rendition option at the lowest CCT option, shall be provided.
 - For example, if a product family consists of two color rendition options (e.g., CRI $R_a = 80$ and $R_9 = 0$; and CRI $R_a = 90$ and $R_9 = 50$) and four CCT options (e.g., 2700 K, 3500 K, 4000 K, and 5000 K), and *all* variations are to be qualified to DLC Premium, a minimum of three LM-79 test reports shall be provided. That is, one test for the highest CCT at the minimum color rendition option, one test for the lowest CCT at the minimum color rendition option, and one test at the lowest CCT for the higher color rendition option.
- Consistent with the Standard qualification requirement, tested color rendition options shall meet either the ANSI/IES TM-30 color rendition requirements (Option 1) or the CIE 13.3-1995 color rendition requirements (Option 2), as described in
- [Table 4](#) and *both* sets of color rendition measures shall be measured and reported.
- The DLC also requires that testing be conducted on the worst-case efficacy variation, which is likely the combination of lowest CCT and highest color rendition.
- In all cases, testing requirements correspond to technical requirements levels, in addition to product options. For example, if a family includes multiple color rendition options, only some of which are eligible for an allowance, testing would be required at the worst-case (efficacy) color rendition option *that meets the allowance requirement*, for the subgroup of products for which the allowance is sought, and the minimum color rendition *overall* for the remainder of the group.

24.2.6 Minimum Testing Requirements: Discomfort Glare Efficacy Allowances

To qualify for the efficacy allowances, applications shall include the following additional materials:

- A full LM-79/Distribution report, per the [Additional Requirements for LM-79, LM-80, and TM-21 Test Reports](#), for the products that have the highest total lumen output for each optical variation



within the family, without consideration of the effect of color properties,¹⁰ tested at the maximum (non-dimmed) light output; and the IES file based on the LM-79 test data.

- Indication on the application form which UGR bin the product's Corrected UGR value falls in. If the product has a UGR less than 10.0, it will fall in the 10.0-12.9 bin.

The product's qualification for efficacy allowances is verified by the application reviewer using the Corrected UGR table generated in [Photometric Toolbox](#) (Lighting Analysts, Inc. version 2.14 or newer), from the submitted IES file. If the values in the UGR table for the glare evaluation reference condition (room dimension: X = 4H, Y = 8H; spacing to height ratio: 1; reflectances: 70%/50%/20%) meet the requirements both endwise and crosswise, the product qualifies for the allowances. In the case of a Level 2 application, all products of the same optical variations as the submitted luminaires within the family automatically qualify for the allowances.

24.2.7 Minimum Testing Requirements: LUNA Distribution

The lighting intensity distribution test reports required to list products under the LUNA qualification are as follows:

- A full LM-79/distribution report must be submitted in PDF format, per the [Additional Requirements for LM-79, LM-80, and TM-21 Test Reports](#), for the products that have the highest total lumen output for each optical variation across the LUNA family members with the highest qualifying CCT (e.g., 3000 K), tested at the maximum (non-dimmed) light output.
- An IES file, and optionally, an ANSI/IES TM-33-18 or -23 XML document, both based on the LM-79 test data, must be submitted along with the PDF distribution report.
- Product image(s) of the tested product showing the optics and shields, if applicable, must be included in the PDF distribution report. Product image(s) may be of the tested product on the bench, but not in the measuring equipment. Images will be used by reviewers to understand the product being tested and will not be published on the QPL.
- For tested products, threshold U ratings from the BUG ratings will be verified using the IES files associated with the full LM-79/Distribution test report.
- For all products where LM-79/Distribution reports are not required, reported data, including BUG ratings, must be reported in the reported values on the application form.
- The DLC review process will analyze the submitted IES files using Photometric Toolbox (Lighting Analysts, Inc., version 2.14 or newer) to verify BUG ratings and house-side or street-side lumens (for products pursuing shielding efficacy allowances) using the submitted IES photometric files.
- The DLC review process will evaluate drawings and text information on the submitted specification sheets and installation instructions to verify that the qualified mounting bracket

¹⁰ The color properties, such as CCT and CRI, of the product within the product family used for the LM-79/Distribution test may be of the applicant's choice, and the tested configuration may be the same configuration used to meet other technical requirements if applicable.

does not allow a tilt angle greater than 10 degrees. For products with permitted mounting options or accessories, the mounting bracket and related maximum tilt angle must be graphically shown on either the specification sheet or installation instructions (see [Figure 1](#)).

24.2.8 Minimum Testing Requirements: LUNA Spectral Quality

In addition to the test report and implementation requirements applicable to DLC Standard and Premium qualifications under SSL V6.0, the spectral quality test reports required to list products under the LUNA V2.0 qualification are as follows.

Within a product family, LUNA products are required to be tested and the following results reported:

- For product families that offer **one color rendition option and one or more CCT option(s)**: A full LM-79/Color report, per the [Additional Requirements for LM-79, LM-80, and TM-21 Test Reports](#), must be provided at the lowest and highest CCT options offered on LUNA qualifying products.
- For product families that offer **one or more color rendition option(s) and one CCT option**: A full LM-79/Color report, per the [Additional Requirements for LM-79, LM-80, and TM-21 Test Reports](#), must be provided at the minimum color rendition option for the CCT option offered on LUNA qualifying products.
- For product families that offer **one or more color rendition option(s) and one or more CCT option(s)**: A full LM-79/Color report, per the [Additional Requirements for LM-79, LM-80, and TM-21 Test Reports](#), must be provided for the lowest and highest CCT options offered, at the minimum color rendition option offered on LUNA qualifying products.
- For product families that offer one or more Amber LED options: A full LM-79/Color report, per the [Additional Requirements for LM-79, LM-80, and TM-21 Test Reports](#), must be provided for one representative pc-Amber, de-Amber, and Filtered Amber LUNA qualifying product(s), as appropriate.

All LM-79/Color tests for LUNA qualification may be conducted at any light output for at least one optical variation within the family when operating at the maximum (non-dimmed) light output. If providing TM-33 data, the XML document based on the LM-79 test data must include both spectral and luminous intensity distribution data, per the [Additional Requirements for LM-79, LM-80, and TM-21 Test Reports](#).

- For the product with the highest CCT, the TM-33 XML document must include both the emitter spectral data and the emitter luminous intensity data for a single tested product, if submitted.
- For the product with the lowest CCT, the TM-33 XML document may include only the emitter spectral data, without the emitter luminous data, for a single tested product, if submitted.

24.2.9 Minimum Testing Requirements: LUNA Shielding Efficacy Allowances

Manufacturers that choose to list LUNA qualified products with shields must test their products with shields as described below.



- Shields that are offered as options must have the shield indicated in the luminaire catalog or ordering code number and will be shown on the QPL as such.
- Shields that are offered as accessories must have the accessory listed in the luminaire catalog or ordering code number and will be displayed on the QPL in parentheses (e.g., “ABC-100W-30K80CRI-HA (with accessory HSS-Black)”, where “HA” is the nomenclature or ordering code for a horizontal arm, and “HSS-Black” is the nomenclature or ordering code for this shield accessory).
 - QPL performance and testing required on products with accessories included with the model number in the application will be treated as though the accessory is an option within the model number (i.e., performance information will reflect product performance with accessory attached; worst-case testing will include products with accessory attached).

If a manufacturer offers more than one configuration of a specific shield type (HSS, CSS, FSS), the variety of configurations under each shield type are treated as a shield type subgroup within the product family (e.g., an HSS subgroup could include internal and external HSSs, or an HSS subgroup could include a Type II HSS with a 30-degree shielding angle¹¹ and a Type II HSS with a 45-degree shielding angle). Each shielding option configuration will be listed as a separate reported family member, with the effect on the distribution and light output of the luminaire documented. If products are available with multiple shield colors, the shield color and/or finish must be specified in the model number, may not be listed as a wildcard option in the listing, and may not be combined, because lighter color shields will potentially reflect more light to the sky dome and might not meet the required U rating threshold for that PUD.

Table 37 provides an example of a luminaire family with various HSS and FSS options. The worst-case efficacy parent in each subgroup (HSS or FSS) is the product that results in the lowest efficacy, assuming that all HSS or FSS products in the subgroup meet the specified requirements (i.e., all HSS products reduce the house-side lumens by at least 50% compared to the unshielded equivalent product, and all FSS products reduce the street-side lumens by at least 30% compared to the unshielded equivalent product). The worst-case distribution parent in each subgroup is the product that reduces the house-side or street-side lumens the least.

¹¹ *Shielding angle* is defined in [ANSI/IES LS-1-22](#) as “the angle between a horizontal line through the light center and the line of sight at which the bare source first becomes visible.”

Table 37: Example of Shielded Products and Identified Worst-Case Efficacy and Distribution Parents

Family Name	Optic	Luminaire Efficacy w/o Shielding (lm/W)	House-Side (or Street-Side) Lumens w/o Shield	Shield Type	Shielding Angle	Shield Type Subgroup	Luminaire efficacy With Shield (lm/W)	House-Side (or Street-Side) Lumens With Shield	House-Side (or Street-Side) Reduction	Test Required
AXBXC	Type II	125	3,000	HSS	30	A	85	1,400	53%	LM-79/Color
AXBXC	Type II	125	3,000	HSS	45	A	88	1,200	60%	
AXBXC	Type III	125	3,500	HSS	30	A	87	1,700	51%	LM-79/Distribution
AXBXC	Type III	125	3,500	HSS	45	A	89	1,500	57%	
AXBXC	Type II	125	10,000	FSS	30	B	88	6,500	32%	LM-79/Color
AXBXC	Type II	125	10,000	FSS	45	B	90	5,000	47%	
AXBXC	Type III	125	9,500	FSS	30	B	89	7,000	30%	LM-79/Distribution
AXBXC	Type III	125	9,500	FSS	45	B	91	6,000	40%	

Table note: The hypothetical worst-case-efficacy parent for each shield type subgroup is shown in yellow. LM-79 color testing is required for the least efficacious shielded luminaire in shield type subgroup A (HSS), and the least efficacious shielded luminaire in shield type subgroup B (FSS) – rows 1 and 5. The hypothetical worst-case-distribution parent in each shield type subgroup is shown in blue.

In all cases, the testing to achieve an efficacy allowance for shielding is in addition to other testing specified in these technical requirements unless specific provisions are made. Shielded products must meet all other SSL V6.0 and LUNA V2.0 requirements and are offered efficacy allowances as long as zonal lumens are reduced by the amount specified in [Table 26: Efficacy Allowances Specific to LUNA Products](#). For example, if a family includes model numbers with house-side shielding accessories or options, of which only some meet the efficacy requirement with an allowance, testing would be required for 1) the worst-case-efficacy house-side shielded product that meets the allowance requirement, and 2) for the product with the lowest house-side lumen reduction as a function of the shield. Shielded products that have efficacies better than the worst-case shielded products, or the lowest house-side lumen reduction, can be child products. Submitters must supply the reported performance for their shielded and unshielded products. The allowance would apply to the specific subgroup of products using the given shield (e.g., HSS, CSS). Shield types may not be combined to create a larger subgroup. For example, cul-de-sac shields and house-side shields may not be combined to create one subgroup.

To determine if the shielding efficacy allowance may be granted, applicants must submit an IES file of the equivalent unshielded product with the same optical distribution and nominal light output as the submitted shielded worst-case-efficacy parent. To confirm the shielding allowance, the IES file associated with the unshielded product does not need to use absolute photometry (scaled photometry is acceptable).

24.2.10 Minimum Testing Requirements: Power Quality

Qualifying products must meet the requirements for power quality in their worst-case loading conditions.

In all cases, testing must be provided at the worst-case performance among a product's different operating modes. Due to design complexities of SSL luminaires and the many variables that could affect each performance metric with a minimum requirement, it is difficult to prescribe what the worst case will be for all situations. It is the manufacturer's responsibility to identify the worst-case operating mode of the product for each performance metric requirement and provide the appropriate test data. The DLC always reserves the right to ask for details of how the worst case was determined, including supporting engineering analysis and test data supporting the selection, as deemed necessary.

The DLC's understanding of the technology has led to an expectation that certain operating modes and design choices will be the worst cases. Power factor and THD are commonly seen to be worst-case at 277 V, while efficacy is commonly worst-case at 120 V. This is not necessarily true for all luminaire designs, so a manufacturer may submit independent test data for a different operating mode if it is accompanied by a technical rationale and supporting data (independent or in-house) demonstrating that what was tested is in fact the worst case. If testing is not conducted according to the expectations described above, DLC reviewers will ask for the testing at the expected worst-case operating modes, or a technical rationale with supporting data for an alternate worst-case operating mode for power factor, THD, and efficacy.

Alternatively, if the voltage inputs for a product include options for 347 V and/or 480 V, manufacturers will be expected to provide a rationale for how the worst case was determined, or test data at all voltages if a rationale cannot be provided for a particular operating mode.

When submitting applications for products using universal drivers, it is important to test at the appropriate operating mode for both efficacy and electrical measurements. (Please note that the DLC requires the current THD ("THDi" or "ATHD") performance, not voltage THD.)

The manufacturer may test only the light engine-electrical component system when conducting power factor and THD tests (for products with light engines that are separable from the housing).

24.2.11 Minimum Testing Requirements: FALD

FALD products are only eligible to be submitted as Level 2 DLC applications, and submittals must conform to the following testing rules in addition to the requirements of the family grouping policy, with the exception of "aimable" products. Specifically, for "aimable" products such as Flood and Spot Luminaires and Track or Monopoint Luminaires, where aimable capabilities are the norm, and where ZLD evaluation is relative to the center beam rather than to the environment, the Level 1 Application may continue to be used rather than the Level 2 Application, if desired.

Testing must be provided sufficient to justify bracketing all products in the group per the DLC [family grouping requirements](#).

Required testing is summarized in FALD Eligibility, with the full requirements for each type of FALD product described in detail below the table. For the purposes of this policy, the "worst-case" light



distribution setting means the combination of the Integral FALD setting and the component combination for Standard Component FALD that together result in the worst or most extreme value for the specified requirement.

Table 38: FALD Testing and Reporting Requirements

Technical Requirement	FALD Testing Required
LM-79 Report Required:	<ul style="list-style-type: none"> • Worst-case efficacy • Maximum power consumption • Worst-case light output • Representative highest CCT • Representative lowest CCT • Representative lowest CRI
Bench Test Required:	<ul style="list-style-type: none"> • Worst-case power quality (THD and PF)
In-Situ Temperature Measurement Test (ISTMT) Required:	<ul style="list-style-type: none"> • Worst-case thermal condition • For Premium classification, worst-case driver thermal condition
Photometric Distribution data required:	<ul style="list-style-type: none"> • All optical variations, excluding variations due to Integral FALD adjustability • One FALD setting designated for meeting ZLD requirements and listing on QPL

For all FALD products, testing shall be conducted in the light distribution settings that result in the worst-case performance for each of the following: efficacy, wattage, lumen output, power quality, and thermal in-situ temperature measurement testing (ISTMT). The combination of product and FALD setting tested must result in the worst-case performance within the family for each tested value and may require testing at multiple FALD settings: up to three LM-79 tests, one power quality bench test, and two ISTMT tests.

- LM-79 testing is required for the product and FALD setting combinations that represent the following worst cases:
 - The worst-case efficacy product and setting within the group
 - The maximum wattage product and setting within the group
 - The worst-case lumen output product and setting within the group
 - The worst-case power quality (THD, PF) product(s) and setting(s) within the group (may bench-tested)
 - Representative highest CCT
 - Representative lowest CCT
 - Representative lowest CRI



- In-situ temperature measurement testing (ISTMT) is required for the product and FALD setting combination that results in the worst-case thermal condition.
- If applying for Premium, ISTMT is required for the product and FALD setting combination that result in the worst-case driver thermal condition.

The manufacturer shall provide photometric distribution data that meets the Zonal Lumen Distribution Requirements of the PUD for which it is being submitted in IES file format.

The application for every family member must include at least one photometric distribution that meets the PUD's ZLD (and Spacing Criteria if applicable) requirements. Manufacturers will be required to identify the submitted IES file that represents, for each family member, a relative photometric distribution that the family member can achieve. Each identified IES file must meet the PUD's ZLD requirements.

Additionally, the following information must be provided with the DLC application materials:

- If the product capable of field adjustable light distribution, the applicant shall indicate in the application form, one of the following: "Integral FALD," "Standard Component FALD," "Integral and Standard Component FALD," or "No."
- The manufacturer shall complete a new field in the application form describing the Adjustable Distribution Setting designated to meet the zonal lumen distribution requirement for the PUD. This description will be displayed on the QPL in a new text field.
- The manufacturer shall describe in a separate document the adjustable setting position and/or the Standard Component combination that was used for each worst-case test submitted, and shall provide a written statement to justify why this setting and/or combination creates the extreme- or worst-case value in this test for each of the eight requirements described in the bulleted list above (nine for Premium classification). The description and justification shall be provided for each test in this separate document, uploaded within the application portal. A separate document with justification is required even when the Integral distribution setting or Standard Component combination is also included in the test report.

24.2.12 Minimum Testing Requirements: CCT-Tunable, Full Color-Tunable, and FACT Products

The testing for CCT-Tunable, Full Color-Tunable, and FACT products must be provided to cover all areas of investigation as with non-color-tuning family groups, plus additional testing across the color-tunable range for the least efficacious product.

Based on consideration of the entire color input signal range for all members of the product family, the product family member with the lowest efficacy of any product-and-color-control-setting combination in the group shall provide full LM-79/Color reports for all metrics other than distribution at the following test points:



- The **minimum CCT input control** setting
- The **maximum CCT input control** setting
- One **intermediate point**:
 - For products with continuously variable input signals and those with input signals offering an odd number of discrete settings, **the midpoint between the minimum and maximum CCT input signals, or the middle setting**
 - For input signals with an even number of discrete settings, **the lower of the two middle CCT input settings**
- Where none of the above tests result in the lowest efficacy condition, the **least efficacious** setting shall be LM-79/Color tested.
- If none of these test points represent the product in the family with 1) the minimum lumen output product-color-control-setting combination, 2) the minimum nominal CCT output, 3) the maximum nominal CCT output, 4) the minimum CRI, 5) the highest power consumption, or 6) the worst power quality, then additional LM-79 testing shall be performed for whichever product-and-color-control setting combination within the group performs at the worst-case family-wide for:
 - Full LM-79/Distribution report(s) (goniophotometric testing) for a **representative product for each optical variation** within the group
 - A test of the product **at the color control setting that produces the lowest lumen output** within the group
 - Where the minimum CCT is at least 100 K less than the CCT produced at the minimum CCT input control setting, a test of a product at the **minimum CCT**
 - Where the maximum CCT is at least 200 K greater than the CCT produced at the maximum CCT input control setting, a test of a product at the **maximum CCT**
 - A test of a product at the **minimum CRI**
 - A test of the product at the **highest power consumption setting**
- Where none of the above tests result in the worst-case Power Quality, applicant shall submit bench data documenting the product with the **worst power quality** (power factor and THDi)

Manufacturers must report the power consumption for each ANSI/NEMA C78.377-2024 CCT quadrangle from the minimum CCT to the maximum CCT, and for one reported CCT that falls between these upper and lower limits. If discrete input control settings do not allow the product to provide light within the CCT range of a particular bin, manufacturers must provide the CCT and power consumption of the closest CCT to that range. If input control settings allow for more than one setting within an ANSI quadrangle, only the data for the setting that produces the actual CCT closest to the nominal CCT center point for the bin per the ANSI standard shall be provided. The data should be provided in the format of [Table 39](#). The DLC will accept the following sources for self-reported or self-rated performance data:



- **In-house laboratory test:** In-house test reports from tests conducted in accordance with ANSI/IES LM-79.
- **Calculated scaling:** Mathematical characterization of luminaire performance based on manufacturer-developed scaling methodology. The manufacturer must provide a description of the scaling methodology employed and the technical basis for its validity. The DLC reserves the right to accept or reject the methodology for use in qualifying products.

Table 39: Data Reporting Format for FACT, CCT-Tunable, and Full Color-Tunable Product Submissions

ANSI CCT Quadrangle or Worst-Case Value	Measured CCT (K)	Power Consumption (W)	Lumen Output (lm)	Input Control Signal Applied
1800 K				
2000 K				
2200 K				
2500 K				
2700 K				
3000 K				
3500 K				
4000 K				
4500 K				
5000 K				
5700 K				
6500 K				
Lowest Efficacy				
Maximum Power				

* Table note: Omit any CCTs outside the product range.

24.2.12.1 Guidance for "Input Control Signal Applied" Field in Table 39

Applicants should use the following guidance when completing the "Input Control Signal Applied" field for Color-Tunable products:

- The values shown should be specific to how the luminaire responds to the control signal, not varying for a single luminaire depending on the control hardware or software used.
- 0 – 10 V control systems should provide an actual DC voltage value, shown to the tenth of a volt.
- DALI color control using DALI 209 should provide a value from 0 to 254. Other DALI color control schemes not based around values from 0 to 254 should follow the guidelines for proprietary signals (see next bullet).
- All other control protocols for color tuning, including those that use proprietary control signals, should provide a percentage value from 0% to 100%. That percentage should represent the

control signal applied from lowest CCT to highest CCT, rounded to the nearest percentage. It is important to note that this should not be the percentage of CCT range from lowest CCT to highest CCT; rather, it should reflect the *control signal* applied. DLC is not looking for values that simply show that 3500 K is numerically 25% of the way from 3000 K to 5000 K but wants to document how manufacturers have chosen to translate the CCT range.

- The values shown should encompass the full CCT range of the product. If the maximum CCT or minimum CCT point varies for a given product depending on the control signal used, values provided in the table should include the highest maximum CCT and the lowest minimum CCT, even if different control signals are required to achieve the two.

24.2.13 Minimum Testing Requirements: Warm-Dimming Products

Warm-Dimming product submittals must include a single full LM-79/Color report performed at the **maximum setting of the dimming input control**.

Unless otherwise noted, all DLC Standard, Premium, and LUNA program requirements remain applicable in addition to the thresholds and testing requirements specified in this section.

Additionally, Warm-Dimming product submittals must include a full LM-79/Color report performed at the **maximum setting of the dimming input control**.

Manufacturers may provide in-house testing on driver characteristics and zonal lumen output, or other testing that might be necessary to support the designation of a least-inefficient or highest power-consumption control setting.

24.2.14 Minimum Testing Requirements: Modular Products

The DLC requires specific testing and reporting to qualify modular products with external power supplies. The DLC lists modular products with external power supplies by unit, with unit-level performance data for light output characteristics. To obtain data that is accurate to all relevant metrics for an individual module and appropriately construct the system, the DLC requires testing conducted as follows:

- Each individually unique module should be tested alone using the goniophotometer method according to LM-79 for light output and light distribution measurements. From this testing, the DLC will obtain the light output and light distribution (zonal lumen density) information.
- Additionally, the worst-case system configuration should be tested (using either the integrating sphere-spectroradiometer method or goniometer-spectroradiometer method in accordance with LM-79) for the other necessary metrics, such as efficacy, color, and power quality. This may involve multiple photometric measurements to appropriately measure the total light output of the system for efficacy calculations, along with the electrical measurements for the system as a whole. The DLC will use the measurements made on this system to evaluate compliance with DLC requirements and determine listed test performance information for these metrics.



- The worst-case system will be the configuration in the submitted product line that would result in the lowest efficacy (typically at the worst (smallest) loading conditions for a given power supply or driver) that would meet the DLC requirements.



25 Testing Requirements for Long and Complex Products

25.1 Introduction

The DLC understands that in some scenarios, products that are required to be tested may not physically fit within the testing apparatus. This is often seen with eight-foot linear-type luminaires that do not fit in standard goniophotometers, though other restrictions may exist. This section describes alternative testing pathways for these products.

Requirements in this section are unchanged from SSL V5.1.

25.2 Alternative Testing Pathway

In the event that a product is identified as requiring testing for a DLC application but cannot be tested due to the constraints of the testing equipment, the DLC will need to understand and collect the following information:

- Specific reasons why the product in question cannot be tested
- A proposal from the manufacturer on how to evaluate the performance of the product; proposals must be technically sound and demonstrate a thorough understanding of the product's construction and performance-affecting variables.
- Rationale for why the method described in the proposal will provide appropriate representation of the product's performance

Proposals, once complete with the details mentioned above, will be reviewed on a case-by-case basis by DLC program management. This information must be provided ahead of the application itself, as proposals need to be approved prior to allowing the use of alternate data within an application. This will help ensure that application reviews are completed as efficiently as possible. The DLC reserves the right to request additional information, and manufacturers should be prepared to provide documentation that addresses any concerns that might arise.

25.3 Alternative Testing for Linear Style Products

25.3.1 Testing Linear Style Products With a Length Greater Than or Equal to Five Feet

Linear style products with a length greater than or equal to five feet (i.e., the “original configuration”) must be submitted as a Level 2 application and may deviate from the requirement that “the multiplier field in the IES files shall be 1.0 and may not be scaled.” Were there no testing constraints, the original configuration would be tested to demonstrate compliance with the distribution requirements.

Equivalent shorter products are defined as products whose cross-sectional distribution is equivalent to that of the original, five-foot or longer, configuration.

The original configuration may be qualified using the following procedures:

- A full LM-79/Color report must be provided for the original configuration and must be conducted strictly according to LM-79, with no scaling. This is anticipated to be an integrating sphere test.
- A full LM-79/Color report and a full LM-79/Distribution report must also be provided for an equivalent shorter product.
- The original configuration products must be submitted in a family with equivalent shorter products that are tested in a goniophotometer.
- A full LM-79/Distribution report must be provided for the original configuration, and must contain:
 - Electrical characteristics from the full LM-79/Color report of the original configuration
 - Luminous intensity distribution (candela array) derived from the goniophotometer testing of the equivalent shorter product and a multiplier whose value is greater than one and is calculated as the ratio of the lumen output from the full LM-79/Color report of the original configuration divided by the lumen output from the full LM-79/Color report of the equivalent shorter product; the luminous area in the IES file must be representative of the original configuration
- If this alternative method is used, data from the scaled IES files will not be shown on the QPL as tested data. The equivalent shorter product will be listed instead on the QPL as a parent product with its tested data shown.

25.4 Alternative Testing for Luminaires With Direct and Indirect Components

The DLC requires that all unique optical variations be tested and a full LM-79/Distribution report be provided during the submission process. The DLC understands that there can be increased distribution-testing burden for certain linear ambient luminaires with indirect components and with large numbers of optical variations, due to the multiplicative effects of distribution options and lumen output options of direct and indirect components. For luminaires with both direct and indirect optical distributions, lumen output can differ for the direct and indirect components individually, which can result in a different overall luminaire light distribution. Since lumen output can be easily and accurately scaled, these types of distribution changes can also be systematically scaled accurately.

For luminaires with both direct and indirect optical distributions, the DLC allows compliance with the technical requirements to be demonstrated by estimating certain distribution changes.



These product components may, but are not required to, deviate from the requirement that “the multiplier field in IES files shall be 1.0 and may not be scaled” by following the requirements and procedure described here:

- A completed **Linear Ambient With Indirect Component Distribution Performance Summary Excel file** must be provided, containing all models to be qualified. The file is available on the SSL V6 product qualification pages.
 - Worst-case analysis conducted using the procedure described herein must take into account the effects of color properties.
- A detailed description of the scaling methodology used to generate the estimated zonal lumen distribution must be included in the distribution performance summary Excel file.
 - The recommended method for scaling light output is as follows:
 - For each downlight light output option and each uplight light output option, LM-79 color tests must be conducted at a manufacturer-selected optic, CCT, and CRI configuration.
 - Power demand at each light output must also be measured (in general, this does not change significantly based on color characteristics or optics).
 - Based on this testing, a scaling factor is generated for estimation of lumen output based on the change of lumen package.
 - LM-79 color tests must be conducted for each optical variation at a manufacturer-selected light output, CCT, and CRI combination.
 - Based on this testing, a scaling factor is generated for estimation of lumen output based on optical changes.
 - Similarly, LED manufacturers may provide scaling factors to apply for estimation of lumen output scaling based on CRI or CCT changes.
 - In addition, goniometer testing must be conducted on each unique direct and each unique indirect optical variation. This testing is not only recommended to scale performance data but is also required in applications submitted using this method.
 - A full LM-79/Distribution report must be provided for each unique direct distribution pattern at any lumen output in isolation (that is, with the indirect component de-energized).
 - A full LM-79/Distribution report must be provided for all unique indirect distribution patterns at any lumen output in isolation (that is, with the direct component de-energized).



multiplying the candela values of the four-foot goniophotometer output by a scaling factor. That factor shall be derived by dividing the tested lumen output of the eight-foot lamp by the tested lumen output of the four-foot lamp, as obtained from the integrating sphere.

The results must meet the beam angle requirements. Applicants must provide results from the eight-foot testing in the integrating sphere, the four-foot testing in the integrating sphere, and the four-foot testing in the goniophotometer, as well as the scaled eight-foot IES file. The applicant must also provide the workflow used, to demonstrate the calculation of the scaling factor and to identify, within the photometric report, the candela values derived via calculation. In addition, a photo of the eight-foot and four-foot LED layouts side-by-side, as well as a cross-section diagram of construction for both products, must be submitted.



26 Testing and Reporting Requirements for Alternate LEDs and Drivers

26.1 Introduction

The DLC has received feedback about supply chain challenges from qualifying manufacturers who have requested that the DLC develop an alternate (dual or multiple) sourcing policy to support listing a single product on the QPL that may be manufactured with alternate, equivalent components, such as drivers or LEDs, as needed. SSL V6.0 adds a new reporting option for alternate, equivalent LEDs and drivers, to demonstrate that these alternate subcomponents meet lifetime requirements, along with manufacturer attestation that LM-79 tests are conducted with worst-case alternate LED and driver options.

26.2 Testing and Reporting Requirements for Alternate LEDs and Drivers

To ensure that DLC listed products maintain their performance when using alternate LED and/or drivers, these alternately sourced equivalent drivers and LEDs are only eligible when these components do not significantly change the performance of the qualifying product. That is, the tested and reported data for the qualifying products must be equivalent regardless of which component is being used. SSL V6.0 provides a methodology for manufacturers to report equivalent, alternately sourced components that are being used, as described below.

Manufacturers must attest that alternate components, such as alternate drivers and LEDs, do not change the performance characteristics of the qualifying products beyond the acceptable tolerances specific to an original subcomponent, as defined in [Table 19](#). If a manufacturer reports that alternate sourcing is occurring, then specification sheets for all alternate components must be provided.

All alternate LEDs and alternate drivers must demonstrate that subcomponent-level lumen maintenance and driver lifetime requirements are met as described in this Technical Requirements document. For alternative drivers, LM-79 testing must be conducted on the worst-case variation and power quality testing (i.e., PF and THD) must be conducted on each unique driver. If Premium, alternative drivers must provide testing to demonstrate compliance with the driver lifetime requirements.

LM-79 testing and power quality testing (i.e., PF and THD) must be conducted on the worst-case variation, considering all alternate components.

The DLC reserves the right to request additional information as appropriate.



27 Additional Requirements for LM-79, LM-80, and TM-21 Test Reports

27.1 Introduction

This section specifies additional reporting requirements for all submitted LM-79, LM-80, and TM-21 test reports for all products regardless of Program, Classification, Category, General Application, or Primary Use Designation. Test reports that do not comply will not be accepted.

SSL V6.0 and LUNA V2.0 include the latest industry standards, such as the ANSI/IES LM-79-24 standard, in addition to the requirements introduced as part of SSL V5.1. To move away from deprecated test standards, SSL V6.0 and LUNA V2.0 no longer accept test reports for products tested to IES LM-79-08 for new listings.

Additionally, to support the adoption of the latest industry reporting standards, SSL V6.0 and LUNA V2.0 include additional reporting pathways for the digital format of LM-80 report results in accordance with ANSI/IES TM-41-24, along with a PDF of the LM-80 report. This includes maintaining the compliance requirements related to TM-21 and its Annex B to address concerns around projected lumen maintenance claims and current DLC provisions.

27.2 ANSI/IES LM-79 (-19 and -24 Versions)

SSL Level 1 products and Level 2 products shall be tested according to the guidelines in specified ANSI/IES Lighting Measurement (LM) documents. Test reports generated by a test lab that complies with the [DLC Testing Lab Requirements for LM-79 Testing](#) will be accepted only if all optical and electrical performance characteristics are tested and documented as described below. Testing according to ANSI/IES LM-79-19 and -24 versions will be accepted. All tests shall be conducted at the full output or non-dimmed state.

All submitted photometric test reports must comply with the full LM-79/Color report or full LM-79/Distribution report definitions provided below. Configurations tested to produce full LM-79/Color reports and full LM-79/Distribution reports will be listed as parent products on the QPL, with the tested performance data based on the QPL listing information in each applicable section. If a full LM-79/Color report and full LM-79/Distribution report are provided on the same configuration, the tested performance listed on the QPL will be the lowest-efficacy data set.

Test reports that require color performance information (generally expected to be from testing in an integrating sphere, though gonio-spectroradiometer testing is also acceptable) do not require distribution performance information. These color-specific test reports are generally referred to within this SSL V6.0 policy as **“full LM-79/Color reports”** and shall be in PDF format and include, but are not limited to:

- Electrical characteristics: wattage, input voltage, THD, and PF



- Total luminous flux
- Efficacy
- Chromaticity: (x,y) and (u',v')
- CCT and Duv
- [ANSI/IES TM-30-18](#) or [ANSI/IES TM-30-24](#) Full Color Report (per TM-30's Annex D, Figure D-3)
- [CIE 13.3-1995](#) complete Color Rendering Index Detail
- Accompanying ANSI/IES TM-27 SPD files document ([IES TM-27-14](#) or [ANSI/IES TM-27-20](#)) with spectral power distribution data from 380 through 780 nm in increments ≤ 5 nm
 - The product model number shall be present and shall match in the TM-27 and LM-79 documents.
- Optionally reported for LUNA V2.0 only: A TM-33 (ANSI/IES TM-33-18 or -23) XML document meeting the following requirements:
 - The test report number, test lab, report date, manufacturer, luminaire catalog number, and description are correctly and pertinently indicated using the header elements <ReportNumber>, <Laboratory>, <ReportDate>, <Manufacturer>, <CatalogNumber> and <Description>, respectively.
 - The Luminaire Dimension Elements (Section 4.3.1 in TM-33), indicating the housing dimensions, and the Number of Emitters are required. DLC reviewers will verify the luminaire dimensions in the TM-33 XML document against the luminaire physical dimensions that are provided in the specification sheet, LM-79 test report, or as separate application submission materials.
 - Emitter Elements (Section 4.5 in TM-33) must include all required elements from [Table 4](#) in ANSI/IES TM-33-18 or -23.
 - Emitter spectral data with absolute luminaire-level spectral power distribution data from 380 through 780 nm must be included in increments ≤ 5 nm.
 - For the spectral subgrouping parent with the highest CCT and highest lumen output, the TM-33 XML document must either 1) include both the emitter spectral data and the emitter luminous intensity data for a single tested product, or 2) provide emitter spectral and emitter luminous intensity data for a single tested product in separate TM-33 XML documents.
 - For the products with the lowest CCT and highest lumen output, the TM-33 XML document may include only the emitter spectral data without the emitter luminous data for a single tested product.
 - The DLC recommends inclusion of additional, optional TM-30 elements that describe color quality attributes, such as color correlated temperature and color rendering, but they are not required at this time.



- Required TM-27 files and optional TM-33 documents must report spectral data in wavelength increments ≤ 5 nm.
- The product catalog number must be present and matched in all relevant TM-27, TM-33, LM-63, and LM-79 documents.

All information listed above, except the accompanying ANSI/IES TM-27 SPD files or ANSI/IES TM-33 XML documents, shall be included in a single LM-79 test report. Separate ANSI/IES TM-30-18 or -24 reports will not be accepted.

Test reports that require distribution performance information (generally expected to be from testing with a goniophotometer) do not require color performance information. These distribution-specific test reports are generally referred to within this SSL V6.0 policy as **“full LM-79/Distribution reports”** and shall be in PDF format and include, but are not limited to:

- Electrical characteristics: wattage and input voltage
- Luminous intensity distribution: candela array
- Accompanying IES file (IES LM-63/R2008 or ANSI/IES LM-63-19) meeting the following requirements:
 - The test report number, test lab, issue date, manufacturer, and luminaire catalog number are correctly and pertinently indicated using the keywords [TEST], [TESTLAB], [ISSUEDATE], [MANUFAC], and [LUMCAT], respectively.
 - Scaled IES files are not allowed. The multiplier field in IES LM-63-02/R2008 files shall only be 1.0, i.e., the candela values shall be from an actual goniophotometer test, and scaled values are not permitted.
 - For manufacturers submitting an ANSI/IES LM-63-19 IES file, products must be tested and reported using absolute photometry methods per ANSI/IES LM-63-19, not scaled photometry, and must include a [FILEGENINFO] keyword with information about the File Generation Type and the File Generation Type Value 1.10000 or 1.11000, per ANSI/IES LM-63-19 Table 2.
 - The luminous intensity data shall be presented using Type C photometry format, except for products in the Primary Use Designations of Flood and Spot Luminaires, which may use the Type B photometry format.
 - The luminous dimensions shall appropriately reflect the luminous opening of the luminaire. (See next section, “Additional Guidance on Luminous Dimensions,” for additional detailed guidelines.) In no circumstance shall the luminous dimensions be zero or exceed the luminaire’s physical dimensions, and DLC reviewers will verify the luminous dimensions in the IES file against the luminaire physical dimensions that are provided in the specification sheet, LM-79 test report, or as separate application submission materials.
 - The angular resolution for the luminous intensity distribution data shall comply with the scanning resolution specified in LM-79 (Section 7.3.3 in ANSI/IES LM-79-19 and ANSI/IES



LM-79-24) and be fine enough to accurately characterize the product's intensity distribution. For products with a wide-angle, smooth intensity distribution, the luminous intensity distribution data shall be in a resolution of 5 degrees or less in the vertical plane and 22.5 degrees or less in horizontal planes. A smaller vertical angular increment must be used for products whose luminous intensity changes rapidly as a function of angle.

- Optionally reported for LUNA V2.0 only: A TM-33 (ANSI/IES TM-33-18) XML document meeting the following minimum requirements:
 - Alongside other TM-33 required elements, the test report number, test lab, report date, manufacturer, luminaire catalog number, and description are correctly and pertinently indicated using the header elements <ReportNumber>, <Laboratory>, <ReportDate>, <Manufacturer>, <CatalogNumber>, and <Description>, respectively.
 - The Luminaire Dimension Elements (Section 4.3.1 in TM-33), indicating the housing dimensions, and the Number of Emitters are required. DLC reviewers will verify that the luminaire dimensions in the TM-33 XML document against the luminaire physical dimensions that are provided in the specification sheet, LM-79 test report, or as separate application submission materials.
 - Emitter elements (Section 4.5 in TM-33) must include all required elements from Table 10 in TM-33-18.
 - The Intensity Scaling Element (Section 4.5.13.2.4.1 in TM-33) must be “false,” meaning that the reported intensity data has not been scaled uniformly with respect to laboratory measurements.
 - The luminous intensity distribution must be presented as emitter luminous intensity data.
 - If a given parent product or single product with a unique optic and the highest lumen output has been tested to meet both the spectral and distribution requirements, a TM33 XML document must be submitted with both spectral and luminous intensity data or provide emitter spectral and emitter luminous intensity data for a single tested product in separate TM-33 XML documents. The emission area elements (Section 4.5.23 in TM-33) must appropriately reflect the luminous opening of the luminaire. In no circumstance should the emission areas be zero or exceed the luminaire's housing dimensions.
 - The angular resolution for the emitter luminous intensity data in the TM-33 XML document must comply with the scanning resolution specified in LM-79 (Section 7.3.3 in ANSI/IES LM-79-19 and ANSI/IES LM-79-24) and be fine enough to accurately characterize the product's intensity distribution. For products with a wide-angle, smooth intensity distribution, the luminous intensity distribution data must be in a resolution of 5 degrees or less in the vertical plane and 22.5 degrees or less in horizontal

planes. A smaller vertical angular increment must be used for products whose luminous intensity changes rapidly as a function of angle.

- The DLC allows submitters to use the symmetry rules for horizontal angles from ANSI/IES LM-63 to represent their luminous intensity distribution data in the XML document.

Test reports containing only a partial set of LM-79 metrics (for example, an integrating sphere test report without luminous flux reported), will not be accepted for application review purposes. For clarity, even if a test is needed for purposes of verifying chromaticity, it must be a full LM-79/Color report as described herein, with all required metrics reported.

- Indoor luminaires with uplight and downlight distributions may be tested such that the uplight and downlight components are measured separately in the goniophotometer, if the goniophotometer mounting structure occludes the uplight or downlight distribution during testing. In the case of separate measurements:
 - The distributions shall then be combined to produce the full LM-79/Distribution report, including the IES file. The data from this IES file will not be displayed on the QPL.
 - In addition, an [OTHER] keyword shall be added to the IES file header as follows:
 - [OTHER] This photometric file contains combined distribution data from separate measurements.

The DLC reserves the right to request additional information about the separate measurements, and manufacturers should be prepared to provide documentation to address any concerns that might occur.

27.2.1 Additional Guidance on Luminous Dimensions for UGR Calculations

Per ANSI/IES LM-63-19: “[The luminous dimensions] refer to the luminous (that is, light emitting) opening of the luminaire, not its physical dimensions. They are meant to approximate the luminous opening (either as a luminous area or luminous volume) for lighting calculations. ... It is assumed that there is only one luminous opening in each IES LM-63-2019 data file.”

Modern SSL luminaires may have more than one luminous opening, and regardless of the number of luminous openings, the width, length, and height fields in the IES file must use one of the luminous shapes available in IES LM-63 to describe the smallest geometry that completely encompasses all of the light emitting surfaces of the product.

For example, for a troffer with a luminous basket, the length, width, and height of the entire luminaire must be represented as a rectangular object with luminous sides or as a rectangle, per Annex D in ANSI/IES LM-63-19. [Figure 3](#) and [Figure 4](#) show examples of these two luminous shapes.

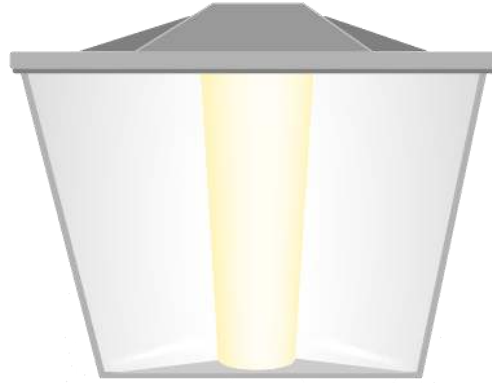

Figure 3: Isometric view of a troffer with luminous basket and non-luminous panels on each side. The luminous shape would have the width and length of the rectangle . Its height would be 0.



Figure 4: Isometric view of a troffer with a luminous basket and luminous panels on each side. The luminous shape would be represented by a rectangular object with luminous sides encompassing the entire luminaire.

27.2.2 Additional Reporting Guidelines: Photometric Software in Application Review

During the application review process, DLC reviewers will use Photometric Toolbox (Lighting Analysts, Inc, version 2.14 or newer) to calculate ZLD, SC, BUG ratings (for Outdoor Luminaires and retrofit kits only, lamps do not need to report BUG ratings), beam angle, and UGR threshold values (for Premium for Troffer PUDs and Efficacy Allowance pursuant for enhanced discomfort glare control per Table 18) from the provided IES files.

27.3 IES TM-21-11, ANSI/IES TM-21-19, ANSI/IES TM-21-21, and the ANSI/IES TM-21 Calculator

Long-term lumen maintenance for SSL Level 1 or Level 2 products shall be projected according to the guidelines in specified in [ANSI/IES TM-21](#), or the current version of that standard. Long-term lumen



maintenance projections will be accepted only if fully compliant with the standard utilized. This includes, but is not limited to, the following:

- Luminous flux data collection and selection (Sections 4.3 and 4.4)
- Data used for the curve-fit (Section 5.2.3)
- Temperature data interpolation (Section 6.0)
- Limit for Extrapolation (Section 6.5) or Limit for Projecting Flex Maintenance (Section 5.2.7).

The DLC is making an exception to allow uneven interval reporting for TM-21 projections drawing from an LM-80 report initiated prior to March 31, 2015, one year after the introduction of even intervals in Addendum A to TM-21. Otherwise, TM-21 projections not fully compliant with [ANSI/IES TM-21](#), OR the current version of that standard, will not be accepted. A complete and accurate copy of [the December 31, 2023, version of the ENERGY STAR TM-21 calculator](#) OR a complete and accurate copy of [the ANSI/IES TM-21 Calculator report](#), in both PDF and JSON format, is required for submission, and will suffice in meeting the above requirements, unless uneven interval reporting is used for TM-21 projections. In cases where uneven intervals are used, [the February 08, 2016, version of the ENERGY STAR TM-21 calculator](#) shall be used. In no case will the DLC allow uneven intervals of less than 250 hours.

Additionally, under SSL V6.0, the DLC will require LM-80 data sets to be sufficient for projecting to the required lumen-maintenance hours via TM-21 rules alone, to demonstrate compliance with the L_{70} lumen maintenance requirement. Products with LM-80 data sets insufficient to do so will be ineligible for qualification.

To clarify, projections shall not extend beyond 6 times the test duration for 20 or more samples (5.5 times for 10 to 19 samples).

- For example, LM-80 data sets used to project 50,000 hours are required to demonstrate a test duration of at least 8,333.33 hours for 20 or more samples.

Note: In response to ENERGY STAR retiring its TM-21 calculator, the DLC intends to transition away from all pathways requiring ENERGY STAR TM-21 calculators, to requiring use of the [ANSI/IES TM-21 calculator](#). ENERGY STAR pathways are still acceptable under SSL V6.0.

27.4 IES LM-80 Versions

The DLC expects LM-80 data to be submitted in the application to support long-term lumen maintenance projections for SSL Level 1 or Level 2 products. LM-80 data shall be reported according to the current version of this standard (ANSI/IES LM-80-21). Older versions of LM-80 (ANSI/IES LM-80-20, ANSI/IES LM-80-15, IES LM-80-08) are also acceptable and data shall be reported according to the guidelines in those older versions.



Part VII: Appendices

This section contains information helpful for understanding the requirements throughout the document but have been located here due to the length of the appendices.

28 Appendix A: Primary Use Designation Definitions

28.1 Outdoor

The additional reporting requirements for Solar Powered Outdoor Luminaire PUDs are not reflected in their definitions. As a result, these PUDs adopt the same definitions as the analogous **Outdoor** products.

28.1.1 Outdoor Pole/Arm-Mounted Area and Roadway Luminaires

Typical streetlight or parking lot light. Examples include cobra-head and shoe-box shapes. An example is shown in **Figure 5**.



Figure 5: Example of an outdoor pole/arm-mounted area and roadway luminaire. (Image credit: Focus on Energy®)

28.1.2 Outdoor Pole/Arm-Mounted Decorative Luminaires

Commonly, an in-town streetlight or historical reproduction; examples include acorn-shaped, post-top, lantern, and teardrop. These luminaires offer a stylish or decorative element that is clear in the luminaire design. An example is shown in **Figure 6**.



Figure 6: Example of an outdoor pole/arm-mounted decorative luminaire. (Image credit: Efficiency Vermont)

28.1.3 Outdoor Zero-Uplight Wall-Mounted Area Luminaires

Typically, a walkway or security light, affixed to building wall. May be box-shaped. These products produce no uplight. Examples of eligible and non-eligible types are shown in **Figure 7** and **Figure 8**.



Figure 7: Example of a non-eligible Outdoor zero-uplight wall-mounted luminaire. (Image credit: Focus on Energy®)



Figure 8: Example of an eligible outdoor zero-uplight wall-mounted luminaire. (Image credit: Focus on Energy®)

28.1.4 Outdoor Uplight-Emitting Wall-Mounted Area Luminaires

Typically, a walkway or security light, affixed to building wall. Commonly known as a “wall pack” and may be box-shaped. The products produce a non-negligible amount of uplight. Products in this group are meant to be fixed in place and provide general illumination, not directional light. Examples of eligible and non-eligible types are shown in **Figure 9**,

Figure 10, and **Figure 11**.

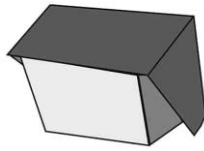

Figure 9: Example of an eligible outdoor uplight-emitting wall-mounted area luminaire. (Image credit: Focus on Energy®)

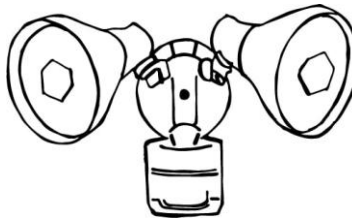

Figure 10: Example of a non-eligible outdoor uplight-emitting wall-mounted area luminaire. (Image credit: Focus on Energy®)



Figure 11: Example of a non-eligible outdoor uplight-emitting wall-mounted area luminaire. (Image credit: Focus on Energy®)

28.1.5 Turtle Lighting Zero-Uplight Pole/Arm-Mounted Area and Roadway Luminaires (Low Output Only)

A streetlight or parking lot light used in coastal areas where sea turtles are present. They are typically designed to include direct-emission (i.e., narrowband) Amber LEDs. The DLC requires that these luminaires have no directly emitted uplight and have limited light output at 60 degrees vertical and higher.



Figure 12: Example of a Turtle Lighting Zero-Uplight Pole/Arm-Mounted Area and Roadway Luminaire (Low Output Only)

28.1.6 Turtle Lighting Zero-Uplight Wall-Mounted Area Luminaires (Low Output Only)

A walkway or security light, affixed to a building wall. Commonly known as a “wall pack” and may be box-shaped. They are typically designed to include direct-emission (i.e., narrowband) Amber LEDs. The DLC requires that these luminaires have no directly emitted uplight and have limited light output at 60 degrees vertical and higher.



Figure 13: Example of a Turtle Lighting Zero-Uplight Wall-Mounted Area Luminaires (Low Output Only)

28.1.7 Turtle Lighting Zero-Uplight Bollards (Low Output Only)

An architectural outdoor ground-mounted luminaire that is short and upright, typically giving off light from the sides, and used to illuminate walkways, steps, or pathways. They are typically designed to include direct-emission (i.e., narrowband) Amber LEDs. The DLC requires that these luminaires have no directly emitted uplight and have limited light output at 60 degrees vertical and higher.



Figure 14: Example of a Turtle Lighting Zero-Uplight Bollard (Low Output Only)

28.1.8 Bollards

Architectural outdoor ground-mounted luminaire that is short, and upright, typically giving off light from the top or the sides, and used to illuminate walkways, steps, or pathways. An example is shown in **Figure 15**.



Figure 15: Example of a bollard. (Image credit: Efficiency Vermont)

28.1.9 Parking Garage Luminaires

A type of ceiling-mounted luminaire for use outdoors or in locations open to the elements in multi-deck garages. An example is shown in **Figure 16**.

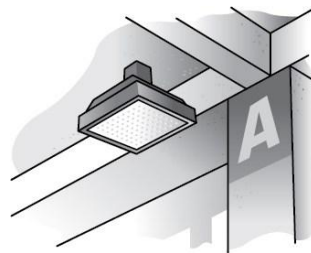

Figure 16: Example of a parking garage luminaire. (Image credit: Focus on Energy®)

28.1.10 Fuel Pump Canopy Luminaires

A type of ceiling-mounted luminaire for use outdoors or in locations open to the elements in gas station canopies. An example is shown in **Figure 17**.

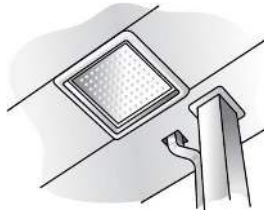

Figure 17: Example of a fuel pump canopy luminaire. (Image credit: Focus on Energy®)

28.1.11 Architectural Flood and Spot Luminaires

A type of directional luminaire intended to highlight architecture, objects, and areas in outdoor lighting that do not include roadway or tunnel lighting. May include billboard lighting. Manufacturers must follow NEMA guidelines for declaring beam spread. Examples are shown in **Figure 18** and **Figure 19**.



Figure 18: Example of an eligible architectural flood or spot luminaire. (Image credit: Focus on Energy®)



Figure 19: Example of an eligible architectural flood or spot luminaire.

28.1.12 Stairwell and Passageway Luminaires

A corner- or surface-mounted luminaire that provides lighting in stairwells and passageways. Luminaires must meet one of the following conditions: include integral controls; operate off of remote sensors, where remote sensor is packaged together with the luminaire under a single model number; or be designed to operate off of remote sensors, where the luminaire and sensors are sold separately, but the

luminaire has features enabling communication with a remote sensor. Controls must ensure that the luminaire reverts to lower-power, lower-light output state when there are no occupants in the vicinity. An example is shown in **Figure 20**.



Figure 20: Example of an eligible stairwell/passageway luminaire. (Image credit: Focus on Energy®)

28.1.13 Hazardous Environment Area Luminaires

A non-directional outdoor luminaire that provides illumination of general spaces, intended for use in hazardous locations as defined in [UL 844](#) (e.g., extreme temperatures, vibrations, volatile substances). Examples include lighting for parking areas, walkways, or building grounds. Mounting structures that include poles, arms, or canopy or ceiling mounts are eligible. Products that are aligned with PUDs C and D are not eligible under this definition.



Figure 21: Example of a Hazardous Environment Area Luminaire

28.1.14 Sports Lighting Luminaires

A directional outdoor area luminaire intended for lighting the active areas of sporting event spaces (e.g., stadiums, fields, courts).



Figure 22: An example of a sports lighting luminaire.

28.2 Indoor

28.2.1 Wall Wash Luminaires

A type of luminaire designed to illuminate walls in interior spaces.

28.2.2 Track or Mono-point Luminaires

Usually on ceiling-mounted tracks or a fixed single head. Adjustable-aim “cans.” Complete LED luminaires (not replacement lamps in existing cans, such as PAR 38 or MR16 lamps). Examples of eligible and non-eligible types are shown in **Figure 23** and **Figure 24**.



Figure 23: Example of an eligible track or mono-point directional luminaire. (Image credit: Focus on Energy®)



Figure 24: Examples of non-eligible track or mono-point directional luminaires. (Image credit: Focus on Energy®)

28.2.3 Display Case Luminaires

A strip light, usually mounted horizontally at frame edges of glass case. Replacement lamps such as MR16 or PAR 38 lamps are not eligible.

28.2.4 Horizontal Refrigerated Case Luminaires

A strip light in refrigerator cases, horizontally mounted along refrigerator case shelves or canopies. This Category covers only complete luminaires, with all necessary components. Replacement lamps are not currently eligible under this Category.

28.2.5 Vertical Refrigerated Case Luminaires

A strip light in refrigerator cases, vertically mounted along refrigerator case door mullions. This Category covers only complete luminaires, with all necessary components. Replacement lamps are not currently eligible under this Category. An example is shown in **Figure 25**.



Figure 25: Example of eligible display case luminaires. (Image Credit: Efficiency Vermont)

28.2.6 2x2 Luminaires for Ambient Lighting of Interior Commercial Spaces

A common recessed, suspended, or surface-mounted luminaire intended to provide ambient lighting in settings such as office spaces, schools, retail stores, and other commercial environments. Products submitted in these categories must meet the stated form factors with a tolerance of ± 4 inches.

28.2.7 1x4 Luminaires for Ambient Lighting of Interior Commercial Spaces

A common recessed, suspended, or surface-mounted luminaire intended to provide ambient lighting in settings such as office spaces, schools, retail stores, and other commercial environments. Products submitted in these categories must meet the stated form factors with a tolerance of ± 4 inches.

28.2.8 2x4 Luminaires for Ambient Lighting of Interior Commercial Spaces

A common recessed, suspended, or surface-mounted luminaire intended to provide ambient lighting in settings such as office spaces, schools, retail stores, and other commercial environments. Products submitted in these categories must meet the stated form factors with a tolerance of ± 4 inches.

28.2.9 Direct Linear Ambient Luminaires

A suspended, surface-mounted, pendant, or recessed luminaire, no wider than 12 inches, designed to provide direct lighting (i.e., where 50% or more of the light distribution is directed downward) in indoor spaces. Products may be designed to be installed end-to-end to create long chains, and may be described as direct, semi-direct, or general diffuse, depending on intended lighting distribution. Utilitarian “strip” style fixtures are *not* eligible under this Category. Products intended for cove lighting or marketed as “decorative” or “architectural” are eligible under this Category. An example is shown in **Figure 26**.



Figure 26: Example of an eligible direct linear ambient luminaire: (Image credit: Focus on Energy®)

28.2.10 Linear Ambient Luminaires With Indirect Component

A suspended, surface-mounted, pendant, or recessed luminaire, no wider than 12 inches, designed to provide ambient lighting (i.e., where more than 50% of the light distribution is directed upward) in indoor spaces, including an indirect distribution. Products may be designed to be installed end-to-end to create long chains, and may be described as indirect, semi-direct, semi-indirect, direct-indirect, indirect-direct, or general diffuse, depending on intended lighting distribution. Utilitarian “strip” style fixtures are not eligible under this Category. Products intended for cove lighting or marketed as “decorative” or “architectural” are eligible under this Category. An example is shown in **Figure 27**.

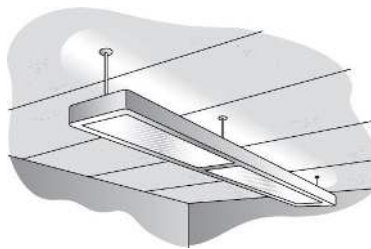

Figure 27: Example of an eligible linear ambient luminaire with indirect component. (Image credit: Focus on Energy®)

28.2.11 High Bay Luminaires (Commercial and Industrial)

A pendant, recessed, or surface-mounted luminaire specific to indoor high-ceiling spaces (intended for ceilings 25 feet or higher). An example is shown in **Figure 28**.

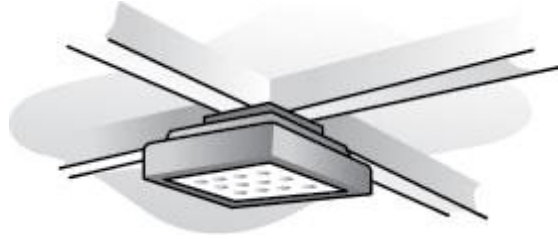

Figure 28: Example of an eligible high-bay luminaire. (Image credit: Focus on Energy®)

28.2.12 High Bay Aisle Luminaires (Commercial and Industrial)

A pendant or surface-mounted luminaire specific to indoor high-ceiling spaces (intended for ceilings 25 feet or higher), in locations that require lighting of aisles. An example is shown in **Figure 29**.

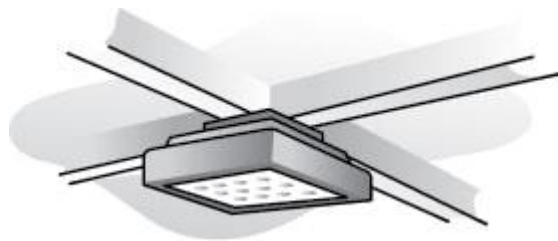

Figure 29: Example of an eligible high-bay aisle Luminaire. (Image credit: Focus on Energy®)

28.2.13 Hazardous Environment High-Bay Luminaires

A suspended, recessed, or surface-mounted luminaire specific to indoor high-ceiling spaces (intended for ceilings 25 feet or higher) that are to be used as hazardous location areas as defined in [UL 844](#) (e.g., extreme temperatures, vibrations, volatile substances).



Figure 30: Example of a Hazardous Environment High-Bay Luminaire

28.2.14 Indirect High-Bay Luminaires

A suspended luminaire specific to indoor, high-ceiling spaces (intended for ceilings 25 feet or higher) where the luminaire is designed to point at the ceiling or wall but not the floor.



Figure 31: Example of an Indirect High-Bay Luminaire

28.2.15 Low-Bay Luminaires (Commercial and Industrial)

A pendant, recessed, or surface-mounted luminaire specific to indoor spaces (intended for spaces with ceilings lower than 25 feet). An example is shown in **Figure 32**.

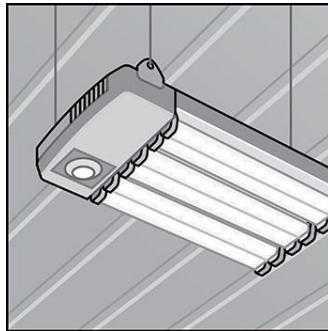

Figure 32: Example of an eligible low-bay luminaire. (Image credit: Efficiency Vermont)

28.2.16 Hazardous Environment Low-Bay Luminaires

A suspended, recessed, or surface-mounted luminaire specific to indoor spaces (intended for spaces with ceilings lower than 25 feet) that are to be used as hazardous location areas as defined in [UL 844](#) (e.g., extreme temperatures, vibrations, volatile substances).

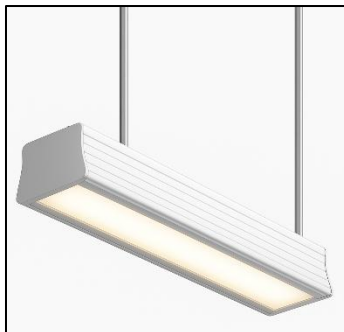

Figure 33: Example of a Hazardous Environment Low-Bay Luminaire

28.3 Outdoor Retrofit Kits

28.3.1 Retrofit Kits for Outdoor Pole/Arm-Mounted Area and Roadway Luminaires

An integrated-style kit that replaces all reflectors and optical systems of an existing luminaire. Does not include screw-in “lamps” intended as HID replacements. An example is shown in **Figure 34**.



Figure 34: Example of an outdoor pole/arm-mounted area and roadway luminaire. (Image credit: Focus on Energy®)

28.3.2 Retrofit Kits for Outdoor Pole/Arm-Mounted Decorative Luminaires

An integrated-style kit that replaces all reflectors and optical systems of an existing luminaire. Does not include screw-in “lamps” intended as HID replacements. An example is shown in **Figure 35**.



Figure 35: Example of an outdoor pole/arm-mounted decorative luminaire (Image credit: Efficiency Vermont)

28.3.3 Retrofit Kits for Large Outdoor Pole/Arm-Mounted Area and Roadway Luminaires

An integrated-style kit that replaces all reflectors and optical systems of an existing luminaire. Does not include screw-in “lamps” intended as HID replacements. An example is shown in **Figure 36**.



Figure 36: Example of an outdoor pole/arm-mounted area and roadway luminaire. (Image credit: Focus on Energy®)

28.3.4 Retrofit Kits for Outdoor Zero-Uplight Wall-Mounted Area Luminaires

An integrated-style kit that replaces all reflectors and optical systems of an existing luminaire. Does not include screw-in “lamps” intended as HID replacements. An example is shown in **Figure 37**.

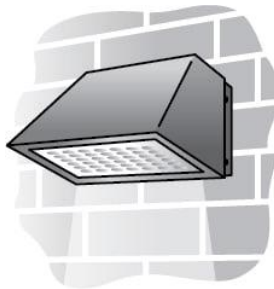

Figure 37: Example of an eligible outdoor zero-uplight wall-mounted luminaires. (Image credit: Focus on Energy®)

28.3.5 Retrofit Kits for Parking Garage Luminaires

An integrated-style kit that replaces all reflectors and optical systems of an existing luminaire. Does not include screw-in “lamps” intended as HID replacements. An example is shown in **Figure 38**.

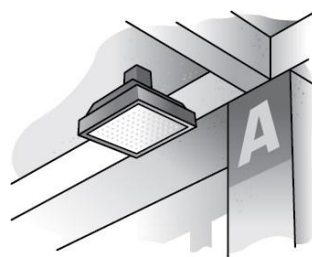

Figure 38: Example of a parking garage luminaires. (Image credit: Focus on Energy®)

28.3.6 Retrofit Kits for Fuel Pump Canopy Luminaires

An integrated-style kit that replaces all reflectors and optical systems of an existing luminaire. Does not include screw-in “lamps” intended as HID replacements. An example is shown in **Figure 39**.

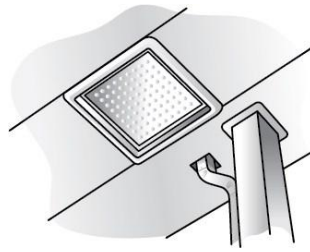

Figure 39: Example of a fuel pump canopy luminaires. (Image credit: Focus on Energy®)

28.4 Indoor Retrofit Kit

28.4.1 Linear Retrofit Kits for 2x2 Luminaires

A tube-shaped or strip-style retrofit kit for troffers. Products in this category do not replace the optical system of the existing luminaire and leave the basic form of the existing luminaire intact or exposed. These retrofit kits may not employ existing lamp holders or “pin” bases.

28.4.2 Integrated Retrofit Kits for 2x2 Luminaires

Retrofit system which replaces the entire optical system of the existing luminaire and fully integrates a replacement light source, optics, and reflective panel, where the panel connects with the luminaire housing front along two or more opposing sides and when installed, fully conceals the interior of the existing housing. These retrofit kits may not employ existing lamp holders or “pin” bases, and retrofit kits that have exposed LEDs, tube-style lenses, or bar-style components are not eligible.

28.4.3 Linear Retrofit Kits for 1x4 Luminaires

A tube-shaped or strip-style retrofit kit for troffers. Products in this category do not replace the optical systems of the existing luminaire and leave the basic form of the existing luminaire intact or exposed. These retrofit kits may not employ existing lamp holders or “pin” bases.

28.4.4 Integrated Retrofit Kits for 1x4 Luminaires

A retrofit system that replaces the entire optical system of the existing luminaire and fully integrates a replacement light source, optics, and reflective panel. The panel connects with the luminaire housing front along two or more opposing sides and when installed, fully conceals the interior of the existing housing. These retrofit kits may not employ existing lamp holders or “pin” bases, and retrofit kits that have exposed LEDs, tube style lenses, or bar-style components are not eligible.

28.4.5 Linear Retrofit Kits for 2x4 Luminaires

A tube-shaped or strip-style retrofit kit for troffers. Products in this category do not replace the optical system of the existing luminaire and leave the basic form of the existing luminaire intact or exposed. These retrofit kits may not employ existing lamp holders or “pin” bases.

28.4.6 Integrated Retrofit Kits for 2x4 Luminaires

A retrofit system that replaces the entire optical system of the existing luminaire and fully integrates a replacement light source, optics, and reflective panel, where the panel connects with the luminaire housing front along two or more opposing sides, and when installed, fully conceals the interior of the existing housing. These retrofit kits may not employ existing lamp holders or “pin” bases, and retrofit kits that have exposed LEDs, tube-style lenses, or bar-style components are not eligible.

28.4.7 Retrofit Kits for Direct Linear Ambient Luminaires

Retrofit kits for “strip” luminaires and other types of linear ambient luminaires. Do not employ existing lamp holders or “pin” bases. Examples shown in **Figure 40** and **Figure 41**.

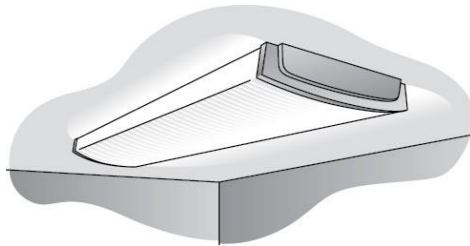

Figure 40: Example of eligible Retrofit Kit for Direct Linear Ambient Luminaires. Image credit Focus on Energy

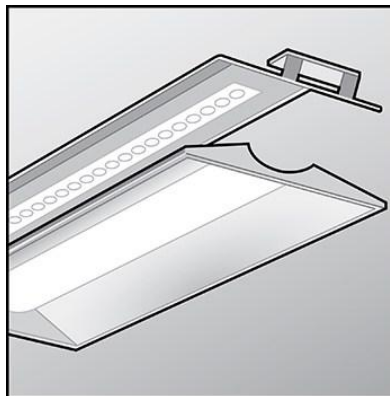

Figure 41: Example of Non-Eligible Retrofit Kit for Direct Linear Ambient Luminaires. Image credit Efficiency Vermont

28.4.8 Retrofit Kits for High-Bay Luminaires

Integrated-style kits that replace all reflectors and optical systems of existing luminaires. Not screw-in “lamps” intended as HID replacements. Example shown in **Figure 42**.

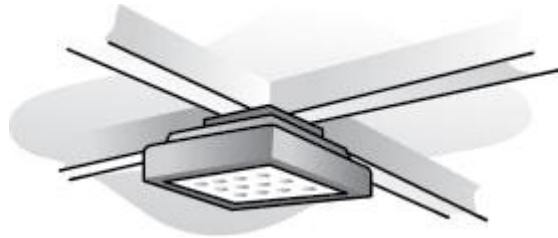

Figure 42: Example of eligible Retrofit Kit for High-Bay Luminaires. Image credit Focus on Energy.

28.4.9 Retrofit Kits for Low-Bay Luminaires

Integrated-style kits that replace all reflectors and optical systems of existing luminaires. Not screw-in “lamps” intended as HID replacements. For examples, click the blue info button.

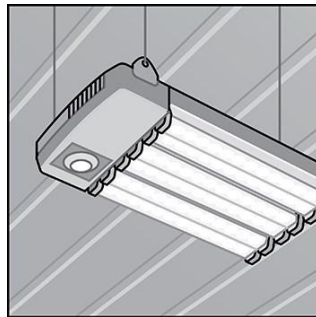

Figure 43: Example of eligible Retrofit Kit for Low-Bay Luminaires. Image credit Efficiency Vermont.

28.5 Solar Powered Outdoor Luminaires

The additional reporting requirements for Solar Powered Outdoor Luminaire PUDs are not reflected in their definitions. As a result, these PUDs adopt the same definitions as the analogous **Outdoor** products.

28.6 Linear Replacement Lamps

28.6.1 2’ T8 Lamps

An LED lamp intended to replace a two-foot T8 or T12 fluorescent lamp. These LED lamps shall be 24 inches long and employ a G13 base. Marketing material shall indicate that they are intended to replace T8 fluorescent lamps of the same length. Products of different lengths and bases are not eligible under this general application. Products intended to operate on magnetic ballasts are not eligible.

28.6.2 3' T8 Lamps

An LED lamp intended to replace a three-foot T8 or T12 fluorescent lamp. These LED lamps shall be 36 inches long and employ a G13 base. Marketing material shall indicate that they are intended to replace T8 fluorescent lamps of the same length. Products of different lengths and bases are not eligible under this general application. Products intended to operate on magnetic ballasts are not eligible.

28.6.3 4' T8 Lamps

An LED lamp intended to replace a four-foot T8 or T12 fluorescent lamp. These LED lamps shall be 48 inches long and employ a G13 base. Marketing material shall indicate that they are intended to replace T8 fluorescent lamps of the same length. Products of different lengths and bases are not eligible under this general application. Products intended to operate on magnetic ballasts are not eligible.

28.6.4 4' T5 Lamps

An LED lamp intended to replace a T5 fluorescent lamp (note, *not* T5 High Output or T5HO). These LED lamps shall be 46 inches long and employ a G5 base. Marketing material shall indicate that they are intended to replace T5 fluorescent lamps of the same length. Products of different lengths, bases, or marketed as intended to replace other types of fluorescent lamps are not eligible under this general application.

28.6.5 4' T5HO Lamps

An LED lamp intended to replace a T5HO fluorescent lamp. These LED lamps shall be 46 inches long and employ a G5 base. Marketing material shall indicate that they are intended to replace T5HO fluorescent lamps of the same length. Products of different lengths, bases, or marketed as intended to replace other types of fluorescent lamps are not eligible under this general application.

28.6.6 8' T8 Lamps

An LED lamp intended to replace an eight-foot T8 or T12 fluorescent lamp. These LED lamps shall be 96 inches long and employ an FA8 base. Marketing material shall indicate that they are intended to replace T8 fluorescent lamps of the same length. Products of different lengths and bases are not eligible under this general application. Products intended to operate on magnetic ballasts are not eligible.

28.6.7 U-Bend Replacement Lamps

LED lamps intended to replace U-bend T8 or T12 fluorescent lamps. These LED lamps shall employ a G13 base. Marketing material shall indicate that they are intended to replace T8 or T12 fluorescent lamps of the same shape. Products of different bases are not eligible. An example is shown in **Figure 44**.

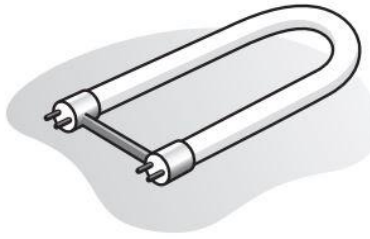

Figure 44: Example of an eligible U-bend replacement lamp. (Image credit: Focus on Energy®)

28.6.8 Replacement Lamps ("Plug and Play") (UL Type A)

A two-foot, three-foot, four-foot, eight-foot, or U-bend LED “tube” designed to replace a two-foot, three-foot, four-foot, eight-foot, or U-bend fluorescent lamp, respectively. Products in this primary use designation employ lamp holders to connect to the luminaire being retrofitted and are designed to be “plug and play” replacements for fluorescent lamps. That is, products in this category operate utilizing an existing fluorescent ballast, and do not require mechanical or electrical changes to the luminaire. It is important to note that due to testing considerations, at this time only products that operate utilizing specific ballast types are eligible. Replacement lamps that are designed to operate utilizing magnetic ballasts or other types of electronic ballasts not specified are not eligible at this time. In addition, products that are meant to replace T12 lamps are not eligible under Type-A Primary Use Designations. (Please note that reference to UL Type A is derived from UL 1993, 4th edition, 2012-12-04, Section SA6.13.1.)

28.6.9 Internal Driver/Line Voltage (UL Type B) Lamps

A two-foot, three-foot, four-foot, eight-foot, or U-bend LED “tube” designed to replace a two-foot, three-foot, four-foot, eight-foot, or U-bend fluorescent lamp, respectively. Products in this category employ lamp holders to connect to the luminaire being retrofitted, but do not operate utilizing the existing fluorescent ballast. These products require rewiring of the existing luminaire to bypass the ballast and send line voltage directly to the lamp holders. (Please note that reference to UL Type B is derived from UL 1993, 4th edition, 2012-12-04, Section SA6.13.1.)

Important: Internally driven lamps that can operate utilizing a fluorescent ballast or utilizing line-voltage will be denoted as “Dual Mode” on the QPL. Products must be tested under worst-case operating conditions.

28.6.10 1-Lamp External Driver (UL Type C) Lamps

A two-foot, three-foot, four-foot, eight-foot, or U-bend LED “tube” designed to replace a two-foot, three-foot, four-foot, eight-foot, or U-bend fluorescent lamp, respectively. Products in this category employ lamp holders to connect to the luminaire being retrofitted, do not operate utilizing the existing fluorescent ballast, and require rewiring of the existing luminaire to replace the ballast with an external driver. The lamp holders are then wired to receive only the low-voltage electricity that is supplied by



that external driver. (Please note that reference to UL Type C is derived from UL 1993, 4th edition, 2012-12-04, Section SA6.13.1.)

28.6.11 2-lamp External Driver (UL Type C) Lamps

A two-foot, three-foot, four-foot, eight-foot, or U-bend LED “tube” designed to replace a two-foot, three-foot, four-foot, eight-foot, or U-bend fluorescent lamp, respectively. Products in this category employ lamp holders to connect to the luminaire being retrofitted, do not operate utilizing the existing fluorescent ballast, and require rewiring of the existing luminaire to replace the ballast with an external driver. The lamp holders are then wired to receive only the low-voltage electricity that is supplied by that external driver. (Please note that reference to UL Type C is derived from UL 1993, 4th edition, 2012-12-04, Section SA6.13.1.)

28.6.12 3-lamp External Driver (UL Type C) Lamps

A two-foot, three-foot, four-foot, eight-foot, or U-bend LED “tube” designed to replace a two-foot, three-foot, four-foot, eight-foot, or U-bend fluorescent lamp, respectively. Products in this category employ lamp holders to connect to the luminaire being retrofitted, do not operate utilizing the existing fluorescent ballast, and require rewiring of the existing luminaire to replace the ballast with an external driver. The lamp holders are then wired to receive only the low-voltage electricity that is supplied by that external driver. (Please note that reference to UL Type C is derived from UL 1993, 4th edition, 2012-12-04, Section SA6.13.1.)

28.6.13 4-lamp External Driver (UL Type C) Lamps

A two-foot, three-foot, four-foot, eight-foot, or U-bend LED “tube” designed to replace a two-foot, three-foot, four-foot, eight-foot, or U-bend fluorescent lamp, respectively. Products in this category employ lamp holders to connect to the luminaire being retrofitted, do not operate utilizing the existing fluorescent ballast, and require rewiring of the existing luminaire to replace the ballast with an external driver. The lamp holders are then wired to receive only the low-voltage electricity that is supplied by that external driver. (Please note that reference to UL Type C is derived from UL 1993, 4th edition, 2012-12-04, Section SA6.13.1.)

28.6.14 6-lamp External Driver (UL Type C) Lamps

A two-foot, three-foot, four-foot, eight-foot, or U-bend LED “tube” designed to replace a two-foot, three-foot, four-foot, eight-foot, or U-bend fluorescent lamp, respectively. Products in this category employ lamp holders to connect to the luminaire being retrofitted, do not operate utilizing the existing fluorescent ballast, and require rewiring of the existing luminaire to replace the ballast with an external driver. The lamp holders are then wired to receive only the low-voltage electricity that is supplied by that external driver. (Please note that reference to UL Type C is derived from UL 1993, 4th edition, 2012-12-04, Section SA6.13.1.)

28.6.15 Dual Mode Internal Driver (UL Type A or B) Lamps

A two-foot, three-foot, four-foot, eight-foot, or U-bend LED “tube” designed to replace a two-foot, three-foot, four-foot, eight-foot, or U-bend fluorescent lamp, respectively. Products in this category operate utilizing the existing fluorescent ballast and also have the ability to operate utilizing line voltage if the luminaire is rewired to bypass the ballast. These products connect to the luminaire using standard pin-base connections to the lamp holders. It is important to note that due to testing considerations, at this time only products that operate utilizing specific ballast types are eligible. Replacement lamps that are designed to operate utilizing magnetic ballasts or other types of electronic ballasts not specified are not eligible at this time. In addition, products that are meant to replace T12 lamps are not eligible under Dual-Mode Primary Use Designations. (Please note that reference to UL Types A and B is derived from UL 1993, 4th edition, 2012-12-04, Section SA6.13.1.)

28.6.16 Internal Driver/Line Voltage Lamp-Style Retrofit Kits (UL Type B)

A retrofit kit designed to replace a U-bend fluorescent lamp, respectively. These products require rewiring of the existing luminaire to bypass the ballast and send line voltage directly to the lamp holders. (Please note that reference to UL Type B is derived from UL 1993, 4th edition, 2012-12-04, Section SA6.13.1.)

Important: Internally driven lamps that can operate utilizing a fluorescent ballast or utilizing line-voltage will be denoted as “Dual Mode” on the QPL. Products must be tested under worst-case operating condition.

28.7 Mogul Screw-Base (E39/E40) Replacements for HID Lamps

The following images serve as examples of eligible Mogul Screw-Base (E39/E40) Replacements for HID Lamps.



Figure 45: Examples of eligible Mogul Screw-Base (E39/E40) Replacements for HID Lamps

28.7.1 Replacement Lamps for Outdoor Pole/Arm-Mounted Area and Roadway Luminaires (UL Type B)

An LED replacement lamp for HID lamps which requires the existing HID ballast to be bypassed and the lamp holder to be wired with line voltage; used in outdoor pole- or arm-mounted area and roadway



luminaires. Only mogul-base (E39 and E40) products are eligible. Lamps are only considered qualified in the end uses they are listed in.

28.7.2 Replacement Lamps for Outdoor Pole/Arm-Mounted Decorative Luminaires (UL Type B)

An LED replacement lamp for HID lamps that requires the existing HID ballast to be bypassed and the lamp holder to be wired with line voltage; used in outdoor decorative luminaires. Only mogul-base (E39 and E40) products are eligible. Lamps are only considered qualified in the end uses they are listed in.

28.7.3 Replacement Lamps for Outdoor Zero-Uplight Wall-Mounted Area Luminaires (UL Type B)

An LED replacement lamp for HID lamps that requires the existing HID ballast to be bypassed and the lamp holder to be wired with line voltage; used in outdoor wall-mounted area luminaires. Only mogul-base (E39 and E40) products are eligible. Lamps are only considered qualified in the end uses they are listed in.

28.7.4 Replacement Lamps for Parking Garage Luminaires (UL Type B)

An LED replacement lamps for HID lamps that require the existing HID ballast to be bypassed and the lamp holder to be wired with line voltage, used in parking garage luminaires. Only mogul-base (E39 and E40) products are eligible. Lamps are only considered qualified in the end uses they are listed in

28.7.5 Replacement Lamps for Fuel Pump Canopy Luminaires (UL Type B)

LED replacement lamp for HID lamps that requires the existing HID ballast to be bypassed and the lamp holder to be wired with line voltage; used in fuel pump canopy luminaires. Only mogul-base (E39 and E40) products are eligible. Lamps are only considered qualified in the end uses they are listed in

28.7.6 Replacement Lamps for Outdoor Pole/Arm-Mounted Area and Roadway Luminaires (UL Type C)

An LED replacement lamp for HID lamps that requires the existing HID ballast to be replaced with an external LED driver (the lamp holder is not wired with line voltage), used in outdoor pole- and arm-mounted area and roadway luminaires. Only mogul screw-base (E39 and E40) products are eligible. Lamps are only considered qualified in the end uses they are listed in.

28.7.7 Replacement Lamps for Outdoor Pole/Arm-Mounted Decorative Luminaires (UL Type C)

An LED replacement lamp for HID lamps that requires the existing HID ballast to be replaced with an external LED driver (the lamp holder is not wired with line voltage); used in outdoor wall-mounted area



luminaires. Only mogul screw-base (E39 and E40) products are eligible. Lamps are only considered qualified in the end uses they are listed in.

28.7.8 Replacement Lamps for Outdoor Zero-Uplight Wall-Mounted Area Luminaires (UL Type C)

An LED replacement lamp for HID lamps that requires the existing HID ballast to be replaced with an external LED driver (the lamp holder is not wired with line voltage); used in outdoor decorative luminaires. Only mogul screw-base (E39 and E40) products are eligible. Lamps are only considered qualified in the end uses they are listed in.

28.7.9 Replacement Lamps for Parking Garage Luminaires (UL Type C)

LED replacement lamps for HID lamps that require the existing HID ballast to be replaced with an external LED driver (the lamp holder is not wired with line voltage), used in parking garage luminaires. Only mogul screw-base (E39 and E40) products are eligible. Lamps are only considered qualified in the end uses they are listed in.

28.7.10 Replacement Lamps for Fuel Pump Canopy Luminaires (UL Type C)

An LED replacement lamp for HID lamps that requires the existing HID ballast to be replaced with an external LED driver (the lamp holder is not wired with line voltage); used in fuel pump canopy luminaires. Only mogul screw-base (E39 and E40) products are eligible. Lamps are only considered qualified in the end uses they are listed in.

28.7.11 Replacement Lamps for High-Bay Luminaires (UL Type B)

An LED replacement lamp for HID lamps that requires the existing HID ballast to be bypassed and the lamp holder to be wired with line voltage; used in high-bay luminaires. Only mogul screw-base (E39 and E40) products are eligible. Lamps are only considered qualified in the end uses they are listed in.

28.7.12 Replacement Lamps for High-Bay Luminaires (UL Type C)

An LED replacement lamp for HID lamps that requires the existing HID ballast to be replaced with an external LED driver (the lamp holder is not wired with line voltage); used in high-bay luminaires. Only mogul screw-base (E39 and E40) products are eligible. Lamps are only considered qualified in the end uses they are listed in.

28.7.13 Replacement Lamps for Low-Bay Luminaires (UL Type B)

An LED replacement lamp for HID lamps that requires the existing HID ballast to be bypassed and the lamp holder to be wired with line voltage; used in low-bay luminaires. Only mogul screw-base (E39 and E40) products are eligible. Lamps are only considered qualified in the end uses they are listed in.

28.7.14 Replacement Lamps for Low-Bay Luminaires (UL Type C)

An LED replacement lamp for HID lamps that requires the existing HID ballast to be replaced with an external LED driver (the lamp holder is not wired with line voltage); used in low-bay luminaires. Only mogul screw-base (E39 and E40) products are eligible. Lamps are only considered qualified in the end uses they are listed in.

28.7.15 Omnidirectional/Directional Replacement Lamps (UL Type B)

An LED replacement lamp for HID lamps that requires the existing HID ballast to be bypassed and the lamp holder to be wired with line voltage. Lamps can look like “corn cobs” or have an elliptical, reflector, or paddle shape. Some of these lamps have a field adjustable light distribution. Only mogul screw-base (E39 and E40) products are eligible.

28.8 Medium Screw-Base (E26, E27) Replacement for HID Lamps

The following images serve as examples of eligible Medium Screw-Base (E26/E27) Replacements for HID Lamps.



Figure 46: Examples of eligible Medium Screw-Base (E26/E27) Replacements for HID Lamps

28.8.1 Omnidirectional/Directional Replacement Lamps (UL Type B)

An LED replacement lamp for HID lamps that requires the existing HID ballast to be bypassed and the lamp holder to be wired with line voltage. Lamps can look like “corn cobs” or have an elliptical, reflector, or paddle shape. Some of these lamps have a field adjustable light distribution. Only medium screw-base (E26 and E27) products are eligible.

28.9 Four Pin-Base Replacement Lamp for CFLs

A G24q- or GX24q-base LED lamp, or a 2G11 base lamp greater than or equal to twenty inches, designed to replace compact fluorescent lamps (CFLs). At this time, G24q/GX24q and 2G11 UL Type A lamps (designed to operate utilizing the existing CFL ballast), and 2G11 UL Type B (designed to operate utilizing direct line voltage), 2G11 UL Type C (designed to operate utilizing a non-integral driver), and 2G11 UL dual mode (designed to operate utilizing the existing CFL ballast or direct line voltage) are all eligible. Dual mode lamps, G24q or GX24q UL Type B lamps and UL Type C lamps, as well as products with other



bases (including 2-pin products), are not eligible. At this time, only products that can operate utilizing specific ballast types are eligible. Replacement lamps designed to operate utilizing magnetic ballasts, or other types of electronic ballasts not specified, are not eligible at this time.



29 Appendix B: Referenced Standards

Standard # or Document Name	Title and URL
ANSI C136.10-2023	Roadway and Area Lighting Equipment - Locking-Type Photocontrol Devices and Mating Receptacles - Physical and Electrical Interchangeability and Testing https://webstore.ansi.org/standards/nema/ansic136102023
ANSI C136.41-2025	Roadway And Area Lighting Equipment–Dimming Control Between An External Locking Type Photocontrol And Ballast Or Driver https://webstore.ansi.org/Search/Find?in=1&st=c136.41
ANSI C137.4-2019	Lighting Systems - Digital Interface With Auxiliary Power https://webstore.ansi.org/Standards/NEMA/ANSIC1372019-2392109
ANSI C78.377-2024	Electric Lamps - Specifications For The Chromaticity Of Solid-State Lighting Products https://webstore.ansi.org/Standards/NEMA/ANSIC783772017
ANSI/ASHRAE/IES 90.1-2022	Energy Standard for Buildings Except Low-Rise Residential Building https://www.ashrae.org/technical-resources/bookstore/standard-90-1 https://store.ies.org/product/ansi-ashrae-ies-standard-90-1-2022-energy-standard-for-buildings-except-low-rise-residential-buildings-i-p-edition/?v=0b3b97fa6688
ANSI/IES LM-63-19 and ANSI/IES LM-63-02 R2008	Lighting Measurement: APPROVED METHOD: IES STANDARD FILE FORMAT FOR THE ELECTRONIC TRANSFER OF PHOTOMETRIC DATA AND RELATED INFORMATION https://store.ies.org/product/lm-63-19-approved-method-ies-standard-file-format-for-the-electronic-transfer-of-photometric-data-and-related-information/
ANSI/IES LM-79-24 and ANSI/IES LM-79-19	Approved Method: Optical and Electrical Measurements of Solid-State Lighting Products https://store.ies.org/product/optical-and-electrical-measurements-of-solid-state-lighting-products/?v=0b3b97fa6688
ANSI/IES LM-80-21 and ANSI/IES LM-80-20 and ANSI/IES LM-80-15 and IESNA LM-80-08	Approved Method: Measuring Maintenance of Light Output Characteristics of Solid-State Light Sources https://store.ies.org/product/lm-80-21-measuring-maintenance-of-light-output-characteristics-of-solid-state-light-sources/?v=0b3b97fa6688
ANSI/IES LM-84-20	Approved Method: Measuring Optical Radiation Maintenance of LED Lamps, Light Engines, and Luminaires https://store.ies.org/product/lm-84-20-approved-method-measuring-optical-radiation-maintenance-of-led-lamps-light-engines-and-luminaires/?v=0b3b97fa6688



Standard # or Document Name	Title and URL
ANSI/IES LM-98-24	Approved Method: Measuring In-Situ Temperature of Solid-State Lighting Components in Lamps and Luminaires https://store.ies.org/product/approved-method-measuring-in-situ-temperature-of-solid-state-lighting-components-in-lamps-and-luminaires/?v=0b3b97fa6688
ANSI/IES LS-1-22	https://ies.org/standards/definitions/
ANSI/IES TM-15-20	Technical Memorandum: Luminaire Classification System for Outdoor Luminaires https://store.ies.org/product/tm-15-20-technical-memorandum-luminaire-classification-system-for-outdoor-luminaires/?v=0b3b97fa6688
ANSI/IES TM-21-21, ANSI/IES TM-21-19, and IES TM-21-11	Technical Memorandum: Projecting Long-Term Luminous, Photon, and Radiant Flux Maintenance of LED Light Sources https://store.ies.org/product/tm-21-21-projecting-long-term-luminous-photon-and-radiant-flux-maintenance-of-led-light-sources/?v=0b3b97fa6688
ANSI/IES TM-27-20 and IES TM-27-14	Technical Memorandum: IES Standard Format for the Electronic Transfer of Spectral Data https://store.ies.org/product/tm-27-20-technical-memorandum-ies-standard-format-for-the-electronic-transfer-of-spectral-data/
ANSI/IES TM-28-20	Approved Method: Projecting Long-Term Luminous Flux Maintenance of LED Lamps and Luminaires https://store.ies.org/product/tm-28-20-approved-method-projecting-long-term-luminous-flux-maintenance-of-led-lamps-and-luminaires/?v=0b3b97fa6688
ANSI/IES TM-30-20	Technical Memorandum: IES Method for Evaluating Light Source Color Rendition https://store.ies.org/product/technical-memorandum-ies-method-for-evaluating-light-source-color-rendition/?v=0b3b97fa6688
ANSI/IES TM-33-23 and ANSI/IES TM-33-18	Technical Memorandum: Standard Format for the Electronic Transfer of Luminaire Optical Data https://store.ies.org/product/technical-memorandum-standard-format-for-the-electronic-transfer-of-luminaire-optical-data/?v=0b3b97fa6688
ANSI/IES TM-35-19 (R25)	Technical Memorandum: Projecting Long-Term Chromaticity Coordinate Shift of LED Packages, Arrays, and Modules https://store.ies.org/product/technical-memorandum-projecting-long-term-chromaticity-coordinate-shift-of-led-packages-arrays-and-modules/?v=0b3b97fa6688
ANSI/IES TM-41-24	Technical Memorandum: Standard Format for the Electronic Data Transfer of Light Output Maintenance Characteristics of Solid-State Light Sources https://store.ies.org/product/technical-memorandum-standard-format-for-the-electronic-data-transfer-of-light-output-maintenance-characteristics-of-solid-state-light-sources/?v=0b3b97fa6688

Standard # or Document Name	Title and URL
BACnet	BACnet – A Data Communication Protocol for Building Automation and Control Networks http://www.bacnet.org
Bluetooth protocols and Bluetooth NLC	https://www.bluetooth.com/specifications/specs/
CA Title 24	California Building Energy Efficiency Standards – Title 24 https://www.energy.ca.gov/programs-and-topics/programs/building-energy-efficiency-standards
CIE 13.3-1995	METHOD OF MEASURING AND SPECIFYING COLOUR RENDERING PROPERTIES OF LIGHT SOURCES http://cie.co.at/publications/method-measuring-and-specifying-colour-rendering-properties-light-sources
CIE 190:2010	https://cie.co.at/publications/calculation-and-presentation-united-glare-rating-tables-indoor-lighting-luminaires
D4i ANSI C137.4-2025	D4i is the DALI standard for intelligent, IoT-ready luminaires. Aligned with ANSI C137.4 Lighting Systems – Interoperability of LED drivers with digital addressable lighting interface and other connected devices https://www.dali-alliance.org/d4i/ https://webstore.ansi.org/standards/nema/ansic1372025-2587849
DALI	DALI is short for Digital Addressable Lighting Interface. It is an industry-standardized protocol, and is specified in the multi-part international standard IEC 62386 https://www.dali-alliance.org/ https://webstore.iec.ch/en/iec-search/result?q=62386&p=1&f=eyJkYXRlUmFuZ2VzIjp7fSwidGVybmVMiOnt9LCJ2YWxpZE9ubHkiOnRydWUsluB1YmXpY2F0aW9uSWRzljpuZWxsLCJzaG93VHJmljpmYWxzZSwiZGlzcGxheU1vZGUiOiJsaXN0In0=
DALI-2	Certification program based on parts of IEC 62386 and D4i https://www.dali-alliance.org/
DALI+	DALI+ devices communicate using existing DALI commands over a wireless and/or IP-based medium rather than the dedicated pair of wires used by DALI-2 and D4i. https://www.dali-alliance.org/dalipus/
DLC SSL Technical Requirements V5.1	DLC Solid State Lighting Technical Requirements V5.1 https://www.designlights.org/our-work/solid-state-lighting/technical-requirements/ssl-v5-1

Standard # or Document Name	Title and URL
DLC NLC5 Technical Requirements	DLC Networked Lighting Controls Technical Requirements Version 5 https://www.designlights.org/our-work/networked-lighting-controls/technical-requirements/nlc5/
DMX512	ANSI E1.11-2024 Entertainment Technology - USITT DMX512-A, Asynchronous Serial Digital Data Transmission Standard for Controlling Lighting Equipment and Accessories https://webstore.ansi.org/standards/esta/ansie1112024
EnOcean	EnOcean Alliance self-powered wireless communication https://www.enocean-alliance.org/ EnOcean radio standard is based on the ISO/IEC 14543-3-10/11 standard https://webstore.iec.ch/en/publication/63311
IEC 62680-1-3:2024	Universal serial bus interfaces for data and power - Part 1-3: Common components - USB Type-C® cable and connector specification https://webstore.iec.ch/en/publication/91100
IECC 2024	2024 International Energy Conservation Code (IECC) https://codes.iccsafe.org/content/IECC2024V1.2
ISO 14025:2006	ISO 14025:2006 Environmental labels and declarations — Type III environmental declarations — Principles and procedures https://www.iso.org/standard/38131.html
ISO 16484-5:2022	Building automation and control systems (BACS) Data communication protocol Used for BACnet
Esposito and Radetsky (2023)	Specifying Non-White Light Sources in Outdoor Applications to Reduce Light Pollution https://doi.org/10.1080/15502724.2022.2121285 https://designlights.org/wp-content/uploads/2023/01/2022_Esposito-Radetsky_Specifying-NWL-sources_AcceptedManuscript.pdf
KNX	The KNX standard is a smart home and building specification developed by the KNX Association https://www.knx.org/knx-en/for-professionals/index.php
Modbus	Modbus https://www.modbus.org
Power Over Ethernet	Power over Ethernet per IEEE P802.3-2022 (IEEE Standard for Ethernet) https://standards.ieee.org/ieee/802.3/10422/
TALQ	TALQ Specification Version 2.0 https://www.talg-consortium.org/2-why-talg/specification/



Standard # or Document Name	Title and URL
WiFi	IEEE 802.11-2024 https://ieeexplore.ieee.org/document/10979691
Zhaga Book 18	Smart interface between outdoor luminaires and sensing / communication modules https://www.zhagastandard.org/books/overview/smart-interface-between-outdoor-luminaires-and-sensing-communication-modules-18.html
Zhaga Book 20	Smart interface between indoor luminaires and sensing / communication modules https://www.zhagastandard.org/books/overview/smart-interface-between-indoor-luminaires-and-sensing-communication-modules-20.html
Zigbee	The Connectivity Standards Alliance develops universal open standards that enable all objects to securely connect and interact. https://csa-iot.org/all-solutions/zigbee/



Part VIII: Policy Clarifications and Updates

This section is dedicated to tracking changes to the document.

30 Policy Clarifications and Updates

After the DLC releases policies, opportunities for minor corrections and clarifications arise. Since these corrections and clarifications do not affect eligibility, the DLC will update this policy as needed. To be as transparent as possible, any changes will be tracked in the table below and on the DLC website. [Table 40](#) shows the corrections or clarifications and where they can be found in the document.

Table 40: SSL V6.0 and LUNA V2.0 Technical Requirement Corrections and Clarifications (Published as Needed)

Date Updated	Subject	Change Type	Description	Affected Page(s)
12/5/2025	Table 24: LUNA V2.0 Spectral Quality Requirements	Clarification	Added max CCT for lamps and retrofits to this section, was previously only in FACT.	78, 79
12/5/2025	Minimum Testing Requirements: LUNA Spectral Quality	Formatting	Fixed formatting to align with other cross references.	132
12/5/2025	Table 8: Primary Use Designation Technical Requirements: Light Distribution	Correction	Updated PUD AB distribution requirements to match PUD C.	26, 27
12/5/2025	Table 20: DLC Premium Efficacy Requirements	Correction	Changed incorrect PUD name “Retrofit Kits for Outdoor Wall-Mounted Area Luminaires” to “Retrofit Kits for Outdoor Zero-Uplight Wall-Mounted Area Luminaires.”	68
12/5/2025	15.6 LUNA Turtle Lighting PUD Requirements	Correction	Updated cross reference to correct table and fixed typo.	81
12/5/2025	Table 31: Testing and Reporting Requirements for Spectral Quality for Products with Amber LEDs (DLC Standard)	Correction	Section referenced LUNA products where it should have referenced amber products.	101
12/5/2025	Table 18: Efficacy Allowances	Correction	Eligible indoor products was duplicated and outdoor products missing. Added eligible outdoor products.	59
12/5/2025	How to Navigate this Document	Clarification	Changed “specialized” to “specific” and added roman numerals to Part V description	Between cover



Date Updated	Subject	Change Type	Description	Affected Page(s)
				page and ToC
12/5/2025	28.1.14 Sports Lighting Luminaires	Formatting	Moved section up one heading level	162
12/5/2025	14.2 Premium Eligibility & 14.4 Premium Requirements	Clarification	Removed “and Requirements” from heading; requirements in 14.4	65, 66
12/5/2025	Table 36: Required Testing to Demonstrate Compliance With SSL V6.0 and LUNA V2.0	Correction	Changed “Driver Lifetime (Standard and Premium)” to “Driver Lifetime (Premium only).”	125
12/5/2025	5.7 Special Controllability Considerations for Dimmable Lamps	Correction	Removed paragraph on UL Type Lamps	40
12/5/2025	Table 6: Light Output Requirements by Primary Use Designation	Correction	Table erroneously showed wall wash luminaires as outdoor products	22
12/5/2025	Table 18: Efficacy Allowances	Clarification	Merged cells in method of evaluation column for High Color Rendition and Enhanced Discomfort Glare Control rows.	59
12/5/2025	Table 39: Data Reporting Format for FACT, CCT-Tunable, and Full Color-Tunable Product Submissions	Formatting	Header row did not repeat	140
12/5/2025	18.2 Specifications for Amber LED Luminaires, Retrofit Kits, and Lamps	Correction	Removed references to narrowband and broadband SPD from amber definitions.	99, 100
12/5/2025	15.2 LUNA Eligibility and Requirements	Correction	Corrected cross referenced table from 23 to 22	72
12/5/2025	15.7.1 LM-79 Testing	Typo	Corrected SSDL to SSL	82



Date Updated	Subject	Change Type	Description	Affected Page(s)
12/5/2025	Table 8: Primary Use Designation Technical Requirements: Light Distribution	Correction	Restored maximum lumen output for the low bay PUD, which had been erroneously removed	27
12/5/2025	4.4 Interactions With Other DLC Policies: Field Adjustable Light Distribution (FALD) and Field Adjustable Light Output	Clarification, Typo	Added cross reference to light output section and removed dimming language. Added "FALO" acronym to section heading.	30, 31
12/5/2025	17.3 CCT-Tunable and Full Color-Tunable Eligibility	Formatting, clarification	Removed erroneous line breaks and "except chromaticity" language which confused the intent of the policy.	96
12/5/2025	22.5 Four Pin-Base Replacement Lamps for CFLs & 28.9 Four Pin-Base Replacement Lamp for CFLs	Clarification	Clarified that dual mode is ineligible under this category	179
12/5/2025	Appendix B, Table 4, 7.2 Lumen Maintenance	Correction	Removed "-21" throughout document and added "LM-80-08" to list of referenced standards	18 – 19, 52, 185 - 187
12/5/2025	Table 10: Controls Ready Receptacle Types	Clarification	State that products without a receptacle are not controls ready	35
12/5/2025	Table 1, Appendix A	Correction	Restored singular PUD names to plural versions, restored "Commercial and Industrial" to High-Bay and Low-Bay PUDs	8, 160 - 184
1/22/2026	27.3: IES TM-21-11, ANSI/IES TM-21-19, ANSI/IES TM-21-21, and the ANSI/IES TM-21 Calculator, and Appendix B: Referenced Standards	Correction	Added all accepted versions of TM-21	155 – 156, 184
1/22/2026	Table 8: Primary Use Designation Technical Requirements: Light Distribution	Correction	Updated PUD AS to match the distribution requirements of PUD C	27



Date Updated	Subject	Change Type	Description	Affected Page(s)
1/22/2026	16.2 Field Adjustable Color Temperature (FACT) & 17.3 CCT-Tunable and Full Color-Tunable Eligibility	Clarification	Added language to make it clear that CCT-Tunable products must meet 7-step and 4-step quadrangle requirements for Standard and Premium respectively and that FACT and Full color tunable products are required to maintain constant lumen output across CCTs	88, 97
1/22/2026	Table 2: DLC Standard Efficacy Requirements for Luminaires and Retrofit Kits Within Standardized CCT Quadrangles (1800 K to 6500 K as Applicable*)	Clarification	Clarified that outdoor specialty products must meet the minimum outdoor efficacy, 115 lm/W	16
1/22/2026	BUG ratings for lamps & retrofit kits	Clarification	Clarified that lamps do not need to meet BUG rating requirements, but retrofits do	25, 30 – 31, 126, - 127, 131, 155
1/22/2026	Table 8: Primary Use Designation Technical Requirements: Light Distribution	Clarification, typo	Removed unnecessary zeros after PUD Q requirements	27
1/22/2026	15.4 LUNA Spectral Quality Requirements	Formatting	First sentence was formatted as a heading with the number 15.4.1. All subheadings in 15.4 moved down one number as a result.	78 - 80
1/22/2026	30 Policy Clarifications and Updates	Clarification	Added a section number to this section to correct the issue of the header pointing to Appendix B	189 - 192
1/22/2026	27.4 IES LM-80 Version	Clarification	Added this section to explicitly state the versions of LM-80 accepted	156
1/22/2026	18.2 Specifications for Amber LED Luminaires, Retrofit Kits, and Lamps	Correction	Definitions for de-amber and pc-amber updated, no change to requirements	100 - 101
1/22/2026	Table 11	Addition	Added Dip Switch or Dial to the list on accepted Integral Controller or Sensor Type	38
1/22/2026	Table 11	Addition	Added Z10 to Top or Side Controls Receptacle Type and Bottom or Side Controls Receptacle Type	37 - 38
1/22/2026	24.2.2.3 Interactions With Other DLC	Clarification	Removed “CCT-Tunable” from CCT-Tunable and Full Color-Tunable products are not required to meet the chromaticity	130



Date Updated	Subject	Change Type	Description	Affected Page(s)
	Requirements: Color-Tunable Products and Field Adjustable Light Output (FALO) Products		requirements in SSL V6.0” as the phrasing confused the meaning of the requirement.	
1/22/2026	Table 24 & Table 31	Clarification	Added a footnote to clarify rounding for percent blue	79, 103
1/22/2026	Table 15	Addition	Added a row for dip switch and dial in the wired section	46
1/22/2026	Table 10	Addition	Added Z10 as an accepted controls ready receptacle type	35
4/15/2026	Section 5.4.1	Clarification	Added language on how to differentiate twistlock receptacles	35
4/15/2026	Table 10	Clarification	Added language to align with twistlock differentiate twistlock receptacles	35
4/15/2026	Table 11	Clarification	Added language to align with twistlock differentiate twistlock receptacles in Top or Sde Controls Receptacle Type and Bottom of Side Controls Receptacle Type	38
4/15/2026	Section 5.10	Clarification	Added language to align with twistlock differentiate twistlock receptacles	49
4/15/2026	Section 5.4.1	Addition	Opened up eligibility for products with both a 3-pin twistlock receptacle and another integral sensor or controller	35
4/15/2026	Table 10	Addition	Added Pogo Pin as an acceptable receptacle type	36
4/15/2026	Table 11	Addition	Added pogo pin as an acceptable receptacle type for Top or Side Controls Receptacle Type and Bottom or Side Controls Receptacle Type	38
4/15/2026	Table 11	Addition	Added different combinations of DALI and D4i to the list of accepted Driver Type and Integral Controller or Sensor Type	36-37
4/15/2026	Table 29	Addition	Added Up/Down/All, Left/Right/All, and Other as acceptable terms for Field Adjustable Distribution Metric	92
4/15/2026	16.6	Addition	Added subsections to differentiate QPL listing information for each type of field adjustable product – 16.6.1, 16.6.2, and 16.6.3	94 - 95
4/15/2026	Table 22	Correction	Maximum U rating for PUDs C and AB erroneously listed as 1, corrected to 0.	74
4/15/2026	17.6	Removal	Removed language on FACT QPL listing as it was moved to 16.6.2.	99